

Telephone 800-500-9311  
Telephone 864-573-9200  
Fax 864-573-9299

# OEC FLUID HANDLING INC.

SUBSIDIARY OF OILMEN'S EQUIPMENT CORP.  
[www.oecfh.com](http://www.oecfh.com)

140 Cedar Springs Rd.  
P. O. Box 2807  
Spartanburg, SC 29304

■ Stocked Items 11/06/03

## PD Pumps

- ARO Ingersoll-Rand
- Blackmer Vane  
Blackmer/Abaque Peristaltic  
Blackmer "C" Eccentric Disc
- Alfa Laval-TriClover Lobe
- APV Lobe
- Tuthill Gear  
Tuthill Lobe  
MonoFlo Progressive Cavity

## Centrifugal Pumps

- Alfa Laval-TriClover Sanitary
- APV Crepaco
- Deming End Suction  
Deming Vertical Turbine
- Griswold ANSI Pumps
- MP Pump

## Specialty Pumps

Flux Drum

## Petroleum-Fuel Pumps

- Gorman-Rupp
- Dresser Wayne Corp
- Red Jacket  
Graco  
William Wilson Gasboy

## Hand Pumps

- Blackmer
- Tokhiem
- Tuthill Fill-Rite

## Storage Tanks

Stainless Steel ASME  
UL & ASME Carbon Steel  
Fiberglass Tanks  
Chem-Tainer Poly Tanks  
Assmann Poly Tanks  
Snyder Poly Tanks

## Tank Fittings & Vents

- OPW Engineered Systems  
EMCO Wheaton  
Morrison Bros  
Protectoseal

## Mechanical Seals

Utex



## Meters & Instrumentation

- Micro Motion Coriolis
- Neptune Actaris PD
- Tuthill FPP PD
- Liquid Controls PD  
Halliburton Turbine  
Rosemount  
Pressure Transmitters  
Flow Transmitters  
Temperature Transmitters  
Level Transmitters

## Sanitary Products

- Alfa Laval-TriClover Pumps
- Alfa Laval-TriClover Fittings  
Alfa Laval-TriClover Valves  
APV Pumps  
APV Valves  
APV Homogenizers  
B & A Flexible Sanitary Hose

## Liquid Level Gauges

- Protectoseal  
Pneumercator  
Moorman Bros  
Milltronics/Siemens  
Rosemount Level Transmitters

## Hose & Reels

- Goodyear Hose
- Hannay Reels  
Lawrence Composite Hose

## Filters

Filtration Group Bag Filters

## Mixers

Brawn Portable & Sanitary  
Proquip Top Entry Agitators

## Liquid Loaders & Platforms

OPW Engineered Systems  
Green Manufacturing

## Rotary Unions

Deublin

## Custom Liquid Systems

For liquid transfer, batching &  
process metering

**Performance Guaranteed**

CHARLOTTE, NC ■ SPARTANBURG, SC ■ GREENSBORO, NC

# OPERATOR'S MANUAL

# 66605X-X

INCLUDING: OPERATION, INSTALLATION & MAINTENANCE

RELEASED: 4-15-87

REVISED: 11-24-03

(REV. AL)

## 1/2" DIAPHRAGM PUMP 1:1 RATIO (NON-METALLIC)



**READ THIS MANUAL CAREFULLY BEFORE INSTALLING,  
OPERATING OR SERVICING THIS EQUIPMENT.**

It is the responsibility of the employer to place this information in the hands of the operator. Keep for future reference.

### SERVICE KITS

Refer to Model Chart to match the pump material options.  
637140-XX for fluid section repair (see page 4).  
637141 for air section repair (see page 6).

### PUMP DATA

<b>Models</b> .....	See Model Description Chart for "-XXX".
<b>Pump Type</b> .....	Non-Metallic Air Operated Double Diaphragm
<b>Material</b> .....	See Model Description Chart.
<b>Weight</b> ....	Polypropylene ..... 7.2 (3.3 kgs)
	Groundable Acetal ..... 8.8 (4.0 kgs)
	P.V.D.F. (Kynar®) ..... 9.5 (4.3 kgs)
<b>Maximum Air Inlet Pressure</b> .....	100 p.s.i.g. (6.9 bar)
<b>Maximum Material Inlet Pressure</b> .....	10 p.s.i.g. (0.69 bar)
<b>Maximum Outlet Pressure</b> .....	100 p.s.i.g. (6.9 bar)
<b>Air Consumption</b> .....	1 c.f.m. / gallon (approx.)
<b>Maximum Flow Rate</b> (Ball) .....	13 g.p.m. (49.2 l.p.m.)
	(Duckbill) .... 10 g.p.m. (37.9 l.p.m.)
<b>Maximum Particle Size</b> (Ball) .....	3/32" dia. (2.4 mm)
	(Duckbill) .... Fibers

### Maximum Temperature Limits

E.P.R. ....	-60° to 280° F (-51° to 138° C)
Groundable Acetal .....	10° to 180° F (-12° to 82° C)
Hytrel® .....	-20° to 150° F (-29° to 66° C)
Neoprene .....	0° to 200° F (-18° to 93° C)
Nitrile .....	10° to 180° F (-12° to 82° C)
Polypropylene .....	35° to 150° F (2° to 66° C)
Polyurethane .....	10° to 150° F (-12° to 66° C)
P.V.D.F. (Kynar) .....	10° to 200° F (-12° to 93° C)
Santoprene® .....	-40° to 225° F (-40° to 107° C)
T.F.E. (Teflon®) .....	40° to 225° F (4° to 107° C)
Viton® .....	-40° to 350° F (-40° to 177° C)

**Groundable** ..... 666056-X and 66605H-X models only

**Dimensional Data** ..... see page 8

**Noise Level @ 70 p.s.i., 60 c.p.m.** ..... 71.1 db(A)

\* The pump sound pressure levels published here have been updated to an Equivalent Continuous Sound Level (L<sub>Aeq</sub>) to meet the intent of ANSI S1.13-1971, CAGI-PNEU-ROP S5.1 using four microphone locations.

**NOTICE: All possible options are shown in the chart however certain combinations may not be recommended, consult a representative or the factory if you have questions concerning availability.**

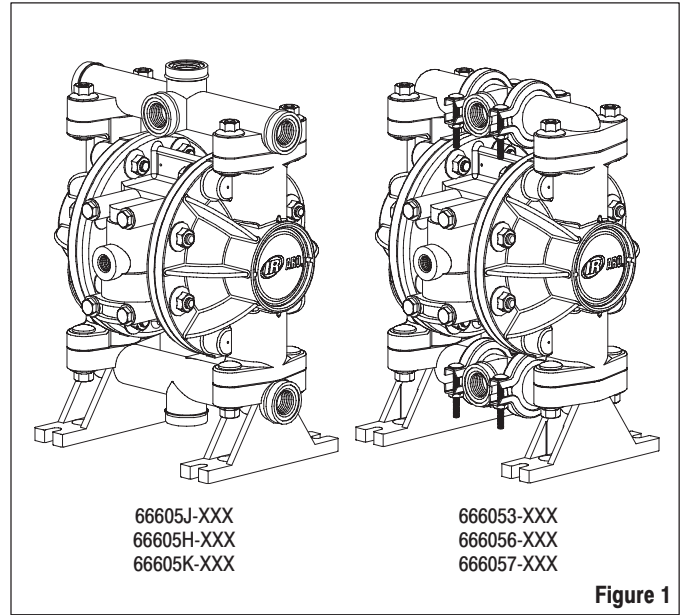

Figure 1

### MODEL DESCRIPTION CHART

		66605 X - X X X		
<b>FLUID CAPS &amp; MANIFOLD MATERIAL</b>				
	3 - Piece Manifold	Single Piece Manifold		
3 - Polypropylene	J - Polypropylene			
6 - Groundable Acetal	H - Groundable Acetal			
7 - Pure Kynar	K - Pure Kynar			
<b>SEAT MATERIAL</b>				
0 - (Duck Bill)	4 - P.V.D.F. (Kynar)			
2 - Stainless Steel	6 - Acetal			
3 - Polypropylene				
<b>BALL MATERIAL</b>				
	(*) Duckbill models			
1 - Neoprene	8 - Polyurethane			
2 - Nitrile	A - Stainless Steel			
3 - Viton	C - Neoprene (*)			
4 - T.F.E. (Teflon)	D - Nitrile (*)			
5 - E.P.R.	E - Santoprene			
<b>DIAPHRAGM MATERIAL</b>				
1 - Neoprene	5 - E.P.R.			
2 - Nitrile	8 - Polyurethane			
3 - Viton	9 - Hytrel			
4 - T.F.E. (Teflon) / Santoprene	B - Santoprene			
<b>FLUID SECTION SERVICE KIT SELECTION</b>				
EXAMPLE: MODEL # 666053-321		66605X - X X X		
Fluid Section Service Kit # 637140-21		637140 - [X][X]		
		Ball [ ]	Diaphragm [ ]	



## OPERATING AND SAFETY PRECAUTIONS

READ, UNDERSTAND AND FOLLOW THIS INFORMATION TO AVOID INJURY AND PROPERTY DAMAGE.



**⚠ WARNING** EXCESSIVE AIR PRESSURE. Can cause personal injury, pump damage or property damage.

- Do not exceed the maximum inlet air pressure as stated on the pump model plate.
- Be sure material hoses and other components are able to withstand fluid pressures developed by this pump. Check all hoses for damage or wear. Be certain dispensing device is clean and in proper working condition.

**⚠ WARNING** STATIC SPARK. Can cause explosion resulting in severe injury or death. Ground pump and pumping system.

- Sparks can ignite flammable material and vapors.
- The pumping system and object being sprayed must be grounded when it is pumping, flushing, recirculating or spraying flammable materials such as paints, solvents, lacquers, etc. or used in a location where surrounding atmosphere is conducive to spontaneous combustion. Ground the dispensing valve or device, containers, hoses and any object to which material is being pumped.
- 666056-XXX and 66605H-XXX Groundable Acetal pumps: Use the pump grounding screw provided. Connect a 12 ga. (min.) wire (kit is included) to a good earth ground source.
- Secure pump, connections and all contact points to avoid vibration and generation of contact or static spark.
- Consult local building codes and electrical codes for specific grounding requirements.
- After grounding, periodically verify continuity of electrical path to ground. Test with an ohmmeter from each component (e.g., hoses, pump, clamps, container, spray gun, etc.) to ground to insure continuity. Ohmmeter should show 0.1 ohms or less.
- Submerge the outlet hose end, dispensing valve or device in the material being dispensed if possible. (Avoid free streaming of material being dispensed.)
- Use hoses incorporating a static wire.
- Use proper ventilation.
- Keep inflammables away from heat, open flames and sparks.
- Keep containers closed when not in use.

**⚠ WARNING** Pump exhaust may contain contaminants. Can cause severe injury. Pipe exhaust away from work area and personnel.

- In the event of a diaphragm rupture material can be forced out of the air exhaust muffler.
- Pipe the exhaust to a safe remote location when pumping hazardous or inflammable materials.
- Use a grounded 3/8" minimum i.d. hose between the pump and the muffler.

**⚠ WARNING** HAZARDOUS PRESSURE. Can result in serious injury or property damage. Do not service or clean pump, hoses or dispensing valve while the system is pressurized.

- Disconnect air supply line and relieve pressure from the system by opening dispensing valve or device and / or carefully and slowly loosening and removing outlet hose or piping from pump.

**⚠ WARNING** HAZARDOUS MATERIALS. Can cause serious injury or property damage. Do not attempt to return a pump to the factory or service center that contains hazardous material. Safe handling practices must comply with local and national laws and safety code requirements.

- Obtain Material Safety Data Sheets on all materials from the supplier for proper handling instructions.

**⚠ CAUTION** Verify the chemical compatibility of the pump wetted parts and the substance being pumped, flushed or recirculated. Chemical compatibility may change with temperature and concentration of the chemical(s) within the substances being pumped, flushed or circulated. For specific fluid compatibility, consult the chemical manufacturer.

**⚠ CAUTION** Maximum temperatures are based on mechanical stress only. Certain chemicals will significantly reduce maximum safe operating temperature. Consult the chemical manufacturer for chemical compatibility and temperature limits. Refer to Pump Data on page 1 of this manual.

**⚠ CAUTION** Be certain all operators of this equipment have been trained for safe working practices, understand it's limitations, and wear safety goggles / equipment when required.

**⚠ CAUTION** Do not use the pump for the structural support of the piping system. Be certain the system components are properly supported to prevent stress on the pump parts.

- Suction and discharge connections should be flexible connections (such as hose), not rigid piped, and should be compatible with the substance being pumped.

**⚠ CAUTION** Prevent unnecessary damage to the pump. Do not allow pump to operate when out of material for long periods of time.

- Disconnect air line from pump when system sits idle for long periods of time.

**⚠ CAUTION** Use only genuine ARO replacement parts to assure compatible pressure rating and longest service life.

**NOTICE** Install the pump in the vertical position. The pump may not prime properly if the balls do not check by gravity upon start-up.

**NOTICE** Re-torque all fasteners before operation. Creep of housing and gasket materials may cause fasteners to loosen. Re-torque all fasteners to insure against fluid or air leakage.

**NOTICE** Replacement warning labels are available upon request: "Static Spark" PN \ 93616-1, "Diaphragm Rupture" PN \ 93122.

**⚠ WARNING** = Hazards or unsafe practices which could result in severe personal injury, death or substantial property damage.

**⚠ CAUTION** = Hazards or unsafe practices which could result in minor personal injury, product or property damage.

**NOTICE** = Important installation, operation or maintenance information.

---

---

## GENERAL DESCRIPTION

---

The ARO diaphragm pump offers high volume delivery even at low air pressure and a broad range of material compatibility options available. Refer to the model and option chart. ARO pumps feature stall resistant design, modular air motor / fluid sections.

Air operated double diaphragm pumps utilize a pressure differential in the air chambers to alternately create suction and positive fluid pressure in the fluid chambers. Ball checks insure a positive flow of fluid.

Pump cycling will begin as air pressure is applied and it will continue to pump and keep up with the demand. It will build and maintain line pressure and will stop cycling once maximum line pressure is reached (dispensing device closed) and will resume pumping as needed.

Models 666056-X and 66605H-X: The Acetal material used in these pumps contains Stainless Steel fibers. It's conductivity allows it to be connected to a suitable ground. A ground screw and ground wire kit is provided for this.

---

---

## AIR AND LUBE REQUIREMENTS

---

- A filter capable of filtering out particles larger than 50 microns should be used on the air supply. There is no lubrication required other than the "O" ring lubricant which is applied during assembly or repair.
- If lubricated air is present, make sure that it is compatible with the Nitrile "O" rings in the air motor section of the pump.

---

---

## OPERATING INSTRUCTIONS

---

- Always flush the pump with a solvent compatible with the material being pumped if the material being pumped is subject to "setting up" when not in use for a period of time.
- Disconnect the air supply from the pump if it is to be inactive for a few hours.
- The outlet material volume is governed not only by the air supply but also by the material supply available at the inlet. The material supply tubing should not be too small or restrictive. Be sure not to use hose which might collapse.
- When the diaphragm pump is used in a forced-feed (flooded inlet) situation, it is recommended that a "Check Valve" be installed at the air inlet.
- Secure the diaphragm pump legs to a suitable surface to insure against damage by vibration.

---

---

## MAINTENANCE

---

- Certain ARO "Smart Parts" are indicated which should be available for fast repair and reduction of down time.
- Provide a clean work surface to protect sensitive internal moving parts from contamination from dirt and foreign matter during service disassembly and reassembly.
- Keep good records of service activity and include pump in preventive maintenance program.
- Service Kits are available to service two separate Diaphragm Pump functions: 1. AIR SECTION, 2. FLUID SECTION. The Fluid Section is divided further to match typical active MATERIAL OPTIONS.

---

---

## DUCKBILL CHECK VALVES (OPTIONAL)

---

Pump models with the suffix (-0CX or -0DX) come equipped with duckbill type checks. Standard duckbill pumps are shipped with the material inlet in the top and the material outlet on the bottom manifold. To change the direction of flow, disassemble the pump as instructed in the FLUID SECTION and reassemble as described below. A pump that was factory built with balls and seats can be retro-fitted with duckbill type check valves by purchasing the necessary parts and installing them as shown.

### Reassembly:

The duckbills may be installed in either direction to produce flow from top to bottom of the pump or from bottom to top of the pump. In either case, **all of the (42) duckbills must point in the same direction.**

### Flow from Top to Bottom: (see page 5)

1. With (15) fluid caps installed, stand the pump upside down.
2. Place (21) insert into (42) duckbill and slide (41) sleeve over (42) duckbill.
3. Slide the complete check assembly into the fluid cap bore with the (21) insert end first. [Duckbills (42) point up.]
4. Position (19) "O" ring over (41) sleeve.
5. Attach (35) manifold feet / (36) swivel assembly to the fluid caps.
6. Turn pump over to right side up position.
7. Assemble duckbill check as in step #1.
8. Slide the complete check assembly into the fluid cap bore with the (41) sleeve end first. [Duckbill is pointing down toward fluid cap cavity.]
9. Position (19) "O" ring around (21) insert.
10. Attach (34) manifold / (36) swivel assembly to fluid cap.

### Flow from Bottom to Top: (Inlet Bottom - Outlet Top)

To reverse flow direction, slide check valve assemblies into the (15) fluid caps backwards from what is indicated in steps #2 and #7. In step #2, the (42) duckbills will be pointing down and in step #7, they will be pointing up.

## PARTS LIST / 66605X-X FLUID SECTION

☆ 637140-XX FLUID SECTION SERVICE KITS include: BALLS (see "BALL OPTIONS", refer to -XX in chart below), DIAPHRAGMS (see "DIAPHRAGM OPTIONS", refer to -XX in chart below), plus "O" ring items: 2, 19, 20, 33 and 93706-1 Key-Lube grease.

SEAT OPTIONS				BALL OPTIONS							
ITEM "21"				ITEM "22" (3/4" dia.) (Service Kit -XX)							
-XXX	Seat	Qty	[Mtl]	-XXX	Ball	Qty	[Mtl]	-XXX	Ball	Qty	[Mtl]
-2XX	93409-1	(4)	[SS]	-X1X	93100-1	(4)	[N]	-XAX	93410-1	(4)	[SS]
-3XX	93098-1	(4)	[P]	-X2X	93100-2	(4)	[B]	-XEX	93100-E	(4)	[SP]
-34X / -3AX	93098-10	(4)	[P]	-X3X	93100-3	(4)	[V]	ITEM "42" (Duckbill)			
-4XX	93098-4	(4)	[PK]	-X4X	93100-4	(4)	[T]				
-6XX	93098-3	(4)	[D]	-X5X	93100-5	(4)	[E]	-OCX	93114-1	(4)	[N]
-0XX	93115-1	(4)	[P]	-X8X	93100-8	(4)	[U]	-ODX	93114-2	(4)	[B]

MATERIAL CODE	
[B]	Nitrile
[D]	Acetal
[E]	E.P.R.
[F]	Flouraz
[GA]	Groundable Acetal
[GFN]	Glass Filled Nylon
[H]	Hytre
[N]	Neoprene
[P]	Polypropylene
[PK]	Pure Kynar
[SP]	Santoprene
[SS]	Stainless Steel
[T]	Teflon
[U]	Polyurethane
[V]	Viton

DIAPHRAGM OPTIONS							
66605X-XXX	☆ SERVICE KITS -XX = (Ball or Duckbill) -XX = (Diaphragm)	"7" / "8"		"19"	"20"	"33" *	
		Diaphragm (2)	[Mtl]	"O" Ring (4) 1-5/16" o.d.	"O" Ring (2) 1-1/8" o.d.	"O" Ring (4) 1-3/16" o.d.	[Mtl]
-XX1	637140-X1	93113	[N]	Y325-122	Y325-119	Y325-120	[B]
-XX2	637140-X2	93465-G	[B]	Y325-122	Y325-119	Y325-120	[B]
-XX3	637140-X3	93581-3	[V]	Y327-122	Y327-119	Y327-120	[V]
666053-, 66605J-XX4	637140-X4	93111 / 93465	[T/SP]	93265	Y328-119	94749	[T]
666056-, 66605H-XX4	637140-X4	93111 / 93465	[T/SP]	93764	93933	95129	[F]
666057-, 66605K-XX4	637140-X4	93111 / 93465	[T/SP]	93265	Y328-119	94749	[T]
-XX5	637140-X5	93760	[E]	93763	93761	93762	[E]
-XX8	637140-X8	93112	[U]	93119	93117	93118	[U]
-XX9	637140-X9	93465-9	[H]	Y325-122	Y325-119	Y325-120	[B]
-XXB	637140-XB	93465	[SP]	93763	93761	93762	[E]
-0X1	637140-C1, D1	93113	[N]	Y325-122	Not Req'd	Y325-120	[B]
-0X2	637140-C2, D2	93465-G	[B]	Y325-122	Not Req'd	Y325-120	[B]
-0X4	637140-C4, D4	93111 / 93465	[T/SP]	Y325-122	Not Req'd	94749	[T]
-0X8	637140-C8, D8	93112	[U]	93119	Not Req'd	93118	[U]
-0XB	637140-CB, DB	93465	[SP]	Y325-122	Not Req'd	Y325-120	[B]

- Not shown
- ⦿ Quantity = 22

\* Item "33" "O" rings are not used on models 66605H-XXX, 66605J-XXX and 66605K-XXX.

WETTED COMMON PARTS														
Item	Description (size in inches)	Qty	POLYPROPYLENE				GROUNDABLE ACETAL				PURE KYNAR			
			666053-XXX		66605J-XXX		666056-XXX		66605H-XXX		666057-XXX		66605K-XXX	
			Part No.	Mtl	Part No.	Mtl	Part No.	Mtl	Part No.	Mtl	Part No.	Mtl	Part No.	Mtl
□ 1	Rod	(1)	93084	[SS]	93084	[SS]	93084	[SS]	93084	[SS]	93084	[SS]	93084	[SS]
2	"O" Ring (3/32" x 5/8" o.d.)	(1)	Y325-111	[B]	Y325-111	[B]	Y325-111	[B]	Y325-111	[B]	Y325-111	[B]	Y325-111	[B]
5	Washer (2" o.d.)	(2)	94645	[GFN]	94645	[GFN]	94645	[GFN]	94645	[GFN]	94645	[GFN]	94645	[GFN]
□ 6	Diaphragm Nut (5/16" - 18)	(2)	93103-1	[P]	93103-1	[P]	93103-3	[D]	93103-3	[D]	93103-4	[PK]	93103-4	[PK]
15	Fluid Cap (includes 26 & 124)	(2)	93105-1	[P]	93105-1	[P]	93105-11	[GA]	93105-11	[GA]	93105-9	[PK]	93105-9	[PK]
26	Bolt (5/16" - 18 x 1-1/2")	(8)	93109	[SS]	93109	[SS]	93109	[SS]	93109	[SS]	93109	[SS]	93109	[SS]
29	Nut (5/16" - 18)	(2)	-----	---	-----	---	Y12-5-S	[SS]	Y12-5-S	[SS]	-----	---	-----	---
34	Manifold, Outlet (top)	(2)	93102-1	[P]	-----	---	93102-6	[GA]	-----	---	93102-4	[PK]	-----	---
□ 35	Manifold, Foot (bottom)	(2)	93106-1	[P]	-----	---	93106-6	[GA]	-----	---	93106-4	[PK]	-----	---
□ 36	Swivel	(2)	93101-1	[P]	-----	---	93101-6	[GA]	-----	---	93101-4	[PK]	-----	---
□ 37	Clamp	(8)	93099	[SS]	-----	---	93099	[SS]	-----	---	93099	[SS]	-----	---
38	Bolt (#10 - 24 x 1-1/2")	(8)	Y84-303-T	[SS]	-----	---	Y84-303-T	[SS]	-----	---	Y84-303-T	[SS]	-----	---
39	Nut (#10 - 24)	(8)	Y22-10-S	[SS]	-----	---	Y22-10-S	[SS]	-----	---	Y22-10-S	[SS]	-----	---
41a	Ball Cage	(4)	93097-1	[P]	93097-1	[P]	93097-3	[D]	93097-3	[D]	93097-4	[PK]	93097-4	[PK]
41b	Sleeve (models 66605X-0XX)	(4)	93120-1	[P]	93120-1	[P]	-----	---	-----	---	-----	---	-----	---
43	Ground Strap	(1)	-----	---	-----	---	92956-1	[SS]	92956-1	[SS]	-----	---	-----	---
■ 57	Ground Kit Assembly	(1)	-----	---	-----	---	66885-1	---	66885-1	---	-----	---	-----	---
60	Manifold, Inlet (bottom)	(1)	-----	---	93802-1	[P]	-----	---	93802-2	[GA]	-----	---	93802-3	[PK]
61	Manifold, Outlet (top)	(1)	-----	---	93801-1	[P]	-----	---	93801-2	[GA]	-----	---	93801-3	[PK]
62	Flange Nut (5/16" - 18)	(24)	93886	[SS]	93886	[SS]	93886 (⦿)	[SS]	93886 (⦿)	[SS]	93886	[SS]	93886	[SS]
63	Plug (1/2 - 14 N.P.T.)	(6)	-----	---	93897-1	[P]	-----	---	93897-2	[D]	-----	---	93897-3	[PK]

□ "Smart Parts" keep these items on hand in addition to the service kits for fast repair and reduction of down time.

# PARTS LIST / 66605X-X FLUID SECTION

COLOR CODE		
MATERIAL	DIAPHRAGM COLOR	BALL COLOR
ACETAL	N/A	Orange
NITRILE	Red (-)	Red (+)
E.P.R.	Blue (-)	Blue (+)
HYTREL	Cream	N/A
NEOPRENE	Green (-)	Green (+)
SANTOPRENE	Tan	Tan
T.F.E. (Teflon)	White	White
URETHANE	Clear	Red
VITON	Yellow (-)	Yellow (+)
	(-) STRIPE	(+) DOT

FOR THE AIR MOTOR SECTION  
SEE PAGES 6 & 7

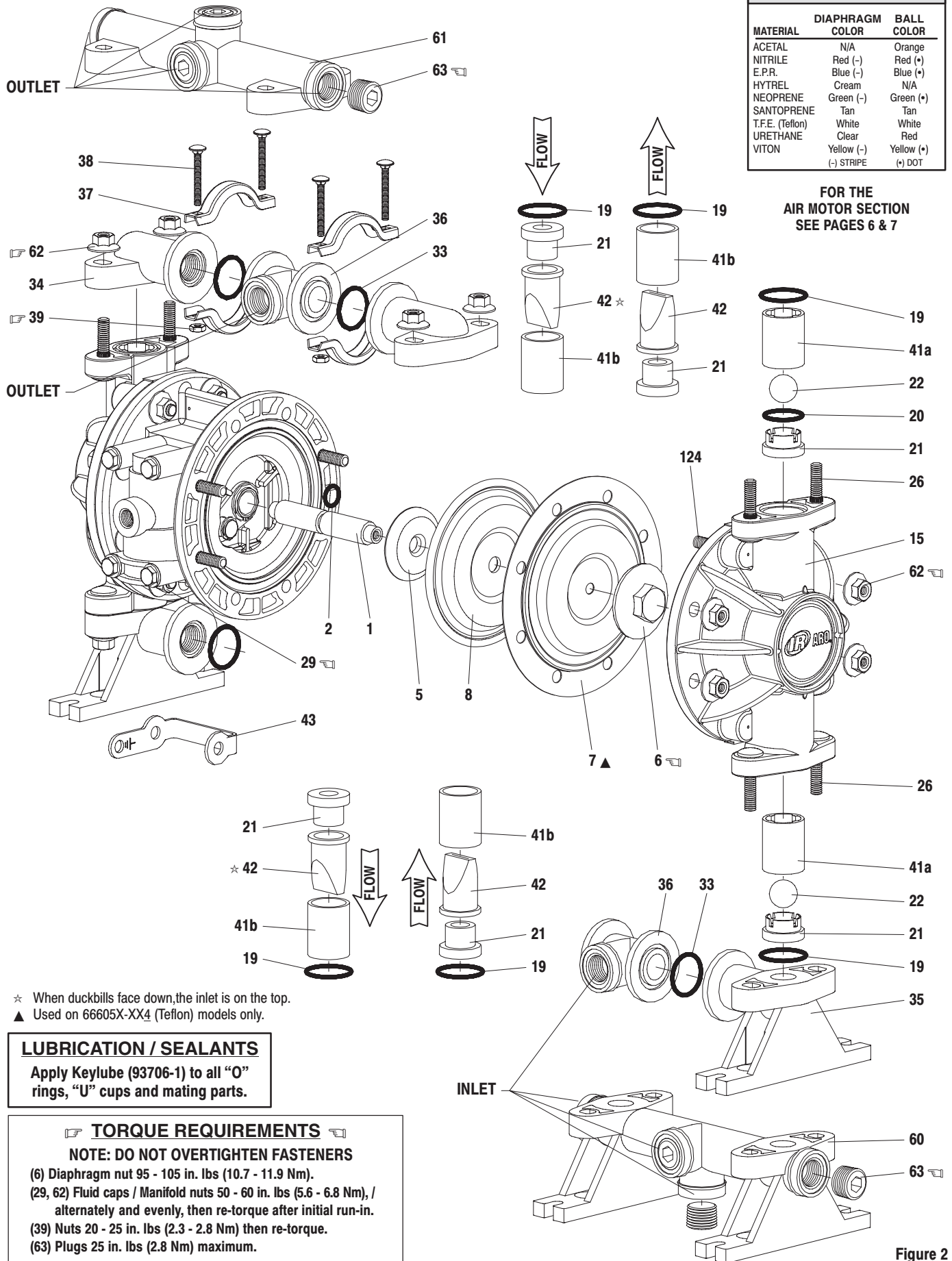

★ When duckbills face down, the inlet is on the top.  
▲ Used on 66605X-XX4 (Teflon) models only.

### LUBRICATION / SEALANTS

Apply Keylube (93706-1) to all "O" rings, "U" cups and mating parts.

### TORQUE REQUIREMENTS

NOTE: DO NOT OVERTIGHTEN FASTENERS

- (6) Diaphragm nut 95 - 105 in. lbs (10.7 - 11.9 Nm).
- (29, 62) Fluid caps / Manifold nuts 50 - 60 in. lbs (5.6 - 6.8 Nm), / alternately and evenly, then re-torque after initial run-in.
- (39) Nuts 20 - 25 in. lbs (2.3 - 2.8 Nm) then re-torque.
- (63) Plugs 25 in. lbs (2.8 Nm) maximum.

Figure 2

## PARTS LIST / 66605X-X AIR MOTOR SECTION

(✓) Indicates parts included in 637141 Air Section Repair Kit.

### AIR SECTION PARTS

Item	Description (size in inches)	Qty	Part No.	[Mtl]
101	Motor Body	(1)	93091	[P]
✓ 102	"O" Ring (3/32" x 1" o.d.)	(2)	Y325-117	[B]
□ 103	Sleeve	(1)	93087	[Bz]
□ 104	Snap Ring (13/16")	(2)	37285	[C]
111	Spool	(1)	93085	[D]
118	Pilot Rod	(1)	93088	[C]
✓ 119	"O" Ring (1/8" x 3/4" o.d.)	(4)	93075	[U]
□ 120	Spacer	(3)	115959	[Z]
✓ 122	Snap Ring (1/2")	(2)	77802	[C]
124	Stud (5/16" - 18 x 1-17/32") (see page 5)	(8)	93249	[SS]
129	Muffler Assembly	(1)	66972	[P]
129☆	Exhaust Cover (see note 2)		93092	[PS]
✓ 130	Gasket	(1)	93107	[SY]
131	Bolt (5/16" - 18 x 1-1/4")	(8)	93095	[SS]
✓ 132	Gasket (see note 1)	(1)	93339-1	[B]

Item	Description (size in inches)	Qty	Part No.	[Mtl]
133	Washer (9/32" i.d.)	(4)	93096	[SS]
134	Bolt (1/4" - 20 x 5")	(4)	Y6-419-T	[SS]
135	Valve Block	(1)	93090	[P]
136	Plug	(1)	93086	[D]
✓ 137	"O" Ring (3/32" x 1-1/2" o.d.)	(1)	Y325-125	[B]
✓ 138	Packing, "U" Cup (1/8" x 1" o.d.)	(1)	94395	[U]
✓ 139	Packing, "U" Cup (1/8" x 1.427" o.d.)	(1)	93116	[B]
✓ 140	Valve Insert	(1)	93276	[CK]
✓ 141	Valve Plate	(1)	93275	[CK]
142	Washer	(2)	116038	[Z]
143	Plate	(2)	93089	[SS]
201	Muffler (see note 2)		93110	[C]
✓	Keylube "O" Ring Lubricant		93706-1	
	10 Pack of Keylube		637175	

### DIAPHRAGM PUMP SERVICE

#### GENERAL SERVICE NOTES:

- Inspect and replace old parts with new parts as necessary. Look for deep scratches on metallic surfaces, and nicks or cuts in "O" rings.
  - 7/16" wrench, 1/2" wrench, 7/16" socket, 1/2" socket, torque wrench (measuring inch pounds), "O" ring pick.

### FLUID SECTION DISASSEMBLY

- Remove (34) top manifold / (36) swivel assembly.  
Note: Manifold options involve single piece manifolds (60 / 61) or three piece swivel type manifolds with clamps.
- Remove (41) ball cages, (22) balls, (19 and 20) "O" rings and (21) seats. Note: If cages are difficult to remove at this step, it may be helpful to proceed through step 5 and remove them once they are accessible from the inside of the fluid cap.
- Remove (35) bottom manifolds / (36) swivel assembly.
- Remove (19) "O" rings, (21) seats and (22) balls.
- Remove (15) fluid caps.
- Remove (6) diaphragm nut, (8) [(7) Teflon models only] diaphragm(s) and (5) diaphragm washer from (1) diaphragm connecting rod.
- Remove (1) connecting rod from air motor.
- Carefully remove remaining (6) diaphragm nut, (8) [(7) Teflon models] diaphragm and (5) diaphragm washer from (1) connecting rod. Do not mar surface of connecting rod.
- Remove (2) "O" ring from connecting rod.
- Remove (37) clamps from top and bottom manifold / swivel assemblies.
- Remove (33) "O" rings from (36) swivels.

Note 1: Part No.93339-1 One-Piece Gasket replaces the following parts (not shown) in models manufactured prior to October 1988, Y325-10 (4), Y325-12, 93093, 93094, Y325-8.

Note 2: The (129☆) Exhaust Cover and (201) Muffler were standard until 9/92. They are available separately for service or piped exhaust applications.

Note 3: A Major Valve Service Assembly is available separately which includes items: 111, 132, 135 - 141. Order part no 66362.

#### MATERIAL CODE

[B] = Nitrile	[D] = Acetal	[SY] = Syn-Seal
[Bz] = Bronze	[P] = Polypropylene	[U] = Polyurethane
[C] = Carbon Steel	[PS] = Polyester	[Z] = Zinc
[CK] = Ceramic	[SS] = Stainless Steel	

### FLUID SECTION REASSEMBLY

- Reassemble In reverse order.
- Lubricate (1) connecting rod and (2) "O" ring with Key-Lube or equivalent "O" ring lubricant.
- Install (5) diaphragm washers with i.d. chamfer toward diaphragm.
- When replacing Teflon diaphragms, install the 93465 Santoprene diaphragm behind the Teflon diaphragm.
- When installing (41) cage, ball guides must line up with notches in (21) seat to prevent damage.
- Before installing (35), (34) manifolds, (19) "O" ring should be properly seated on the o.d. of (41) ball cage.
- Before tightening (39) nut and (38) carriage bolts on (36) swivels, attach the manifold / swivel assembly to the fluid caps. Rotate (36) swivel to desired position and tighten each of the nuts approx. 8 - 9 turns, then finish tightening (29) nuts.

# PARTS LIST / 66605X-X AIR MOTOR SECTION

**TORQUE REQUIREMENTS**  
**NOTE: DO NOT OVERTIGHTEN FASTENERS.**  
 (134) Torque to 15 - 20 in. lbs (1.7 - 2.3 Nm), wait 10 minutes, then re-torque to 15 - 20 in. lbs (1.7 - 2.3 Nm).

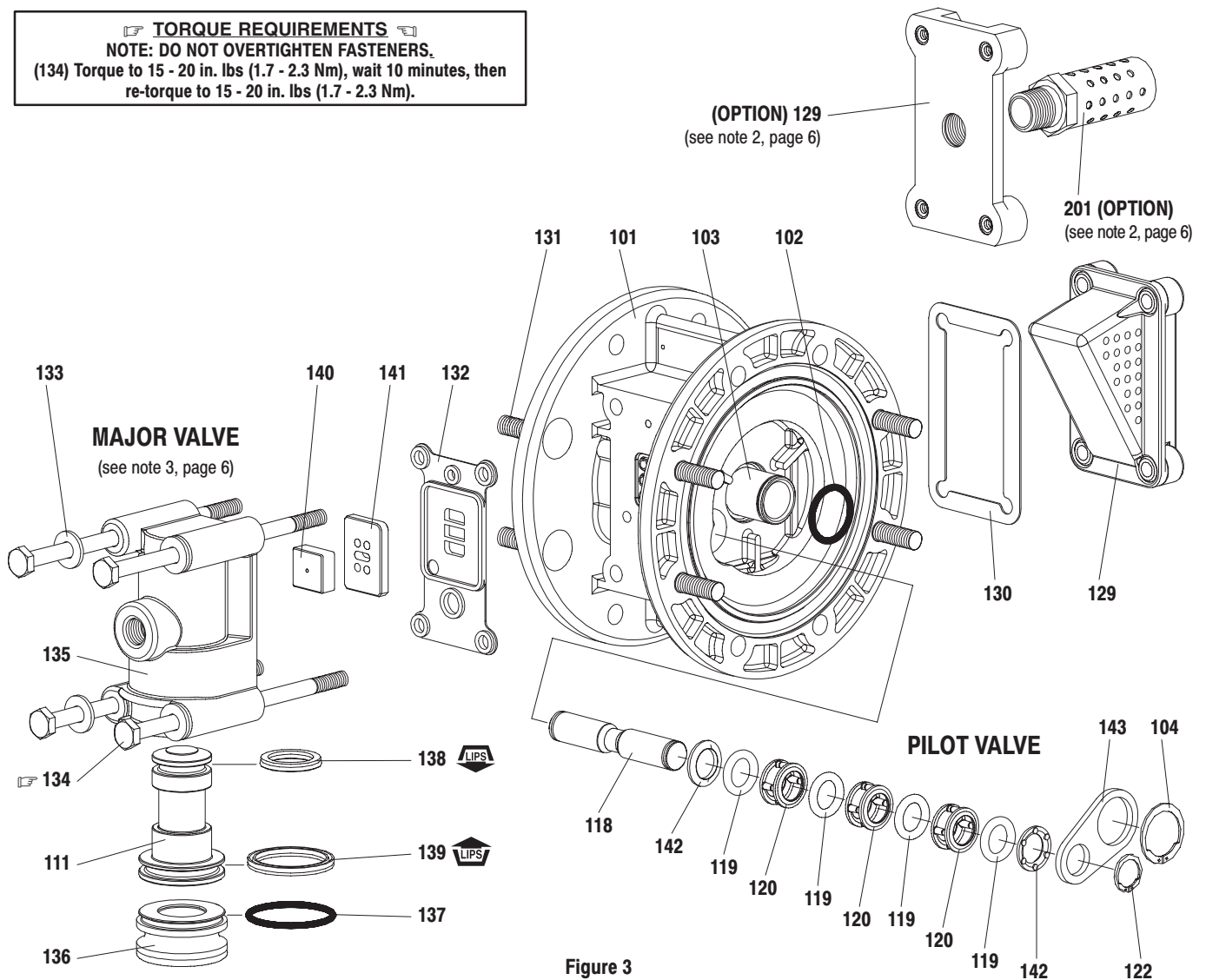

Figure 3

## AIR MOTOR SECTION SERVICE

Service is divided into two parts - 1. Pilot Valve, 2. Major Valve.  
 • Air Motor Section Service is continued from Fluid Section repair.

## PILOT VALVE DISASSEMBLY

1. Remove (122) and (104) snap rings.
2. Remove (143) plates.
3. Remove (103) sleeve and (102) "O" rings.
4. Remove (118) piston, (142) washers, (119) "O" rings and (120) spacers from (101) center body.

## PILOT VALVE REASSEMBLY

1. Assemble (119) "O" rings, (120) spacers and (142) washers on (118) pilot rod.
2. Insert the stack into the (101) body. Sleeve (103) may be used to assist pressing stack into body.
3. Install (103) sleeve and (102) "O" rings into (101) body.
4. Install (143) plates and (122) and (104) snap rings.

## MAJOR VALVE DISASSEMBLY

1. Remove (129) exhaust cover and (130) gasket.
2. Pull (135) valve block assembly from (101) body.
3. Remove (134) bolts, (133) washers and (132) gasket from (135) valve block.
4. Remove (141) valve plate and (140) valve insert.
5. Remove (136) plug and (111) spool.

## MAJOR VALVE REASSEMBLY

1. Install new (139) and (138) "U" cups on (111) spool - **LIPS MUST FACE EACH OTHER.**
2. Insert (111) spool into (135) valve block.
3. Install (137) "O" ring on (136) plug, insert plug into (135) valve block.
4. Install (140) valve insert and (141) valve plate into (135) valve block. Note: After 9/92, parts (140, 141) are white (ceramic), the dished side of the (140) valve insert should be against the shiny face of (141) valve plate for best performance.
5. Replace (132) gasket and install valve block assembly on (101) body.

## TROUBLE SHOOTING

### Product discharged from air exhaust.

- Check for diaphragm rupture.
- Check tightness of (6) diaphragm nut.

### Air Bubbles in Product Discharge.

- Check connections of suction plumbing.
- Check band clamps on intake manifold.
- Check "O" rings between intake manifold and fluid caps.
- Check tightness of diaphragm nut.

### Pump blows air out main exhaust when stalled on either stroke.

- Check "U" cups on (111) spool in major valve.
- Check (141) valve plate and (140) insert for wear.
- Check (103) sleeve and (2) "O" ring on diaphragm connecting rod.
- Check (119) "O" rings on (118) piston for wear.

### Low output volume.

- Check air supply.
- Check for plugged outlet hose.
- For the pump to prime itself, it must be mounted in the vertical position so that the balls will check by gravity.
- Check for pump cavitation - suction pipe should be 1/2" min. or larger if high viscosity fluids are being pumped. Suction hose must be non-collapsible type, capable of pulling a high vacuum.
- Check all joints on intake manifolds and suction connections. These must be airtight.
- Check for sticking or improperly seating check valves.
- If pump cycles at a high rate or runs erratically, check (119) piston "O" rings for wear.

## DIMENSIONAL DATA

Dimensions shown are for reference only, they are shown in inches and millimeters (mm).

