

Telephone 800-500-9311
Telephone 864-573-9200
Fax 864-573-9299

OEC FLUID HANDLING INC.

SUBSIDIARY OF OILMEN'S EQUIPMENT CORP.
www.oecfh.com

140 Cedar Springs Rd.
P. O. Box 2807
Spartanburg, SC 29304

■ Stocked Items 11/06/03

PD Pumps

- ARO Ingersoll-Rand
- Blackmer Vane
Blackmer/Abaque Peristaltic
Blackmer "C" Eccentric Disc
- Alfa Laval-TriClover Lobe
- APV Lobe
- Tuthill Gear
Tuthill Lobe
MonoFlo Progressive Cavity

Centrifugal Pumps

- Alfa Laval-TriClover Sanitary
- APV Crepaco
- Deming End Suction
Deming Vertical Turbine
- Griswold ANSI Pumps
- MP Pump

Specialty Pumps

Flux Drum

Petroleum-Fuel Pumps

- Gorman-Rupp
- Dresser Wayne Corp
- Red Jacket
Graco
William Wilson Gasboy

Hand Pumps

- Blackmer
- Tokhiem
- Tuthill Fill-Rite

Storage Tanks

Stainless Steel ASME
UL & ASME Carbon Steel
Fiberglass Tanks
Chem-Tainer Poly Tanks
Assmann Poly Tanks
Snyder Poly Tanks

Tank Fittings & Vents

- OPW Engineered Systems
EMCO Wheaton
Morrison Bros
Protectoseal

Mechanical Seals

Utex

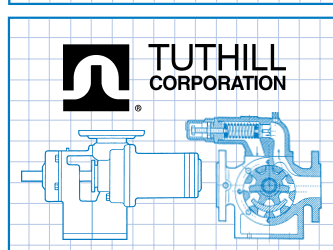
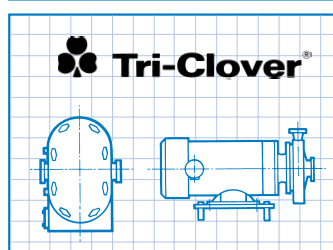
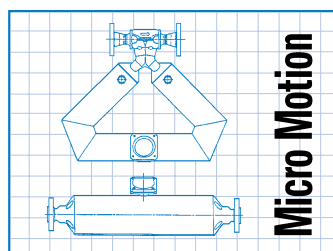
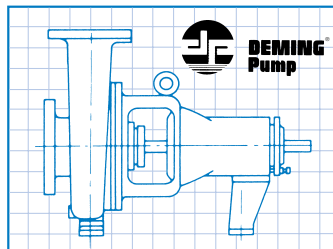
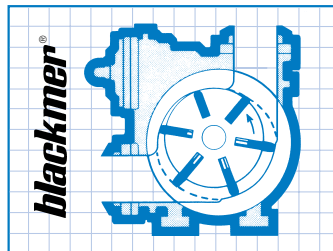
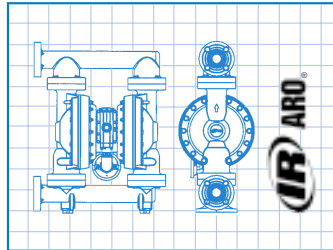

Meters & Instrumentation

- Micro Motion Coriolis
- Neptune Actaris PD
- Tuthill FPP PD
- Liquid Controls PD
Halliburton Turbine
Rosemount
Pressure Transmitters
Flow Transmitters
Temperature Transmitters
Level Transmitters

Sanitary Products

- Alfa Laval-TriClover Pumps
- Alfa Laval-TriClover Fittings
Alfa Laval-TriClover Valves
APV Pumps
APV Valves
APV Homogenizers
B & A Flexible Sanitary Hose

Liquid Level Gauges

- Protectoseal
Pneumercator
Moorman Bros
Milltronics/Siemens
Rosemount Level Transmitters

Hose & Reels

- Goodyear Hose
- Hannay Reels
Lawrence Composite Hose

Filters

Filtration Group Bag Filters

Mixers

Brawn Portable & Sanitary
Proquip Top Entry Agitators

Liquid Loaders & Platforms

OPW Engineered Systems
Green Manufacturing

Rotary Unions

Deublin

Custom Liquid Systems

For liquid transfer, batching &
process metering

Performance Guaranteed

CHARLOTTE, NC ■ SPARTANBURG, SC ■ GREENSBORO, NC

BLACKMER C-SERIES PUMPS

INSTALLATION, OPERATION, AND MAINTENANCE INSTRUCTIONS

MODELS: C24-I, C36-I

STAINLESS STEEL CONSTRUCTION

Section	1000
Effective	December 2001
Replaces	October 2001



C SERIES STAINLESS STEEL

NOTE: Numbers in parentheses following individual parts indicate reference numbers on Blackmer C Series Parts Lists.

TABLE OF CONTENTS

	<i>Page</i>
SAFETY DATA	1-2
PUMP DATA	2
Technical Data	2
Initial Start Up Information	2
INSTALLATION	2-3
Pre-Installation Cleaning	2
Location and Piping	2
Pump Mounting	3
Bypass Valve Installation	3
Coupling Alignment	3
Pump Rotation	3
Port Orientation	3
OPERATION	4
Pre-Start Up Check List	4
Pump Speed	4
Start Up Procedures	4
Flushing the Pump	4
MAINTENANCE	5-8
Lubrication	5
Pump Disassembly	5
Pump Handling	5
Lip Seal Replacement	6
Bellows Inspection	7
Pump Assembly	7
GENERAL PUMP TROUBLESHOOTING	8

SAFETY DATA



This is a **SAFETY ALERT SYMBOL**.

When you see this symbol on the product, or in the manual, look for one of the following signal words and be alert to the potential for personal injury, death or major property damage.

▲ DANGER

Warns of hazards that **WILL** cause serious personal injury, death or major property damage.

▲ WARNING

Warns of hazards that **CAN** cause serious personal injury, death or major property damage.

▲ CAUTION

Warns of hazards that **CAN** cause personal injury or property damage.

NOTICE:

Indicates special instructions which are very important and must be followed.

NOTICE:

Blackmer C Series pumps MUST only be installed in systems which have been designed by qualified engineering personnel. The system MUST conform to all applicable local and national regulations and safety standards.

This manual is intended to assist in the installation and operation of the Blackmer C Series pumps, and MUST be kept with the pump.

Blackmer C Series pump service shall be performed by qualified technicians ONLY. Service shall conform to all applicable local and national regulations and safety standards.

Thoroughly review this manual, all instructions and hazard warnings, BEFORE performing any work on the Blackmer C Series pumps.

Maintain ALL system and Blackmer C Series pump operation and hazard warning decals.

SAFETY DATA

⚠ WARNING



Hazardous pressure can cause personal injury or property damage.

WHEN PUMP IS RUNNING, DISCONNECTING ANY PART OF THE LIQUID SYSTEM, PIPE, STRAINER, HOSE, NOZZLE, ETC. CAN CAUSE SERIOUS PERSONAL INJURY, DEATH OR MAJOR PROPERTY DAMAGE.

⚠ WARNING



Hazardous or toxic fluids can cause serious injury.

IF PUMPING HAZARDOUS FLUIDS SYSTEM MUST BE FLUSHED PRIOR TO PERFORMING SERVICE.

⚠ WARNING



Hazardous voltage. Can shock, burn or cause death.

FAILURE TO DISCONNECT AND LOCKOUT ELECTRICAL POWER BEFORE ATTEMPTING MAINTENANCE CAN CAUSE SHOCK, BURNS OR DEATH.

⚠ CAUTION



Hazardous pressure can cause personal injury or property damage.

FAILURE TO RELIEVE SYSTEM PRESSURE PRIOR TO PERFORMING PUMP SERVICE OR MAINTENANCE CAN CAUSE PERSONAL INJURY OR PROPERTY DAMAGE.

⚠ WARNING



Hazardous machinery can cause serious personal injury.

FAILURE TO DISCONNECT AND LOCKOUT ELECTRICAL POWER BEFORE REMOVING GUARDS OR ATTEMPTING MAINTENANCE CAN CAUSE SERIOUS PERSONAL INJURY OR DEATH.

PUMP DATA

TECHNICAL DATA

C Series Pump Models	C24-I	C36-I
Maximum Pump Speed (RPM)	450	450
Maximum Working Pressure (Inlet Pressure + Discharge Pressure)	9 bar (130 psi)	6 bar (87 psi)
Maximum Inlet Pressure	1 bar (14.5 psig) 2 bar absolute (29 psia)	
Maximum Temperature	80°C (176°F)	
Maximum Viscosity	2000 cSt (10,000 SSU)	

INITIAL START UP INFORMATION

Model No. _____

Serial No. _____

Date of Installation: _____

Pressure Gauge Reading: _____

Vacuum Gauge Reading: _____

INSTALLATION

NOTICE:

BLACKMER C SERIES PUMPS MUST ONLY BE INSTALLED IN SYSTEMS DESIGNED BY QUALIFIED ENGINEERING PERSONNEL. SYSTEM DESIGN MUST CONFORM WITH ALL APPLICABLE REGULATIONS AND CODES AND PROVIDE WARNING OF ALL SYSTEM HAZARDS.

⚠ WARNING



Hazardous voltage. Can shock, burn or cause death.

- ⚠ Install, ground and wire to local and National Electrical Code requirements.
- ⚠ Install an all-leg disconnect switch near the unit motor.
- ⚠ Disconnect and lockout electrical power before installation or service.

- ⚠ Electrical supply **MUST** match nameplate specifications.
- ⚠ Motors equipped with thermal protection automatically disconnect motor electrical circuit when overload exists. Motor can start unexpectedly and without warning.

PRE-INSTALLATION CLEANING

Foreign matter entering the pump WILL cause extensive damage. The supply tank and intake piping **MUST** be cleaned and flushed prior to pump installation and operation.

LOCATION AND PIPING

An improperly designed piping system or unit installation WILL significantly reduce pump performance and life. Blackmer recommends the following piping system layout and unit installation.

1. To minimize intake losses, locate the pump as close as possible to the source of supply.
2. Piping **MUST** be properly supported to prevent any piping loads being placed on the pump.
3. Intake piping and fittings **MUST** be at least as large in diameter as the pump intake connection.
4. Minimize the number of intake line fittings (valves, elbows, etc.) and piping turns or bends.

INSTALLATION

5. Install vacuum and pressure gauges as close as possible to the intake and discharge ports of the pump housing to check pump operating conditions at start-up.
6. Install a strainer in the inlet line to protect the pump from foreign matter. Placement of intake strainers should facilitate frequent cleaning.
7. Intake and discharge piping MUST be free of all leaks.

PUMP MOUNTING

It is recommended the unit be permanently mounted by securing the base plate with adequately sized anchor bolts to a level concrete floor following recommended industry standards. A solid foundation will reduce system noise and vibration and will improve pump performance. Refer to ANSI/HI standards or a suitable pump handbook for information on typical pump mounting and foundations. Check coupling alignment after pump and base assembly is secured to the foundation.

BYPASS VALVE INSTALLATION

The C Series Stainless Steel pumps are not fitted with an integral relief valve. You must install an external bypass valve on the discharge side of the pump. It is recommended that the bypass be piped back to source.

COUPLING ALIGNMENT

The pump must be directly coupled to a gear and/or driver with a flexible coupling. Consult factory regarding V-belt assemblies. For Clean In Place applications a Variable Frequency Drive is recommended.

Both angular and parallel coupling alignment MUST be maintained between the pump, gear, motor, etc. in accordance with manufacturer's instructions (See Figure 1).

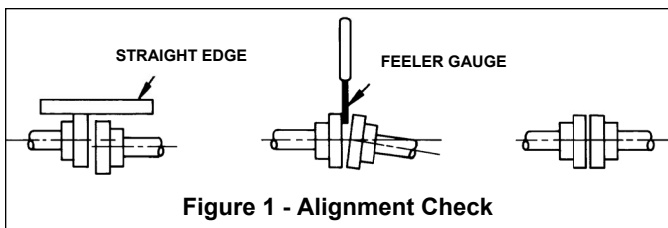

Figure 1 - Alignment Check

1. To check for parallel alignment, the use of a dial indicator is preferred. If a dial indicator is not available use a straight edge. Turn both shafts by hand, checking the reading through one complete revolution. Maximum offset should be less than .005" (.127 mm).
2. To check for angular alignment, insert a feeler gauge between the coupling halves. Check the spacing in 90 degree increments around the coupling (four check points). Maximum variation should not exceed .005" (.127 mm)

PUMP ROTATION

The C Series pumps operate only in a clockwise rotation. To determine clockwise rotation the pump must be observed from the shaft end.

PUMP PORT ORIENTATION

The intake and discharge ports can be individually oriented in several positions. (See Figure 2).

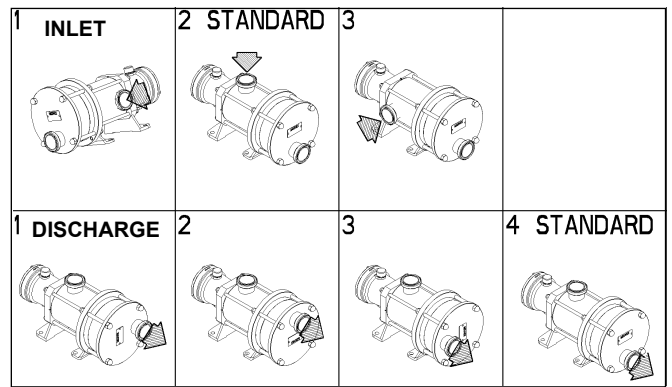
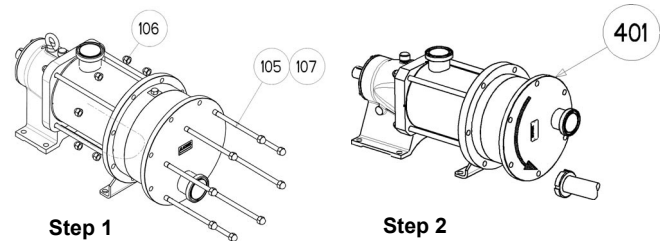

Figure 2 - Port Positions

CHANGING PORT ORIENTATION

Discharge Port

1. Remove the 8 nuts (#106) and the 8 bolts (#105 & #107).
2. Rotate the cover (#401) to achieve desired port position.
3. Replace the 8 bolts (#105 & #107) and the 8 nuts (#106).
4. Refer to Torque Table on page 7 for proper torque settings.



Intake Port

1. Remove the 8 nuts (#106) and the 8 bolts (#105 & #107).
2. Remove the cover plate (#401).
3. Remove the spacer (#402) and seal rings (#205).

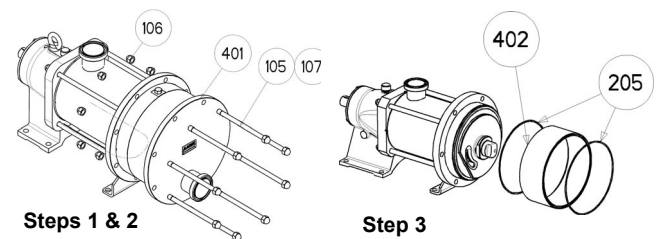

4. Use a 85mm wrench to hold the disc (#301) while removing the nut (#304) with its seal ring (#305).

NOTE: DO NOT ROTATE THE DISC AS DAMAGE TO THE BELLOWS CAN OCCUR.

5. Use a gear puller to remove the disc (#301).

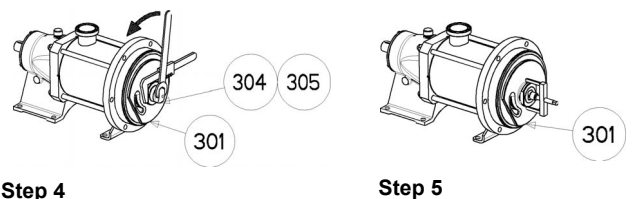

INSTALLATION

6. Remove the cylinder (#201) and seal rings (#113 & #306).
7. Remove the 4 nuts (#115) and the 2 bracket bolts (#108).
8. Use a rubber mallet to tap gently on the bracket (#104) to release the inlet tube (#101).
9. Rotate the intake port to the desired position.

DO NOT STRIKE BELLOWS AS DAMAGE CAN OCCUR

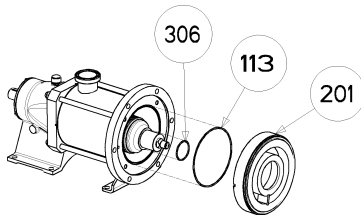

Step 6

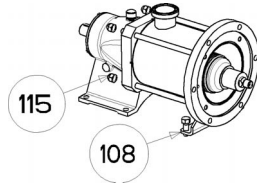

Step 7

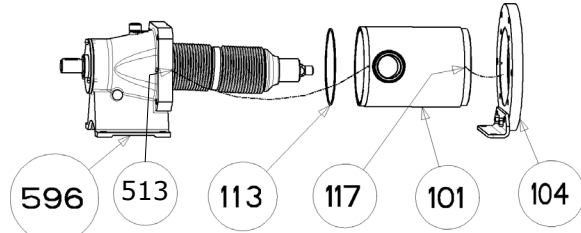

Step 8

10. Reassemble pump as described in "Pump Assembly" section.

Note: Alignment dowels must line up (#117 & #513)

OPERATION

WARNING



Hazardous machinery can cause serious personal injury.

OPERATION WITHOUT GUARDS IN PLACE CAN CAUSE SERIOUS PERSONAL INJURY, MAJOR PROPERTY DAMAGE OR DEATH.

CAUTION



Hazardous pressure can cause personal injury or property damage.

OPERATING PUMP AGAINST A CLOSED VALVE CAN CAUSE SYSTEM COMPONENT FAILURE, PERSONAL INJURY AND PROPERTY DAMAGE.

PRE-START UP CHECK LIST

1. Check the alignment of the pipes to the pump. Pipes should be supported so that they do not spring away or drop down when the pump flanges or union joints are disconnected.
2. To eliminate risk of damage to the pump or contamination of the product, flush the entire installation prior to start up.
3. Inspect complete piping system to ensure that no piping loads are being placed on the pump.
4. Jog the motor to insure proper pump rotation.

PUMP SPEED

The speed of the pump **MUST** not exceed manufacturer's recommendations. The pump speed rating can be found under "**Technical Data**" on page 2.

START UP PROCEDURES

NOTICE:

CONSULT THE "GENERAL PUMP TROUBLESHOOTING" SECTION OF THIS MANUAL IF DIFFICULTIES DURING START UP ARE EXPERIENCED.

1. Start the pump. Priming should occur within one minute.
2. Check the vacuum and pressure gauges to ensure the system is operating within expected parameters. Record the gauge readings in the "Initial Start Up Information" section of this manual for future reference.
3. Inspect piping, fittings, and associated system equipment for leaks, noise, vibration and overheating.
4. Check the flow rate to ensure the pump is operating within the expected parameters.

FLUSHING THE PUMP

To flush the pump, use the following procedure:

1. Allow the pump to evacuate as much fluid as possible.
2. Run cleaning fluid through the pump intake. The cleaning fluid should be compatible with the pump seal-rings. When handling "sticky" fluids that solidify within the pump (i.e., waxes, adhesives, resins, etc.), use a fluid that will prevent solidification of the fluid being transferred and facilitate flushing.
3. To clean the external bypass system you may operate the pump against a closed discharge line for a maximum of 15 seconds.
4. To clean in place apply cleaning solution via an external pump. **DO NOT** exceed a cleaning run time of 25-30 minutes. Run the pump less than 100 rpm. Cycling on and off during the CIP cycle may facilitate cleaning.

MAINTENANCE

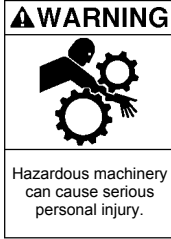

FAILURE TO DISCONNECT AND LOCKOUT ELECTRICAL POWER BEFORE ATTEMPTING MAINTENANCE CAN CAUSE SERIOUS PERSONAL INJURY OR DEATH.

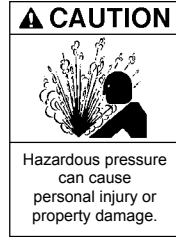

FAILURE TO RELIEVE SYSTEM PRESSURE PRIOR TO PERFORMING PUMP SERVICE OR MAINTENANCE CAN CAUSE PERSONAL INJURY OR PROPERTY DAMAGE.

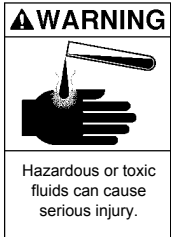

IF PUMPING HAZARDOUS FLUIDS SYSTEM MUST BE FLUSHED PRIOR TO PERFORMING SERVICE.

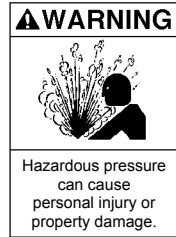

WHEN PUMP IS RUNNING, DISCONNECTING ANY PART OF THE LIQUID SYSTEM, PIPE, STRAINER, HOSE, NOZZLE, ETC. CAN CAUSE SERIOUS PERSONAL INJURY, DEATH OR MAJOR PROPERTY DAMAGE.

NOTICE:

MAINTENANCE SHALL BE PERFORMED BY QUALIFIED TECHNICIANS ONLY, FOLLOWING THE APPROPRIATE PROCEDURES AND WARNINGS AS PRESENTED IN THIS MANUAL.

NOTICE:

FOLLOW ALL HAZARD WARNINGS AND INSTRUCTIONS PROVIDED IN THE "MAINTENANCE" SECTION OF THIS MANUAL.

LUBRICATION

Blackmer C Series pumps are pre-lubricated at the factory. It is recommended that the transmission lubrication be changed every **5000** hours of operation. No other lubrication is necessary.

Use the following procedure to change the transmission lubrication (See Figure 3):

1. Remove the drain plug and seal ring (#773 & #774).
2. Remove the filler cap/strainer (#715).
3. Drain the castor oil from the transmission housing.
4. Replace the drain plug and seal ring.
5. Fill transmission with the following amount of castor oil:

CAUTION: DO NOT OVERFILL

Models C24-I and C36-I	3.3 liters (5.8 pints)
-------------------------------	-------------------------------

6. Replace the filler cap/strainer.

PUMP DISASSEMBLY

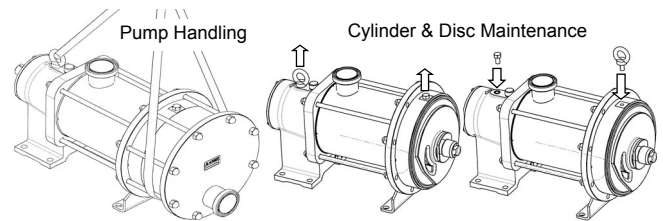

Pump Handling -A lifting eye bolt has been installed to ease in the handling of both the pump and cylinder/piston. You must use lifting slings that are properly rated to handle the weight of the equipment being lifted and equipment must be properly secured with slings before lifting equipment to avoid injury.

Tools Required	C24-I	C36-I
Metric Socket Wrenches	24 mm	24 mm
Flat open end wrench	13-32 mm	13-32 mm
Flat open end wrench	85 mm	85 mm
Small gear puller		

1. Disconnect the intake and discharge pipes from the ports.
2. Remove the 8 nuts (#106) and the 8 bolts (#105 & #107).
3. Remove the cover plate (#401).
4. Remove the spacer (#402) and seal rings (#205).

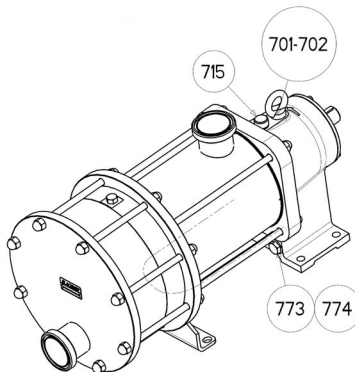
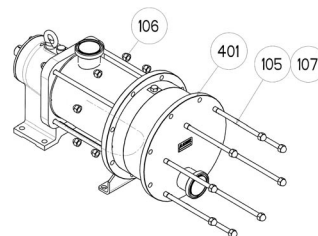
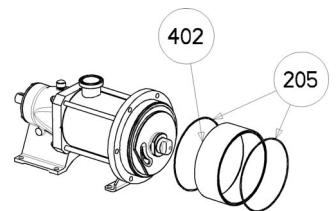

Figure 3



Steps 1 - 3



Step 4

MAINTENANCE

- Use a 85 mm wrench to hold the disc (#301) while removing the nut (#304) with its seal ring (#305).

NOTE: DO NOT ROTATE THE DISC AS DAMAGE TO THE BELLOWS CAN OCCUR.

- Use a gear puller to remove the disc (#301).

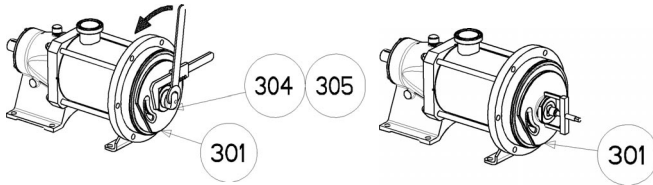

Step 5

Step 6

- Remove the cylinder (#201) and seal rings (#113, #306).

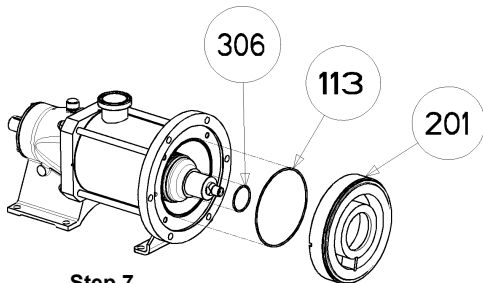

Step 7

- Inspect the disc (#301) and cylinder (#201). Replace if thickness dimensions are **less** than indicated. See Figure 4a and Table 4b for reference number and dimensions.

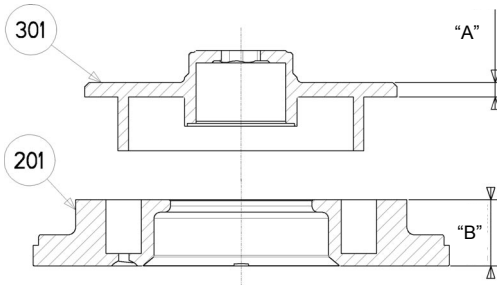

Figure 4a - Disc & Cylinder Dimensions

PUMP MODEL	C24-I	C36-I
#301 Disc - Dimension "A"	9 mm (.354 in)	9 mm (.354 in)
#201 Cylinder - Dimension "B"	67 mm (2.637 in)	95.5 mm (3.759 in)

Table 4b - Disc & Cylinder Dimensions

LIP SEAL REPLACEMENT

- Drain the transmission (see **LUBRICATION** Section).
- Remove the three (3) capscrews (#609).
- Remove the cover (#607) and seal ring (#602).
- Remove the lip seal (#608) from the cover.

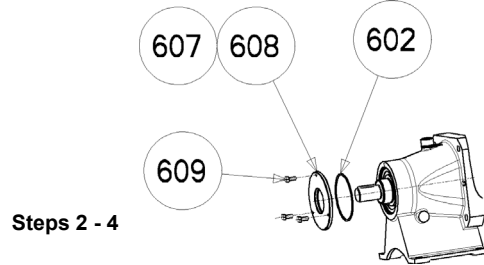

Steps 2 - 4

- Install a new lip seal (#608) using a driver.

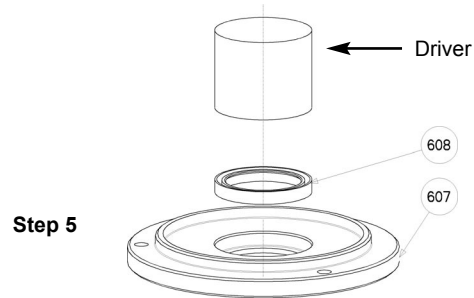

Step 5

- Before reassembling the transmission, examine the ring (#507) for any chips, cracks, scratches, or marks. If present, replace. Break the old ring and remove. Heat the new ring to 90°C (195°F) in an oil or HF bath. Shrink onto the shaft.
- Lubricate the inside diameter of the lip seal.
- Install the seal ring (#602).
- Install the cover (#607).
- Install the drain plug (#774) and seal ring (#773).
- Fill transmission with the following amount of castor oil:

Model C24-I and C36-I	3.3 liters (5.8 pints)
------------------------------	-------------------------------

CAUTION: DO NOT OVERFILL

- Replace the filler cap/strainer.

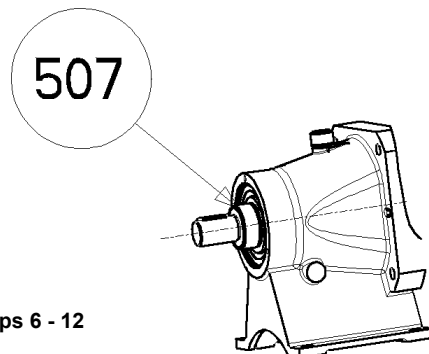

Steps 6 - 12

MAINTENANCE

BELLOWS INSPECTION

1. Disassemble the pump as described in “**Pump Disassembly**” Section.
2. Remove the two foot bolts from the bracket (#108).
3. Remove the 4 nuts (#115) from the drive end bracket.
4. Use a rubber mallet to tap gently on the bracket (#104) to release the inlet tube (#101).
5. Remove the inlet tube. **NOTE: DO NOT STRIKE THE BELLOWS AS DAMAGE CAN OCCUR.**
6. Remove the seal ring (#113).
7. Inspect the bellows. Any trace of damage such as nicks, scratches, deformation or cracking will require factory replacement.

Figure 5 - Bellows Inspection

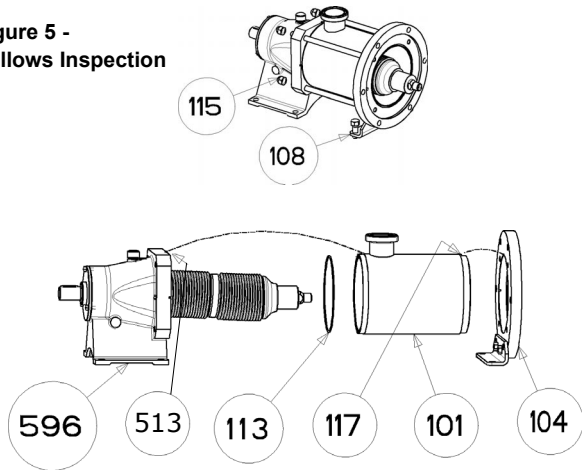

PUMP ASSEMBLY

NOTICE:

FOLLOW ALL HAZARD WARNINGS AND INSTRUCTIONS PROVIDED IN THE “MAINTENANCE” SECTION OF THIS MANUAL.

Torque Settings	C24-I	C36-I
Ref. #106 - Cover plate nuts	100 Nm (74 ft lbs)	100 Nm (74 ft lbs)
Ref. #115 - Bracket nuts	100 Nm (74 ft lbs)	100 Nm (74 ft lbs)
Ref. #304 - Disc nut	250 Nm (184 ft lbs)	250 Nm (184 ft lbs)

Bellows Assembly

Refer to Figure 5 above.

1. Install the seal ring (#113).
2. Install the inlet tube (#101), dowel pins (#117 & #513) are provided for proper alignment. **NOTE: DO NOT STRIKE THE BELLOWS AS DAMAGE CAN OCCUR.**
3. Install bracket (#104) and 4 nuts (#115). Refer to Torque Chart above for proper torque settings.
NOTE: Be sure bolts are correctly positioned. Use standard thread sealant when replacing the 4 nuts (#115).
4. Install the two foot bolts in the bracket (#108).

Cylinder and Disc Assembly

1. Inspect seal rings (#113 and #306). Replace if necessary.
2. Position the seal ring (#113) on the large flange.
3. Position the seal ring (#306) on the hub.
4. Install the cylinder (#201). **NOTE: THE PIN (#118) LOCATED ON THE LARGE FLANGE (#104) MUST FIT INTO THE RECESS ON THE BACK OF THE CYLINDER.**

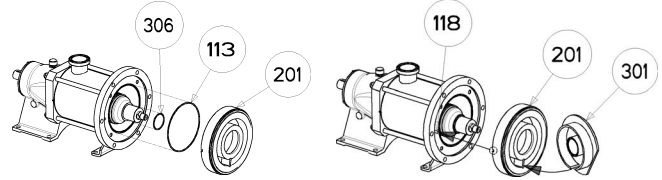

Steps 3 & 4

Steps 5 & 6

5. Fit the disc (#301) to the hub (#596). Align the slot in the disc (#301) with the partition in the cylinder (#201).
6. Exert lateral pressure on the disc (#301) to center it on the cylinder (#201).
7. Insert the disc (#301) into the cylinder (#201).
8. Insure the oblong hole of the disc (#301) engages the two flat surfaces on the end of the hub (#596).

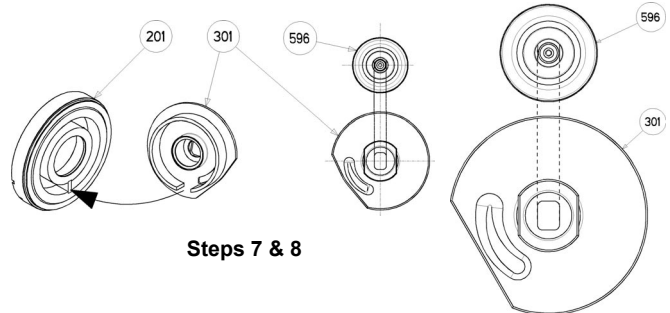

Steps 7 & 8

9. Place thread sealant (Loctite 243 or equivalent) on the hub thread (#596).
10. Install the seal ring (#305).
11. Use a 85 mm wrench to hold the disc (#301) while installing the nut (#304) with its seal ring (#305).

NOTE: DO NOT ROTATE THE DISC AS DAMAGE TO THE BELLOWS CAN OCCUR.

Refer to Torque Chart on page 7 for proper torque settings.

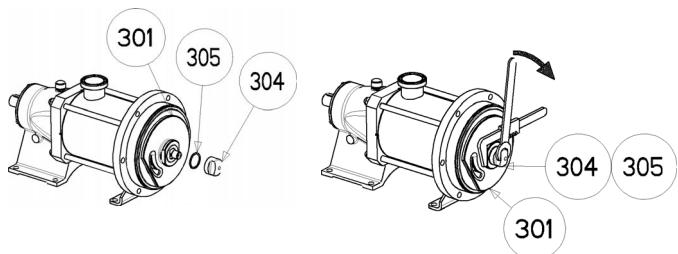

Step 10

Step 11

MAINTENANCE

12. Inspect the 2 seal rings (#205) and replace if necessary.
13. Refit the spacer (#402) with its 2 seal rings (#205).
14. Install the cover plate (#401). Position the 8 bolts (#105 & #107) and install the 8 nuts (#106).

Refer to Torque Chart on page 7 for proper torque settings.

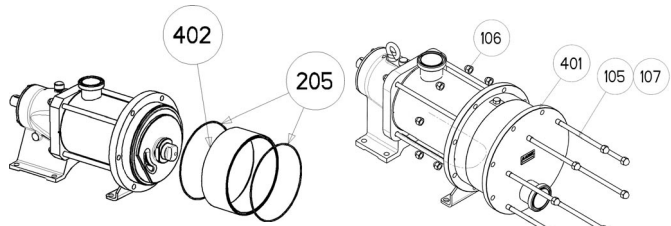

Steps 12 - 13

Step 14

GENERAL PUMP TROUBLESHOOTING

NOTICE:

MAINTENANCE SHALL BE PERFORMED BY QUALIFIED TECHNICIANS ONLY, FOLLOWING THE APPROPRIATE PROCEDURES AND WARNINGS AS PRESENTED IN THIS MANUAL.

SYMPTOM	POSSIBLE CAUSE
Reduced Capacity	<ol style="list-style-type: none"> 1. Pump speed too low. 2. Suction valves not fully open. 3. Air leaks in the suction line. 4. Excessive restriction in the suction line (i.e.: undersized piping, too many elbows & fittings, clogged strainer, etc.). 5. Damaged or excessively worn parts. 6. Excessive restriction in discharge line causing partial flow through the external bypass valve system. 7. Viscosity exceeds rating of pump.
Noise	<ol style="list-style-type: none"> 1. Excessive vacuum on the pump due to: <ol style="list-style-type: none"> a. Undersized or restricted fittings in the suction line. b. Pump speed too fast for the viscosity or volatility of the liquid. c. Pump too far from fluid source. 2. Pump not securely mounted. 3. Bearings worn or damaged. 4. Vibration from improperly anchored piping. 5. Bent shaft, or drive coupling misaligned. 6. Excessively worn disc and cylinder. 7. Malfunctioning valve in the system. 8. Running the pump dry for more than five (5) minutes.
Damaged Disc or Cylinder	<ol style="list-style-type: none"> 1. Foreign objects entering the pump. 2. Running the pump dry for more than five (5) minutes. 3. Cavitation. 4. Incompatibility with the liquids pumped. 5. Excessive heat. 6. Settled or solidified material in the pump at start-up. 7. Hydraulic hammer - pressure spikes.



1809 Century Avenue, Grand Rapids, Michigan 49503-1530, U.S.A.
 Telephone: (616) 241-1611 / Fax: (616)-241-3752
 E-Mail: blackmer@blackmer.com / Internet: www.blackmer.com