

Telephone 800-500-9311  
Telephone 864-573-9200  
Fax 864-573-9299

# OEC FLUID HANDLING INC.

SUBSIDIARY OF OILMEN'S EQUIPMENT CORP.  
[www.oecfh.com](http://www.oecfh.com)

140 Cedar Springs Rd.  
P. O. Box 2807  
Spartanburg, SC 29304

■ Stocked Items 11/06/03

## PD Pumps

- ARO Ingersoll-Rand
- Blackmer Vane  
Blackmer/Abaque Peristaltic  
Blackmer "C" Eccentric Disc
- Alfa Laval-TriClover Lobe
- APV Lobe
- Tuthill Gear  
Tuthill Lobe  
MonoFlo Progressive Cavity

## Centrifugal Pumps

- Alfa Laval-TriClover Sanitary
- APV Crepaco
- Deming End Suction  
Deming Vertical Turbine
- Griswold ANSI Pumps
- MP Pump

## Specialty Pumps

Flux Drum

## Petroleum-Fuel Pumps

- Gorman-Rupp
- Dresser Wayne Corp
- Red Jacket  
Graco  
William Wilson Gasboy

## Hand Pumps

- Blackmer
- Tokhiem
- Tuthill Fill-Rite

## Storage Tanks

Stainless Steel ASME  
UL & ASME Carbon Steel  
Fiberglass Tanks  
Chem-Tainer Poly Tanks  
Assmann Poly Tanks  
Snyder Poly Tanks

## Tank Fittings & Vents

- OPW Engineered Systems  
EMCO Wheaton  
Morrison Bros  
Protectoseal

## Mechanical Seals

Utex



## Meters & Instrumentation

- Micro Motion Coriolis
- Neptune Actaris PD
- Tuthill FPP PD
- Liquid Controls PD  
Halliburton Turbine  
Rosemount  
Pressure Transmitters  
Flow Transmitters  
Temperature Transmitters  
Level Transmitters

## Sanitary Products

- Alfa Laval-TriClover Pumps
- Alfa Laval-TriClover Fittings  
Alfa Laval-TriClover Valves  
APV Pumps  
APV Valves  
APV Homogenizers  
B & A Flexible Sanitary Hose

## Liquid Level Gauges

- Protectoseal  
Pneumercator  
Moorman Bros  
Milltronics/Siemens  
Rosemount Level Transmitters

## Hose & Reels

- Goodyear Hose
- Hannay Reels  
Lawrence Composite Hose

## Filters

Filtration Group Bag Filters

## Mixers

Brawn Portable & Sanitary  
Proquip Top Entry Agitators

## Liquid Loaders & Platforms

OPW Engineered Systems  
Green Manufacturing

## Rotary Unions

Deublin

## Custom Liquid Systems

For liquid transfer, batching &  
process metering

**Performance Guaranteed**

CHARLOTTE, NC ■ SPARTANBURG, SC ■ GREENSBORO, NC

# BLACKMER PARTS LIST

960268      **PARTS LIST**  
Page 1 of 4      **109-D00**

## With Installation and Maintenance Instructions HELICAL GEAR REDUCERS MODEL: HRC

Section | 109  
Effective | June 2006  
Replaces | July 2002



### This is a SAFETY ALERT SYMBOL.

When you see this symbol on the product, or in the manual, look for one of the following signal words and be alert to the potential for personal injury, death or major property damage



Warns of hazards that **WILL** cause serious personal injury, death or major property damage.



Warns of hazards that **CAN** cause serious personal injury, death or major property damage.



Warns of hazards that **CAN** cause personal injury or property damage.

### NOTICE:

Indicates special instructions which are very important and must be followed.

### NOTICE:

Blackmer gear reducers **MUST** only be installed in systems, which have been designed by qualified engineering personnel. The system **MUST** conform to all applicable local and national regulations and safety standards.

These instructions are intended to assist in the installation of and maintenance of the Blackmer gear reducer, and **MUST** be kept with the reducer.

Blackmer gear reducer service shall be performed by qualified technicians **ONLY**. Service shall conform to all applicable local and national regulations and safety standards.

Thoroughly review this manual, all instructions and hazard warnings, **BEFORE** performing any work on Blackmer gear reducer.

Maintain **ALL** system and Blackmer pump and reducer operation and hazard warning decals.

### NOTICE:

**Pump manuals, parts lists and other needed literature may be obtained from the Blackmer website ([www.blackmer.com](http://www.blackmer.com)) or by contacting Blackmer Customer Service.**

### WARNING



Hazardous voltage.  
Can shock, burn or cause death.

**Failure to disconnect and lockout electrical power before attempting maintenance can cause shock, burns or death**

### WARNING



Hazardous or toxic fluids can cause serious injury.

**If pumping hazardous or toxic fluids, system must be flushed and decontaminated, inside and out, prior to performing service or maintenance**

### WARNING



Hazardous pressure can cause personal injury or property damage

**Disconnecting fluid or pressure containment components during pump operation can cause serious personal injury, death or major property damage**

### WARNING



Hazardous machinery can cause serious personal injury.

**Failure to disconnect and lockout electrical power or engine drive before attempting maintenance can cause severe personal injury or death.**

### WARNING



Hazardous pressure can cause severe personal injury or property damage

**Failure to relieve system pressure prior to performing pump service or maintenance can cause severe personal injury or property damage.**

### CAUTION



Extreme heat can cause injury or property damage.

**Failure to allow gear reducer to cool before attempting maintenance can cause serious personal injury.**

**NOTE:** Numbers in parentheses following individual parts indicate reference numbers on the corresponding Lip Seal Parts Lists.

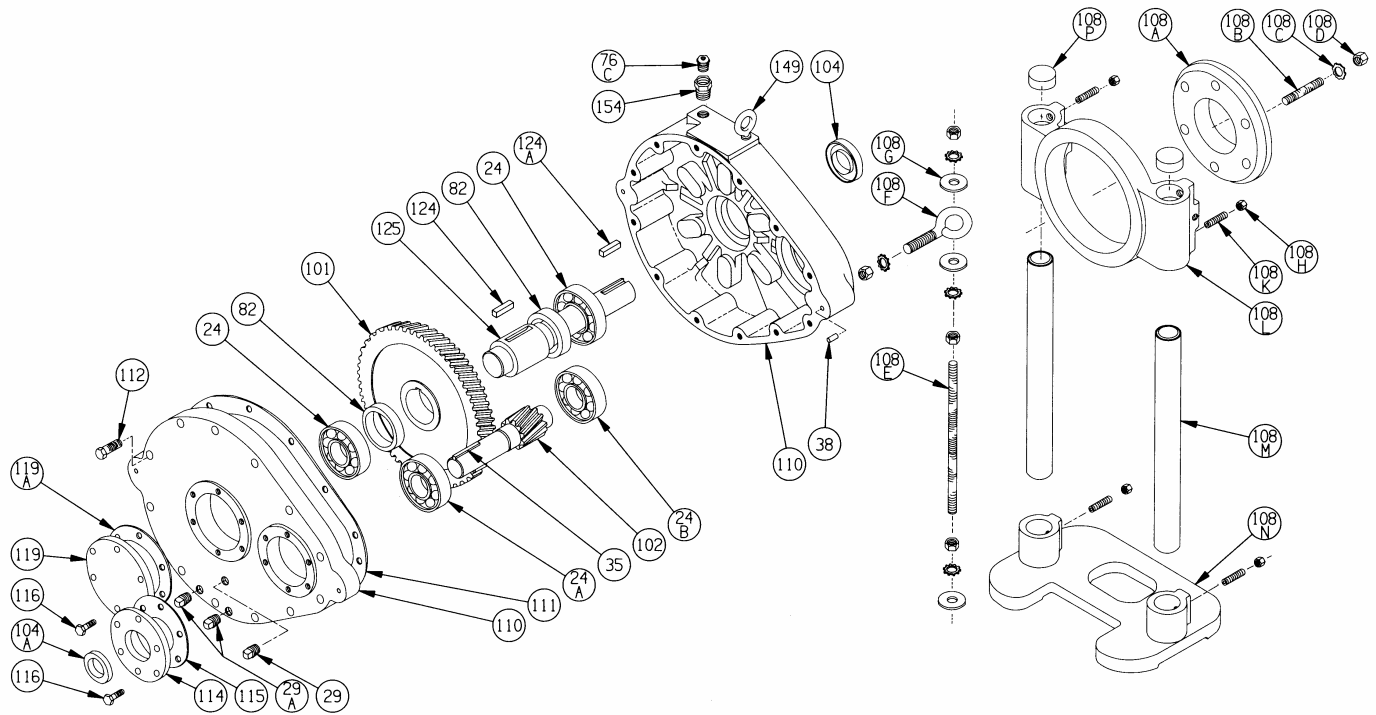

Ref. No.	Description	Parts per Unit	Part No.	Ref. No.	Description	Parts per Unit	Part No.
24	Bearing – Shielded	2	903172	119A	Gasket – Blind Closure Plate	1	814022
24A	Bearing	1	903179	124	Key – Gear	1	909180
24B	Bearing	1	903178	124A	Key – Shaft	1	909182
29	Oil Level Plug	1	908198	125	Shaft	1	704030
29A	Drain Plug	2	908100	149	Eyebolt	1	922450
35	Key – Pinion	1	909177	154	Bushing	1	908794
38	Dowel Pin	2	930739		<b>BRACKET ASSEMBLY</b>		871085
76C	Fill & Vent Plug	1	701988	108A	Bracket Ring	1	834018
82	Spacer Ring	2	374021	108B	Bracket Stud	6	921534
101	Gear	1	See Table	108C	Lockwasher	10	909630
102	Pinion & Shaft	1	See Table	108D	Nut (1/2 – 13)	10	922850
104	Oil Seal	1	331907	108E	Torque Arm (Stud)	1	921584
104A	Oil Seal	1	331909	108F	Eyebolt	1	922474
110	Gearbox Assembly <sup>1</sup>	1	894021	108G	Plain Washer (1/2")	3	909670
111	Gasket – Cover	1	814020	108H	Nut (3/8 – 24)	6	922843
112	Capscrews – Cover	14	920381	108K	Setscrew	6	922204
114	Closure Plate – Input	1	*	108L	Mounting Bracket	1	834031
115	Gasket – Input Closure Plate	1	814021	108M	Slider Post	2	834030
116	Capscrews – Closure Plate	12	920073	108N	Foot	1	834028
119	Closure Plate – Blind	1	*	108P	Pipe Cap	2	344001

\* Non-saleable item – included with Gearbox Assembly. <sup>1</sup> Gearbox Assembly includes Ref. Nos. 38, 110, 111, 112, 114, 115, 116, 119, 119A. Keep this parts list with Installation, Operation and Maintenance Instructions.

**GEAR AND PINION SELECTION TABLE**

RATIO	RPM	102 PINION NO.	QTY.	101 GEAR NO.	QTY.
5.69	300	915145	1	919945	1
7.70	230	915146	1	919946	1
9.08	190	915147	1	919947	1

**NOTE:** Speed is based on 1750 rpm input.

# INSTALLATION

## NOTICE

This product must only be installed in systems which have been designed by those qualified to engineer such systems. The system must be in accordance with all applicable regulations and safety codes and warn of any hazards unique to the particular system.

## ALIGNMENT ADJUSTMENT

The gear reducer can be moved vertically on its bracket mount to raise or lower the output shaft (slow speed shaft) to align with the pump shaft.

The reducer can also be rotated on the bracket ring to facilitate both horizontal and vertical alignment of the input shaft (high speed shaft) to the motor shaft. This flexibility in movement eliminates the need for shims under the motor or driver in most cases. NOTE: Refer to Blackmer Dimensions 109-104 for maximum variation of shaft alignment to maintain proper gear reducer lubrication.

Follow these steps to align the reducer:

1. Align the output shaft to the pump shaft by loosening the four (4) setscrews (108K) and locknuts in the mounting bracket (108L), enabling the reducer to slide freely on the slider posts.
2. Once the proper alignment is determined, retighten the setscrews and locknuts. Leave the torque arm locknuts loosened for the next step.
3. Align the input shaft to the motor shaft by loosening the four (4) bracket nuts (108D) in the bracket ring (108A)

- enabling the reducer to rotate freely. If the reducer sticks on the mounting bracket, tap it lightly with a mallet.
4. After obtaining the correct alignment, be sure to retighten the bracket nuts and the upper and lower locknuts of the torque arm.

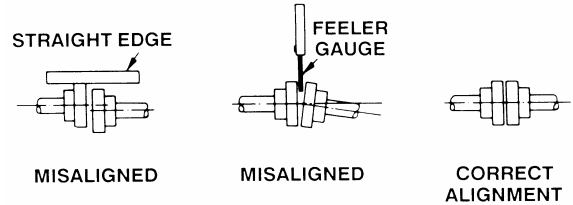

Figure 1 - Alignment Check

## COUPLING ALIGNMENT

Both angular and parallel coupling alignment MUST be maintained between the pump, gear, motor, etc. in accordance with manufacturer's instructions. See figure 1.

1. Parallel alignment: The use of a laser alignment tool or dial indicator is preferred. If a laser alignment tool or dial indicator is not available, use a straightedge. Turn both shafts by hand, checking the reading through one complete revolution. Maximum offset must be less than .005" (125 microns).
2. Angular alignment: Insert a feeler gauge between the coupling halves. Check the spacing at 90° increments around the coupling (four check points). Maximum variation must not exceed .005" (125 microns). Some laser alignment tools will check angular alignment as well.
3. Replace the coupling guards after setting alignment.

# MAINTENANCE

## NOTICE:

Maintenance and troubleshooting must be done by an individual experienced with pump and reducer maintenance and the type of system involved.

## NOTICE:

To avoid possible entanglement in moving parts do not lubricate pump bearings, gear reducer or any other parts while the pump is running.

**CAUTION:** The normal full load operating temperature of the gearcase is 180°F (82°C) – too hot to touch with the bare hand.

## LUBRICATION

**Gear reducers are not lubricated at the factory. Oil MUST be added before starting the pump.**

Horsepower calculations for Blackmer reducers are based on 75°F (24°C) ambient air temperature; 200°F (93°C) maximum oil temperature using synthetic oil.

Blackmer recommends using synthetic oil with oxidation inhibitors and is compatible with Buna elastomers. Use synthetic oil AGMA Viscosity Grade 4 or ISO Viscosity Grade 150 such as Mobil SHC 629, Shell Omala 150 HD, Castrol Isolube EP 150 or equivalent.

**To add oil to the gear reducer:**

1. Remove the oil level plug (29) and the fill and vent plug (76C). **NOTE:** The vent fitting in the fill plug (76C) should be kept clean to prevent expansion from forcing oil leaks at the shaft.

2. Add oil through the filler hole until oil runs out of the oil level hole – approximately 2.25 qt. (2.13 l) depending on the orientation of the reducer mounting.
3. Replace the oil level plug and the fill and vent plug.
4. After the first two weeks of operation, the oil should be drained, the gearcase flushed, and new oil added.

For normal operation, the oil should be changed every six months or 1000 hours, whichever is shorter. If operation is accompanied by frequent and wide changes in temperature, or if the unit operates in an unusually moist or dusty atmosphere, the oil should be changed every 500 hours or every three months. **NOTE:** To maintain proper gear reducer lubrication, refer to Blackmer Dimensions 109-104 for maximum variation of shaft alignment.

## REDUCER DISASSEMBLY

The gearcase on the bracket mounted gear reducer can usually be removed from its bracket without disturbing the motor or pump mounting.

1. Take apart the couplings and remove the six bracket nuts (108D) and lockwashers (108C) from the bracket ring. Also remove the upper locknut and lockwasher from the torque arm (108E).
2. Once the bracket nuts are removed, rotate the gearcase on the bracket and swing the input shaft away from the motor.
3. The gear reducer can then be lifted off the pump with the bracket ring and studs still intact.
4. Remove the twelve hex-head cover capscrews (112). **NOTE:** The gearcase cover is located on the gearcase with two dowel pins (38). These pins remain in the gearcase.

5. After the capscrews have been removed, insert a wedge between the projecting lugs on the gearcase cover and tap lightly until the cover loosens and can be removed from the casing.
  6. Remove the cover gasket (111).
  7. The pinion & shaft (input shaft) (102) is a one-piece assembly and does not come apart. If necessary, the bearings (24A & 24B) can be removed from the shaft with the use of a bearing puller or arbor press.
  8. To remove the gear (101) and bearings (24) from the output shaft (125), use a gear puller or arbor press. Support the assembly on the gear and press the shaft out of the gear and one bearing only. The second bearing must come off in the other direction because of the shoulder on the shaft.
- c. Press the short end of the shaft (125) squarely into the bearing (24). The shield of the bearing should face downward with the balls of the bearing facing the gear.
  - d. Install a spacer ring (82).
  - e. Align the gear key (124) with the notch in the gear, and press the gear (101) squarely onto the shaft.
  - f. Add a spacer ring (82) and press the second bearing (24) onto the shaft with the shield upward so that the balls of the bearing face the gear.
2. To assemble the input shaft (102) (Pinion & Shaft):
    - a. Follow steps 1a and 1b Prior to installing the bearings.
    - b. Press the large bearing (24A) onto the driven-end of the pinion & shaft.
    - c. Press the small bearing (24B) onto the non-driven end of the pinion & shaft.

### OIL SEAL REPLACEMENT

1. To replace the oil seal (104A) on the **input shaft**, it is only necessary to remove the closure plate (114). Once the plate is removed, the old seal can be pressed out and a new one installed. Grease the lip of the oil seal before installing. The oil seal must be inserted such that the lip of the seal will face inward when the closure plate is reattached to the gearcase cover.
  2. To replace the oil seal (104A) on the **input shaft**, it is only necessary to remove the closure plate (114). Once the plate is removed, the old seal can be pressed out and a new one installed. Grease the lip of the oil seal before installing. The oil seal must be inserted such that the lip of the seal will face inward when the closure plate is reattached to the gearcase cover.
3. After the shafts, gears and bearings have been assembled, apply a light film of oil in the bearing bores of the gearcase to help the bearings slide into position.
  4. If the oil seal (104) has been removed from the gearcase, it must be replaced prior to reassembly. Refer to step 2 of "Oil Seal Replacement."
  5. To install the shaft assemblies into the gearcase it is easiest to tip the gearcase so that it is resting on the bracket studs with the cavity opening upward.
    - a. Start the output shaft (125) into the bearing bore of the gearcase.
    - b. Align the bearings and gear teeth of the input shaft (102) with the output shaft and drop the two shaft assemblies together into their respective bearing bores. **NOTE:** It is important to line the bearings up squarely with the bores in order for them to drop smoothly into place. If the bearings are positioned correctly in the gearcase, the shafts should rotate freely when turned by hand.
  6. Once the input and output shaft assemblies are properly installed, set the cover gasket (111) on the gearcase.
  7. Position the cover on the gearcase using the dowel pins for alignment.
  8. Install and tighten the cover capscrews (112).
  9. Make sure the oil seal (104A) is inserted in the closure plate (114) before reattaching the plate to the gearcase cover. Refer to step 1 of "Oil Seal Replacement."
  10. Attach the input closure plate gasket (115) and the closure plate (114) to the gearcase cover.

### REDUCER ASSEMBLY

Before reassembling the gear reducer, clean each part thoroughly. Wash out the bearing bores and remove all burrs or sharp corners with a file.

**NOTE:** Disregard steps 1 and 2 if the shaft and bearing assemblies have not been dismantled.

1. The output shaft (125) has a stepped shoulder where the gear must be located.
  - a. Before installing the gear and bearings, remove all dirt, burrs, or sharp corners from the shaft to prevent galling or seizing of the gear and shaft.
  - b. Apply a coat of graphite, molysulphide, or white lead to the shaft.

## TROUBLESHOOTING

### NOISE AND VIBRATION

#### POSSIBLE CAUSES:

1. Worn or damaged bearings.
2. Inadequate lubrication / use of wrong lubricant.
3. Impurities in the lubricant, such as abrasive particles.
4. Excessive overloading.
5. Misalignment to either pump or motor.

#### REMEDY:

- Replace bearings.
- Check oil condition. The lubricant may not be getting to the contact areas of the gear teeth, or the viscosity of the oil may be too low for the operating temperature (see "Lubrication").
- Replace with clean oil (see "Lubrication")
- Overloading causes overheating which may lower oil viscosity and thus cause the oil film on gear teeth contact surfaces to break down. The gears will begin to "groan" as the oil loses its effectiveness. If the loading is not decreased, the gear teeth will begin to "bite" into each other and wear out rapidly.
- Recheck alignment and adjust as necessary.

