

Telephone 800-500-9311
Telephone 864-573-9200
Fax 864-573-9299

OEC FLUID HANDLING INC.

SUBSIDIARY OF OILMEN'S EQUIPMENT CORP.
www.oecfh.com

140 Cedar Springs Rd.
P. O. Box 2807
Spartanburg, SC 29304

■ Stocked Items 11/06/03

PD Pumps

- ARO Ingersoll-Rand
- Blackmer Vane
Blackmer/Abaque Peristaltic
Blackmer "C" Eccentric Disc
- Alfa Laval-TriClover Lobe
- APV Lobe
- Tuthill Gear
Tuthill Lobe
MonoFlo Progressive Cavity

Centrifugal Pumps

- Alfa Laval-TriClover Sanitary
- APV Crepaco
- Deming End Suction
Deming Vertical Turbine
- Griswold ANSI Pumps
- MP Pump

Specialty Pumps

Flux Drum

Petroleum-Fuel Pumps

- Gorman-Rupp
- Dresser Wayne Corp
- Red Jacket
Graco
William Wilson Gasboy

Hand Pumps

- Blackmer
- Tokhiem
- Tuthill Fill-Rite

Storage Tanks

Stainless Steel ASME
UL & ASME Carbon Steel
Fiberglass Tanks
Chem-Tainer Poly Tanks
Assmann Poly Tanks
Snyder Poly Tanks

Tank Fittings & Vents

- OPW Engineered Systems
EMCO Wheaton
Morrison Bros
Protectoseal

Mechanical Seals

Utex

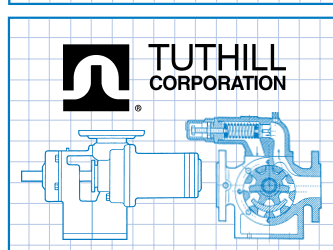
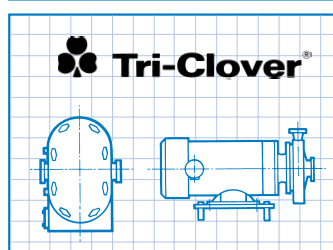
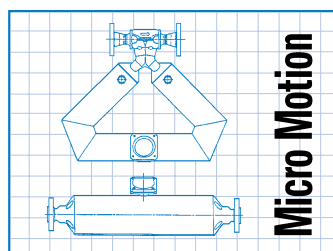
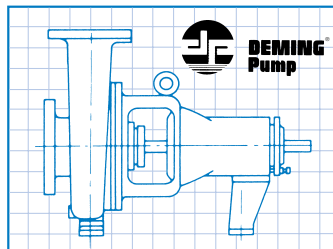
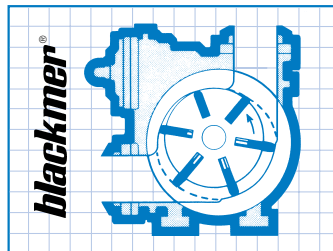
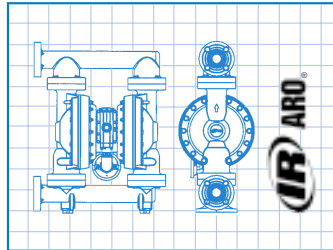

Meters & Instrumentation

- Micro Motion Coriolis
- Neptune Actaris PD
- Tuthill FPP PD
- Liquid Controls PD
Halliburton Turbine
Rosemount
Pressure Transmitters
Flow Transmitters
Temperature Transmitters
Level Transmitters

Sanitary Products

- Alfa Laval-TriClover Pumps
- Alfa Laval-TriClover Fittings
Alfa Laval-TriClover Valves
APV Pumps
APV Valves
APV Homogenizers
B & A Flexible Sanitary Hose

Liquid Level Gauges

- Protectoseal
Pneumercator
Moorman Bros
Milltronics/Siemens
Rosemount Level Transmitters

Hose & Reels

- Goodyear Hose
- Hannay Reels
Lawrence Composite Hose

Filters

Filtration Group Bag Filters

Mixers

Brawn Portable & Sanitary
Proquip Top Entry Agitators

Liquid Loaders & Platforms

OPW Engineered Systems
Green Manufacturing

Rotary Unions

Deublin

Custom Liquid Systems

For liquid transfer, batching &
process metering

Performance Guaranteed

CHARLOTTE, NC ■ SPARTANBURG, SC ■ GREENSBORO, NC

BLACKMER POWER PUMPS

960255

INSTRUCTIONS NO. 104-A00

INSTALLATION OPERATION AND MAINTENANCE INSTRUCTIONS

Section	104
Effective	March 2007
Replaces	June 2006

**MODELS: SNP1.25, SNP1.5, SNP2, SNP2.5, SNP3A
SNPJ1.25, SNPJ1.5, SNPJ2, SNPJ2.5**

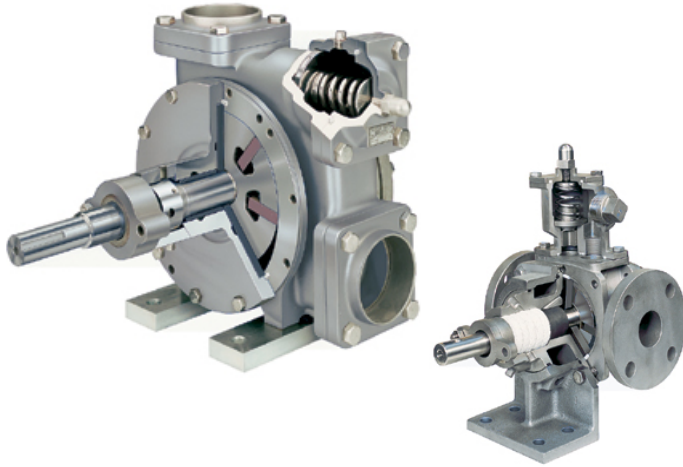

SAFETY DATA



This is a SAFETY ALERT SYMBOL.

When you see this symbol on the product, or in the manual, look for one of the following signal words and be alert to the potential for personal injury, death or major property damage



Warns of hazards that **WILL** cause serious personal injury, death or major property damage.



Warns of hazards that **CAN** cause serious personal injury, death or major property damage.



Warns of hazards that **CAN** cause personal injury or property damage.

NOTICE:

Indicates special instructions which are very important and must be followed.

TABLE OF CONTENTS

Page

PUMP DATA

Technical Data	2
Initial Pump Start Up Information.....	2

INSTALLATION

Pre-Installation Cleaning	3
Location and Piping.....	3
Pump Mounting	4
Coupling Alignment	4
Pump Rotation.....	4
To Change Pump Rotation	4
Check Valves	4
Jacketed Heads.....	4

OPERATION

Pre-Start Up Check List.....	5
Start Up Procedures.....	5
Running the Pump in Reverse Rotation	6
Flushing the Pump	6
Pump Relief Valve.....	7
Relief Valve Setting and Adjustment	7

MAINTENANCE

Strainers.....	8
Lubrication.....	8
Vane Replacement.....	8
Pump Disassembly	9
Parts Replacement.....	9
Pump Assembly	11

TROUBLE SHOOTING 13

NOTE: Numbers in parentheses following individual parts indicate reference numbers on Blackmer Parts List No. 104-A01, 104-A02, 104-A03 and 104-A04.

Blackmer pump manuals and parts lists may be obtained from Blackmer's website (www.blackmer.com) or by contacting Blackmer Customer Service.

NOTICE:

Blackmer Pumps **MUST** only be installed in systems, which have been designed by qualified engineering personnel. The system **MUST** conform to all applicable local and national regulations and safety standards.

This manual is intended to assist in the installation and operation of the Blackmer SNP / SNPJ Series pumps, and **MUST** be kept with the pump.

Pump service shall be performed by qualified technicians **ONLY**. Service shall conform to all applicable local and national regulations and safety standards.

Thoroughly review this manual, all instructions and hazard warnings, **BEFORE** performing any work on the pump.

Maintain **ALL** system and pump operation and hazard warning decals.

SAFETY DATA

⚠ WARNING



Hazardous machinery can cause serious personal injury.

Failure to disconnect and lockout electrical power or engine drive before attempting maintenance can cause severe personal injury or death

⚠ WARNING



Hazardous voltage. Can shock, burn or cause death.

Failure to disconnect and lockout electrical power before attempting maintenance can cause shock, burns or death

⚠ WARNING



Hazardous machinery can cause serious personal injury.

Failure to stop the pump before adjusting the shaft packing can cause severe personal injury.

⚠ WARNING



Hazardous pressure can cause personal injury or property damage

Disconnecting fluid or pressure containment components during pump operation can cause serious personal injury, death or major property damage

⚠ WARNING



Hazardous or toxic fluids can cause serious injury.

If pumping hazardous or toxic fluids, system must be flushed and decontaminated, inside and out, prior to performing service or maintenance

⚠ WARNING



Hazardous pressure can cause personal injury or property damage

Failure to relieve system pressure prior to performing pump service or maintenance can cause personal injury or property damage.

⚠ WARNING



Do not operate without guard in place

Operation without guards in place can cause serious personal injury, major property damage, or death.

PUMP DATA

PUMP IDENTIFICATION

A pump Identification tag, containing the pump serial number, I.D. number, and model designation, is attached to each pump. It is recommended that the data from this tag be recorded and filed for future reference. If replacement parts are needed, or if information pertaining to the pump is required, this data must be furnished to a Blackmer representative.

TECHNICAL DATA *

	SNP(J)1.25 SNP(J)1.5	SNP(J)2 SNP(J)2.5 SNP3A
Maximum Pump Speed	1800 RPM	640 RPM
Maximum Operating Temperature	240°F (115°C)	240°F (115°C)
Maximum Viscosity	20,000 SSU (4,250 cSt)	20,000 SSU (4,250 cSt)
Maximum Differential Pressure	150 psi (10.3 Bar)	150 psi (10.3 Bar)
Maximum Working Pressure	175 psi (12.1 Bar)	175 psi (12.1 Bar)
Maximum Jacket Pressure	150 psi (10.3 Bar)	150 psi (10.3 Bar)

INITIAL PUMP START UP INFORMATION

Model No.:	_____
Serial No.:	_____
ID No.:	_____
Date of Installation:	_____
Inlet Gauge Reading:	_____
Discharge Gauge Reading:	_____
Flow Rate:	_____

* Technical Data is for standard materials of construction. Consult Blackmer Material Specs for optional materials of construction.

INSTALLATION

NOTICE:

Blackmer pumps must only be installed in systems designed by qualified engineering personnel. System design must conform with all applicable regulations and codes and provide warning of all system hazards.

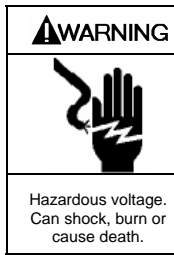

- ⚠ Install, ground and wire to local and National Electrical Code requirements.
- ⚠ Install an all-leg disconnect switch near the unit motor.
- ⚠ Disconnect and lockout electrical power before installation or service
- ⚠ Electrical supply **MUST** match motor nameplate specifications.

⚠ Motors equipped with thermal protection automatically disconnect motor electrical circuit when overload exists. Motor can start unexpectedly and without warning.

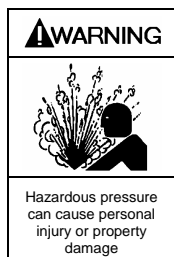

An external bypass valve and/or internal relief valve **must** be installed in the system to protect the pump from excessive pressure.



Incorrect bypass valve or internal relief valve settings can cause pump component failure, personal injury, and property damage.

NOTICE:

Blackmer SNP Pump sizes 1.25, 1.5, 2 and 2.5 may or may not be fitted with an bolt-on relief valve. If the bolt-on relief valve is not supplied, an external bypass valve **MUST** be used.

PRE-INSTALLATION CLEANING

NOTICE:

New pumps contain residual test fluid and rust inhibitor. If necessary, flush pump prior to use.

Foreign matter entering the pump **WILL** cause extensive damage. The supply tank and intake piping **MUST** be cleaned and flushed prior to pump installation and operation.

LOCATION AND PIPING

Pump life and performance can be significantly reduced when installed in an improperly designed system. Before starting the layout and installation of the piping system, review the following suggestions:

1. Locate the pump as near as possible to the source of supply to avoid excessive inlet pipe friction.
2. The inlet line must be at least as large as the intake port on the pump. Slope the piping downward to the pump, without any upward loops. Eliminate restrictions such as sharp bends; globe valves, unnecessary elbows, and undersized strainers.
3. Install a system bypass valve that returns excess flow to the supply tank or pump inlet piping as appropriate for the pumping system. Insure that the bypass valve pressure setting is appropriate for the pump and system component working pressures.
4. It is recommended a strainer be installed in the inlet line to protect the pump from foreign matter. Locate the strainer at least 24" (0.6m) from the pump, and have a net open area of at least four times the area of the intake piping. Strainers must be cleaned regularly to avoid pump starvation.
5. The intake system must be free of air leaks.
6. Expansion joints, placed at least 36" (0.9m) from the pump, will compensate for expansion and contraction of the pipes. Contact the flexible connector/hose manufacturer for required maintenance/care and design assistance in their use.
7. Install pressure gauges in the NPT ports provided in the pump casing to check pump at start up.
7. ALL piping and fittings **MUST** be properly supported to prevent any piping loads from being placed on the pump.
8. Check alignment of pipes to pump to avoid strains which might later cause misalignment. See Figure 1. Unbolt flanges or break union joints. Pipes should not spring away or drop down. After pump has been in operation for a week or two, completely recheck alignment.

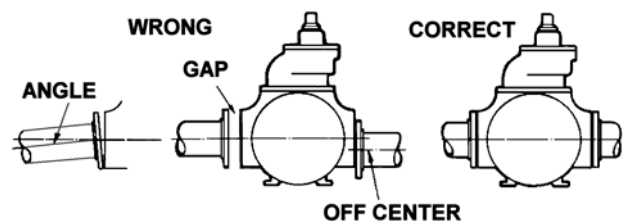

Figure 1

9. When pumping liquids at elevated temperature, make provisions to compensate for expansion and contraction of the pipes, especially when long pipe lines are necessary. Steel pipe expands approximately 3/4" (1.9 cm) per 100 feet (30.49 m) per 100°F (37.8°C) rise in temperature.

INSTALLATION

PUMP MOUNTING

A solid foundation reduces noise and vibration, and will improve pump performance. On permanent installations it is recommended the pumping unit be secured by anchor bolts as shown in Figure 2. This arrangement allows for slight shifting of position to accommodate alignment with the mounting holes in the base plate.

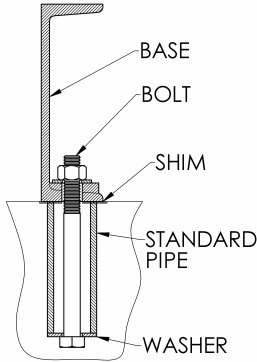

Figure 2 - Pipe Type Anchor Bolt Box

For new foundations, it is suggested that the anchor bolts be set in concrete. When pumps are to be located on existing concrete floors, drill holes into the concrete to hold the anchor bolts.

When installing units built on channel or structural steel type bases, use care to avoid twisting the base out of shape when anchor bolts are tightened. Use shims under the edges of the base prior to tightening the anchor bolts to level the base and prevent distortion.

COUPLING ALIGNMENT

The pump must be directly coupled to a gear and/or driver with a flexible coupling. Both angular and parallel coupling alignment **MUST** be maintained between the pump, gear, motor, etc. in accordance with manufacturer's instructions. See Figure 3.

1. Parallel alignment: The use of a laser alignment tool or dial indicator is preferred. If a laser alignment tool or dial indicator is not available, use a straightedge. Turn both shafts by hand, checking the reading through one complete revolution. Maximum offset must be less than .005" (.127 mm).
2. Angular alignment: Insert a feeler gauge between the coupling halves. Check the spacing at 90° increments around the coupling (four checkpoints). Maximum variation must not exceed .005" (.127 mm). Some laser alignment tools will check angular alignment as well.
3. Replace the coupling guards after setting alignment.

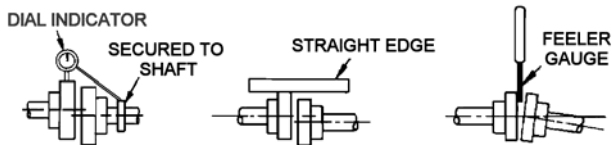
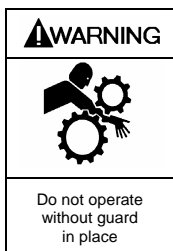

Figure 3 – Alignment Check



Operation without guards in place can cause serious personal injury, major property damage, or death.

Do not operate without guard in place

PUMP ROTATION

NOTICE:

Confirm correct pump rotation by checking the pump rotation arrows respective to piping flow direction. Do not operate the pump in reverse rotation to reverse the direction of flow.

1. Determine direction of flow where the pump will be installed.
2. Confirm pump is installed in piping so that the flow will pass through the pump from inlet to outlet. The inlet of the pump has "INLET" cast in the cylinder and the outlet has "OUTLET" cast in the cylinder.
3. Briefly "jog" pump with pump driver. Check rotation of pump driver with respect to rotation arrow on pump.

A right-hand pump rotates clockwise with the intake on the right side, when viewed from the driven end.

A left-hand pump rotates counterclockwise with the intake on the left side, when viewed from the driven end.

TO CHANGE PUMP ROTATION

To reverse rotation, the pump must be disassembled then reassembled with the shaft on the opposite side of the pump. See the 'Maintenance' section for instructions.

CHECK VALVES

The use of check valves or foot valves in the supply tank is not recommended with self-priming, positive displacement pumps.

If the possibility of liquid backflow exists when the pump is off, a check valve in the pump discharge piping is recommended because the pump can motor in the reverse rotation and create undue stress on all attached components. Never start a pump when it is rotating in the reverse rotation as the added starting torque can damage the pump and related equipment. If a check valve is used, install it at the pump discharge.

OPTIONAL JACKETED HEADS

Hot oil or steam can be circulated through jacketed heads by connections at the 1/2" NPT pipe plugs directly above and below the shaft for heating highly viscous liquids, or to "thaw out" liquids which have congealed in the pumping chamber and packing area. Refer to the 'Technical Data' table on page 2 for the maximum allowable steam pressure.

Make sure heat is applied early enough to sufficiently thin the liquid before starting the pump. Liquids that congeal in the relief valve chamber will make the valve inoperative. Insulation of the pump with sufficient heat to the jackets will usually thin the liquid in the relief valve chamber. Take precautions to ensure the valve has free movement. It is advisable to start the pump with an open discharge.

Drain the pump of all water when there is a possibility of freezing. On models which have the steam connections on the vertical center line, make the lower connection the outlet so the water can be drained off. Models which have the steam connections on the side also have a bottom drain plug.

OPERATION

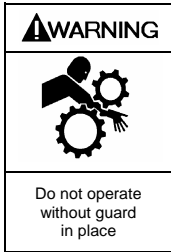

Operation without guards in place can cause serious personal injury, major property damage, or death.



Disconnecting fluid or pressure containment components during pump operation can cause serious personal injury, death or major property damage

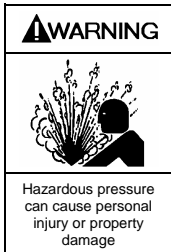

Failure to relieve system pressure prior to performing pump service or maintenance can cause personal injury or property damage.

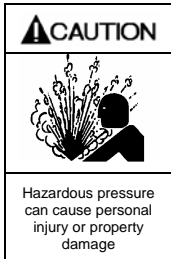

Pumps operating against a closed valve can cause system failure, personal injury and property damage

PRE-START UP CHECK LIST

1. Check the alignment of the pipes to the pump. Support pipes so that they do not spring away or drop down when pump flanges or union joints are disconnected.
2. Blackmer helical gear reducers (if supplied) are shipped from the factory without oil in the gearcase. Fill with the grade of oil indicated on the reducer tag. For more specific instructions on Blackmer gear reducers, refer to the appropriate Gear reducer Installation, Operation and Instruction Manual.
3. Check the entire pumping system to verify that the proper inlet and discharge valves are fully open, and that the drain valves and other auxiliary valves are closed.
4. Install vacuum and pressure gauges on the pump in the 1/4" NPT connections provided. These can be used to check actual suction and discharge conditions after pump start-up.
5. Check the wiring of the motor, and briefly turn on the power to make sure that the pump rotates in the direction of the rotation arrow.

START UP PROCEDURES

NOTICE:

Consult the "general pump troubleshooting" section of this manual if difficulties during start up are experienced.

1. Start the motor. Priming should occur within one minute.
2. Check the vacuum and pressure gauges to see if the pump is operating within the expected conditions.
3. Check for leakage from the piping and equipment.
4. Check for overheating, excessive noise or vibration of the pump, reducer, and motor.
5. Check the flow rate to ensure the pump is operating within the expected parameters. Record flow rate in the "initial Start Up Information" section.
6. Check the pressure setting of the relief valve by briefly closing a valve in the discharge line and reading the pressure gauge. This pressure should be 20 psi (1.4 bar) higher than the maximum operating pressure.

CAUTION: Do not run the pump for more than 15 seconds with the discharge valve completely closed. If adjustments need to be made, refer to "Relief Valve Setting & Adjustment."

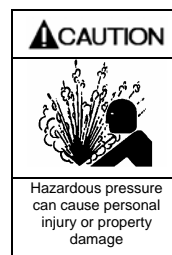

Incorrect settings of the pressure relief valve can cause pump component failure, personal injury, and property damage.

OPERATION

RUNNING THE PUMP IN REVERSE ROTATION

NOTICE:

Operate the pump in reverse rotation for no more than 10 minutes and only when a separate pressure relief valve is installed to protect the pump from excessive pressure.

It may be desirable to run the pump in reverse rotation for system maintenance. The pump will operate satisfactorily in reverse rotation for a LIMITED time, **at a reduced performance level.**

FLUSHING THE PUMP

NOTICE:

If flushing fluid is to be left in the pump for an extended time, it must be a lubricating, non-corrosive fluid. If a corrosive or non-lubricating fluid is used, it must be flushed from the pump immediately.

1. To flush the pump, run the pump with the discharge valve open and the intake valve closed. Bleed air into the pump through the intake gauge plug hole or through a larger auxiliary fitting in the intake piping. Pump air for 30 second intervals to clean out most of the pumpage. A drain plug is provided on the bottom of the cylinder to facilitate cleaning.
2. Run a system compatible flushing fluid through the pump for one minute to clear out the remainder of the original pumpage. Restrict a valve in the discharge line to build up 10 psi (0.7 bar) to force flushing liquid through the bearing seal chamber.
3. To flush out the pressure relief valve (if equipped), close the valve in the discharge line for 15 seconds while pumping the flushing liquid.
4. If necessary, repeat steps 2 and 3.
5. To remove the flushing fluid, follow step 1 above.

NOTICE:

After flushing the pump some residual fluid will remain in the pump and piping.

NOTICE:

Properly dispose of all waste fluids in accordance with the appropriate codes and regulations.

OPERATION

PUMP RELIEF VALVE

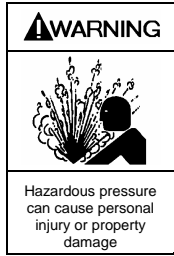

An external bypass valve and/or an internal relief valve **MUST** be installed in the system to protect the pump from excessive pressure.

Hazardous pressure can cause personal injury or property damage

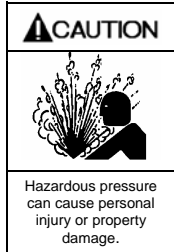

Incorrect bypass valve or internal relief valve settings can cause pump component failure, personal injury, and property damage.

Hazardous pressure can cause personal injury or property damage.

WARNING

Internal bypassing of liquid elevates liquid temperature. Only use the internal relief valve for brief periods and at differential pressures below 125 psi (8.6 bar). For extended periods or higher pressures, internal bypass port must be plugged and the liquid returned back to the source.

1.25 – 2.5' size SNP pumps are offered with an optional relief valve assembly which is bolted onto the pump casing. The valve may be used as an internal relief valve, or as an external bypass, piped back to the storage tank (see Figure 4). Its purpose is to protect the pump or pumping system from excessive pressure. The valve is not meant to be used for prolonged recirculation. If the optional Blackmer relief valve is not fitted, an external bypass valve **MUST** be fitted.

The 3" SNP is fitted with an internal pressure relief valve that bypasses internally back to the suction side of the pump.

When pumping highly volatile liquids under a high suction lift, and cavitation or starving of the pump exists, partial closing of the discharge valve will result in excessive noise in the relief valve. Plumbing the relief valve so flow is directed back to the storage tank or adding an external back-to-tank bypass valve is recommended when operating under these conditions.

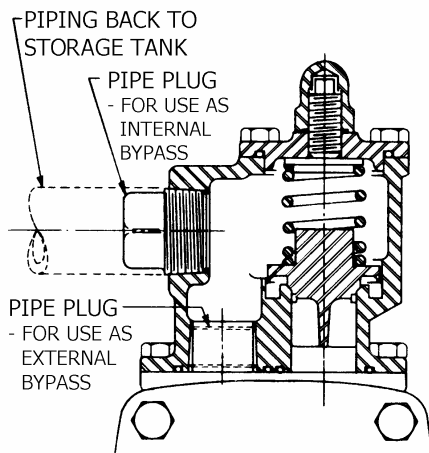
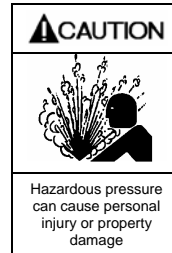

Figure 4 – Relief Valve

RELIEF VALVE SETTING AND ADJUSTMENT

The relief valve pressure setting is marked on a metal tag attached to the valve cover. Set the relief valve at least 15 - 20 psi (1.0 - 1.4 Bar) higher than the operating pressure, or the external bypass valve setting (if equipped).



Incorrect settings of the pressure relief valve can cause pump component failure, personal injury, and property damage.

Hazardous pressure can cause personal injury or property damage

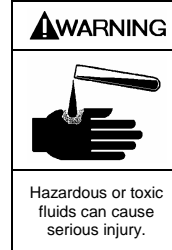

Relief valve cap is exposed to pumpage and will contain some fluid

Hazardous or toxic fluids can cause serious injury.

DO NOT remove the R /V Cap OR adjust the relief valve pressure setting while the pump is in operation.

1. To **INCREASE** the pressure setting, remove the relief valve cap (1), loosen the locknut (3), and turn the adjusting screw *inward*, or clockwise. Replace the valve cap.
2. To **DECREASE** the pressure setting, remove the relief valve cap (1), loosen the locknut (3), and turn the adjusting screw *outward*, or counterclockwise. Replace the valve cap.

Refer to the individual Blackmer pump parts lists for various spring pressure ranges. Unless specified otherwise, pumps are supplied from the factory with the relief valve adjusted to the mid-point of the spring range.

MAINTENANCE

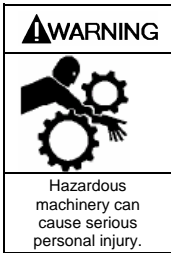

Failure to disconnect and lockout electrical power or engine drive before attempting maintenance can cause severe personal injury or death

Hazardous machinery can cause serious personal injury.

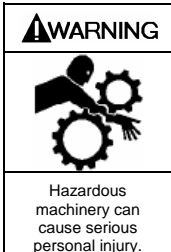

Failure to stop the pump before adjusting the shaft packing can cause severe personal injury.

Hazardous machinery can cause serious personal injury.

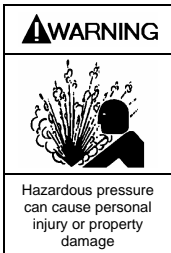

Failure to relieve system pressure prior to performing pump service or maintenance can cause personal injury or property damage.

Hazardous pressure can cause personal injury or property damage

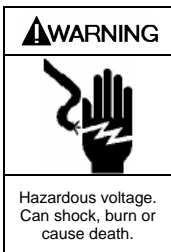

Failure to disconnect and lockout electrical power before attempting maintenance can cause shock, burns or death

Hazardous voltage. Can shock, burn or cause death.



Disconnecting fluid or pressure containment components during pump operation can cause serious personal injury, death or major property damage

Hazardous pressure can cause personal injury or property damage

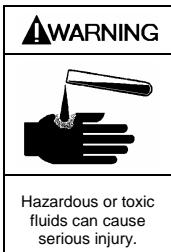

If pumping hazardous or toxic fluids, system must be flushed and decontaminated, inside and out, prior to performing service or maintenance

Hazardous or toxic fluids can cause serious injury.

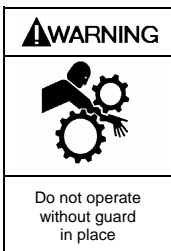

Operation without guards in place can cause serious personal injury, major property damage, or death.

Do not operate without guard in place

NOTICE:

Maintenance shall be performed by qualified technicians only. Following the appropriate procedures and warnings as presented in this manual.

SCHEDULED MAINTENANCE

STRAINERS

Strainers must be cleaned regularly to avoid pump starvation. Schedule will depend upon the application and conditions.

LUBRICATION

NOTICE:

To avoid possible entanglement in moving parts do not lubricate the gear reducer or any other parts while the pump is running.

Sleeve bearings (bushings) are lubricated by the liquid being pumped. Additional lubrication is not required.

IF EQUIPPED: Blackmer gear reducers are shipped from the factory without oil in the gearcase. Fill with the grade of oil indicated on the reducer tag. Change the oil after the first 48 hours of use and approximately every 500 hours of use thereafter.

VANE REPLACEMENT

NOTICE:

Maintenance shall be performed by qualified technicians only. Follow the appropriate procedures and warnings as presented in manual.

1. Remove the head assembly and all other parts on the outboard (non-driven) side of the pump. See the "Pump Disassembly" Section.
2. Turn the shaft by hand until a vane (14) comes to the top (12 o'clock) position of the rotor.

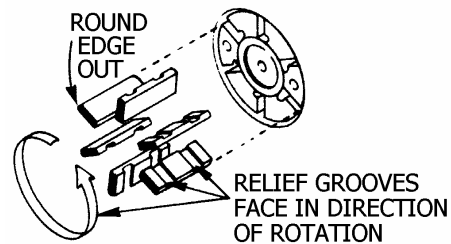

Figure 5 – Vane Replacement

3. Remove and replace the vane, making sure to install the vane with the rounded edge outward to contact the cylinder.
4. Rotate the shaft until the next rotor slot is in the top position, and replace the vane.
5. Continue this procedure until all new vanes are in place.
6. Reassemble the pump as instructed in "Pump Assembly."

MAINTENANCE

PUMP DISASSEMBLY

NOTICE:

FOLLOW ALL HAZARD WARNINGS AND INSTRUCTIONS PROVIDED IN THE "MAINTENANCE" SECTION OF THIS MANUAL.

NOTE: The numbers in parentheses following individual parts indicate reference numbers on the Pump Parts List.

1. On the outboard (non-driven) side of the pump, remove the head capscrews (21A), head (23) and disc (71). Avoid damaging the head seal ring (72) and disc (71).
NOTE: The sleeve bearing (24) is press fit into the head and should not be removed unless replacement is necessary (see "Sleeve Bearings").
2. Turn the shaft by hand until a vane (14) comes to the top (12 o'clock) position of the rotor. Remove each vane in turn.
3. On the opposite (inboard) end of the pump, clean the pump shaft thoroughly, making sure the shaft is free of nicks, burrs, or paint that might damage the packing or mechanical seal when the inboard head is removed.
4. **PUMPS EQUIPPED WITH PACKING**
 - a. Remove the packing locknuts (18), studs (17) and packing follower (75).
 - b. Remove the head capscrews (21), bracket (108), head (20) and disc (71). Avoid damaging the head seal ring (72) and disc (71). **NOTE:** The sleeve bearing (24) is press fit into the head and should not be removed unless replacement is necessary (see "Sleeve Bearings").
 - c. The packing rings (19) and packing washer (58) can be pulled from the inboard hub with the use of a corkscrew tool or screwdriver.

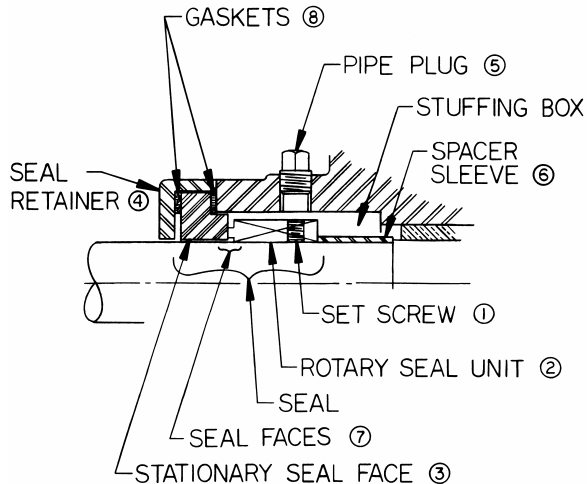

Figure 6 – Commercial Mechanical Seal

5. **PUMPS EQUIPPED WITH BLACKMER TRIPLE-LIP SEAL OR A COMMERCIAL MECHANICAL SEAL**
 - a. Loosen all setscrews before removing the head assembly. For further instructions on the disassembly and assembly of commercial mechanical seals, refer to the separate literature accompanying the seal.
 - b. Remove the head capscrews (21), bracket (108), head (20) and disc (71). Avoid damaging the head seal ring (72) and disc (71). **NOTE:** The sleeve bearing (24) is press fit into the head and should not be removed unless replacement is necessary (see "Sleeve Bearings").
6. From the driven side of the pump, grasp the rotor in the 3 and 9 o'clock positions, and gently pull the rotor and shaft (13) out of the cylinder. **CAUTION:** Use care to avoid injury-the rotor and shaft is heavy and may have sharp edges.

PARTS REPLACEMENT

1. If any of the O-rings have been removed or disturbed during disassembly, they must be replaced with new O-rings. **NOTE:** PTFE O-rings should be heated in hot water to aid installation.
2. Excessive or continuous leakage around the pump shaft may be an indication of a damaged mechanical seal, worn packing, or a damaged or worn sleeve bearing.
 - a. If a mechanical seal has been leaking, it is recommended the entire seal be replaced. Refer to "General Pump Troubleshooting" for possible causes of seal leakage.
 - b. If the packing is leaking excessively, refer to "Packing Adjustment." If this does not solve the problem, a complete new set of packing rings should be installed.
 - c. If the pump shaft indicates an excessive amount of radial "play," the sleeve bearing in the hub should be replaced.
3. Worn or scored discs may be reused if interchanged from one head to the other with the new side toward the rotor.

MAINTENANCE

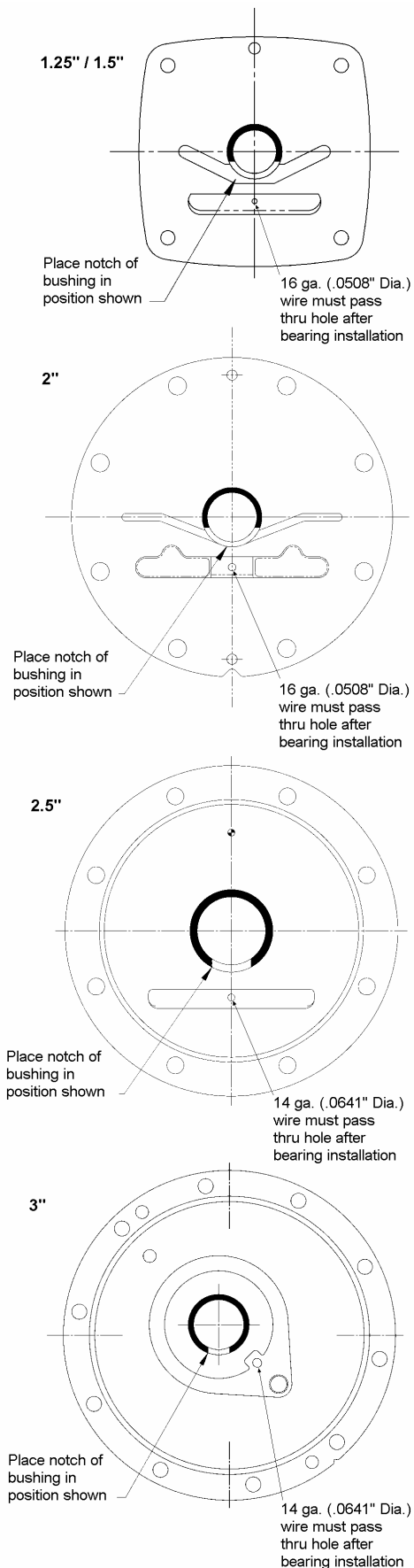

Figure 7a – Sleeve Bearing Alignment

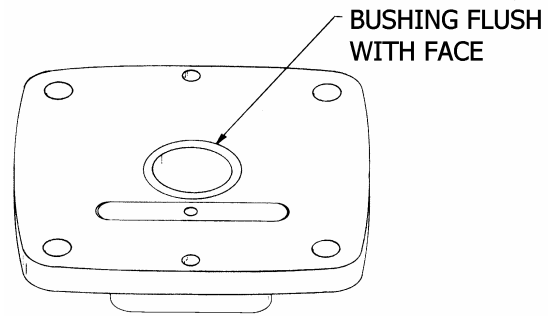

Figure 7b – Sleeve Bearing Installation

4. SLEEVE BEARINGS

If the sleeve bearing has been removed from the head, a new bearing must be installed.

- To aid installation, heat the head in an oven at 200°F (93°C) before installing the bearing.
- Coat the new bearing with a quality grade of bearing grease, and place it on the inside face of the head with the notched end UP. **Align the notch in the bearing with the groove in the head.** See figure 7a.
- Using an arbor press, press the bearing into the head in one continuous motion, until it is flush with (or slightly below) the inside face of the head. Starting and stopping the pressing motion may result in a cracked bearing.
- Ensure that the hole in the face of the head is open after inserting the bushing. See figure 7a.

5. CYLINDER BORE

Examine the cylinder bore carefully for tiny 'pin head' projections caused by foreign material in some fluids. Carefully scrape off the small projections and smooth the bore with emery as needed.

MAINTENANCE

PUMP ASSEMBLY

Before reassembling the pump, inspect all component parts for wear or damage, and replace as required. Wash out the bearing/seal recess of the head and remove any burrs or nicks from the rotor and shaft.

1. Place a small amount of Moly-grease on all capscrews before assembly to prevent galling.
2. Start with the OUTBOARD side of the pump.

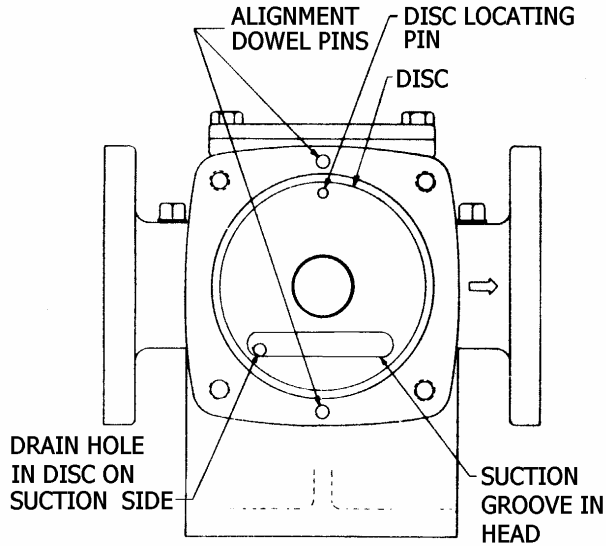

Figure 8 – Hole in Disc

3. Place the outboard disc (71) and seal ring (72) on the cylinder (12) so that the hole in the disc will be toward the INTAKE side of the pump. See Fig. 8.
4. Place the outboard head (23) on the cylinder (12) with the suction groove toward the bottom, using the dowel pin (25A) for alignment. See Figure 8.
 - a. Model SNPJ2.5: Place the O-rings (72A and 72B) and the steam jacket (59) on the head.
 - b. All Models: Tighten the head capscrews evenly to ensure that the head is properly seated and the seal ring fully compressed.
 - c. Secure the bearing cover (27) and seal ring (26) to the head with the four capscrews (28).

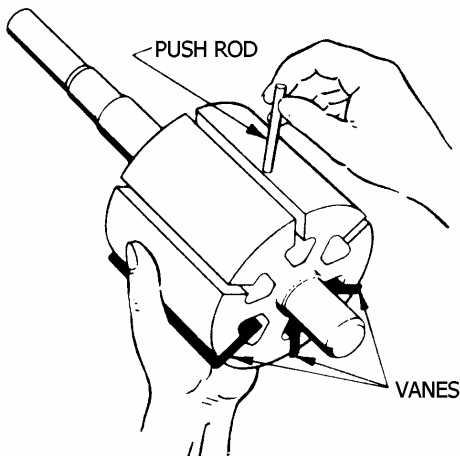

Figure 9 – Pushrod Installation

5. Rotor and Shaft

- a. Install the pushrods and the 2 (or 3) bottom vanes into the rotor. The rounded edge of the vanes must be outward to contact the bore of the cylinder and the relief grooves facing in the direction of rotation. See Figs. 5 and 9
- b. Holding the vanes in place, install the rotor/shaft into the cylinder using care not to damage the disc or shaft.
- c. Turn the shaft by hand until an empty slot comes to the 12 o'clock position, insert a vane, and move on to the next slot.
6. Place the inboard disc (71) and seal ring (72) on the cylinder (12) so that the hole in the disc will be toward the INTAKE side of the pump. See Fig. 8.
7. Place the inboard head over the shaft and against the cylinder (12) with the suction groove toward the bottom, using the dowel pin (25A) for alignment. See Figure 8.
 - a. Jacketed Models: Place the O-rings (72A and 72B) on the head.
 - b. All models except the SNP3A: Place the Bracket / Jacket (108 or 59) onto the head.
 - c. All models: Tighten the head capscrews evenly to ensure that the head is properly seated and the seal ring fully compressed.

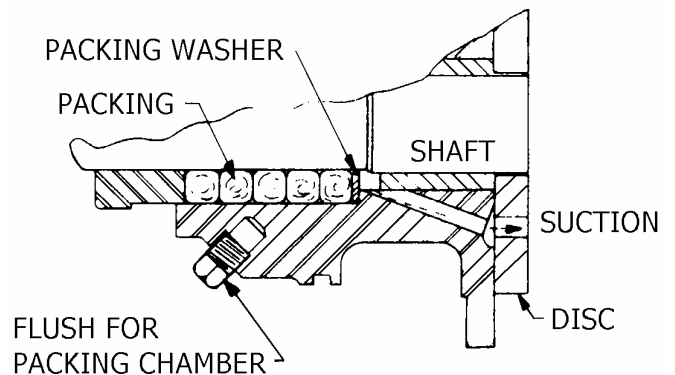

Figure 10 - Packing

8. PACKING AND PACKING FOLLOWER

When necessary to repack, use a full set of new packing rings. Packing is furnished in sets with the correct number of rings. Never add new rings to an old set of packing.

- a. Insert the packing washer (58) into the stuffing box of the inboard hub.
- b. Insert each packing ring (19) separately into the stuffing box, using the packing follower (75) to properly seat each ring after placement. Be sure to stagger the split joints approximately 180 degrees apart so that they are not overlapping or near the joint of the preceding ring.
- c. Install and tighten the two packing follower studs (17).
- d. Place the packing follower (75) snugly against the packing. Install the two packing follower stud nuts (18) and **tighten lightly**. **NOTE:** Adjustment to the packing follower should be made while pumping liquid (see "Packing Adjustment").

MAINTENANCE

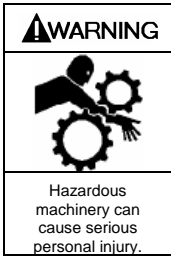

Failure to stop the pump before adjusting the shaft packing can cause severe personal injury.

9. PACKING ADJUSTMENT

Packing must be properly adjusted to prevent overheating.

- While the liquid is being pumped, check for leakage from the stuffing box. STOP the pump and uniformly tighten the packing follower stud nuts (18) 1/4 turn at a time to reduce leakage.
- Restart the pump and check the stuffing box temperature several minutes after each adjustment for signs of overheating.
- Check the packing again after 20-30 minutes of running the pump, and readjust if necessary.

NOTE: Some leakage is desirable to lubricate the packing, but in some cases is unacceptable, depending on the application.

10. BLACKMER TRIPLE-LIP SEAL (if equipped)

On pumps equipped with a Blackmer triple-lip seal, refer to the separate literature accompanying the triple-lip seal for installation instructions.

11. COMMERCIAL MECHANICAL SEAL (if equipped)

On pumps equipped with a commercial mechanical seal, refer to the separate literature accompanying the mechanical seal for installation instructions.

12. SHAFT SUPPORT BEARING (SNP3A if equipped)

- Screw the short threaded ends of the two hex studs (106E) firmly into the holes in the head.
- Place the bearing flange (106) on the studs and tighten the locknuts (106A).
- Slide the bearing and lock collar (106B) on the shaft until it is firmly seated in the bearing flange (106A).
- Push inward on the bearing and lock collar (106B) while turning the lock collar by hand in the same direction as the shaft rotation.
- Lock the collar to the shaft with a punch in the same direction as the shaft rotation. See Fig. 11.
- Bolt on the flange cover (106C).
- If the shaft does not turn freely, loosen the lock collar and make sure the bearing is firmly seated in the bearing flange (106). Re-tighten the lock collar.

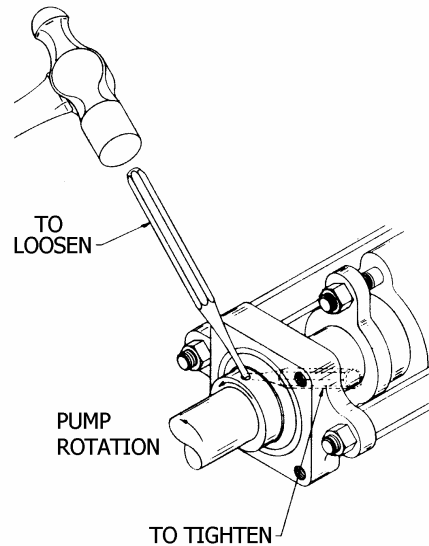

Figure 11 – Shaft Support Bearing Lock Collar

13. RELIEF VALVE ASSEMBLY (if equipped)

- Insert the valve (9) into the relief valve body (6) with the fluted end inward.
- Install the relief valve spring (8) and spring guide (7) against the valve.
- Attach a new relief valve gasket (10) and the valve cover (4) on the relief valve body (6).
- Screw the relief valve adjusting screw (2) into the valve cover until it makes contact with the spring guide (7).
- Install the relief valve cap (1) and gasket (88) after the relief valve has been precisely adjusted.

NOTICE:

The relief valve setting MUST be tested and adjusted more precisely before putting the pump into service. Refer to "Relief Valve Setting and Adjustment"

- Reinstall coupling, shaft key, and coupling guards.

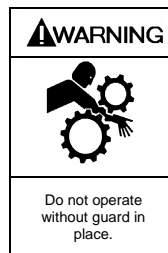

Operation without guards in place can cause serious personal injury, major property damage, or death.

- Refer to "Pre-Start Up Check List" and "Start Up Procedures" sections of this manual prior to pump operation.

TROUBLESHOOTING

NOTICE:

MAINTENANCE SHALL BE PERFORMED BY QUALIFIED TECHNICIANS ONLY, FOLLOWING THE APPROPRIATE PROCEDURES AND WARNINGS AS PRESENTED IN THIS MANUAL.

LEAKAGE

Location

Between the head & casing

Probable Cause/Corrective Action

Damaged head O-ring: Inspect and replace if necessary.

Burrs/dirt in head O-ring groove or cylinder: File and clean as necessary.

Around the shaft

Packing: Adjust the packing. If this does not solve the problem, replace the packing with a complete new set.

NOTE: On pumps equipped with packing, some leakage is necessary, and in some cases is desirable, depending on the application.

Damaged shaft surface: Check the surface of the shaft in the seal area for damage. File any small burrs or ridges. If damage is severe, replace rotor & shaft.

New Mechanical Seals: New seals may leak slightly at start up, but should seal up shortly thereafter.

Damaged mechanical seals: Check for damaged O-rings or cracked, scratched or worn seal faces

SHAFT BINDING

Probable Cause

Burrs, dirt or foreign particles on the heads or discs.

Corrective Action

During assembly, both heads and discs must be clean and smooth. File any burrs or rough spots, and wipe the discs with a clean cloth and alcohol to remove any dirt or foreign particles.

Excessively tight packing.

Refer to "Packing Adjustment".

Contaminated mechanical seal faces.

Any trace of grease or dirt on the seal faces will prevent the faces from mating properly, causing the rotor and shaft to bind or turn hard. Use a tissue paper & alcohol to clean the seal faces. NOTE: Apply a light oil or suitable lubricant to bronze seal faces only.

Other possible causes of shaft binding

- Foreign particles on rotor, liner or vanes.
- Damaged vanes or rotor.

- Bent push rods.
 - Liquids that "set up" when inactive.
-

OVERHEATING

Location

Pump equipped with internal relief valve.

Probable Cause/Corrective Action

Continual, full bypassing of the liquid: Properly adjust the relief valve so that the pump will not bypass during normal operation.

WARNING: Internal bypassing of liquid elevates the liquid temperature. Only use the internal bypass valve for brief periods and at differential pressures below 125 psi.

For extended periods of higher pressures, the internal bypass port must be plugged and the liquid returned back to the source.

Pumps with packing.

Packing: NEVER tighten the packing without checking afterward for overheating. If packing is old or worn, it will overheat and should be replaced.

Other possible causes of overheating

- Improper relief valve adjustment (See "Relief Valve").

- Plugged discharge line.
 - Closed valve.
-

LOW DELIVERY RATE

Probable Cause

Relief valve setting too low, causing the liquid to bypass.

Corrective Action

Set the relief valve 20 psi (1.4 bar) higher than the differential pressure.

Other possible causes of a low delivery rate

- Restriction in the suction line.
- Resistance in the discharge line.
- Air leaks in the suction line.
- Damaged or worn pump parts.

- Pump speed too low or too high.
 - Relief valve leaking.
 - Relief valve sticking open, or not properly seating.
 - Dirty strainer.
-

TROUBLESHOOTING continued

EXCESSIVE NOISE AND VIBRATION

Probable Cause

Cavitation or vaporization of the liquid resulting from excessive vacuum on the pump due to starved suction.

Entrained air or vapors in the pump.

Pump speeds exceed the recommended maximum.

Continual or long term bypassing of liquid through relief valve.

Other possible causes of noise and vibration

- Excessively worn vanes or discs.
- Bearing Worn or Damaged.
- Loose or improperly installed piping.

Corrective Action

Check for:

- Inlet piping too long or too small in diameter.
- Strainer plugged or dirty.
- Undersized or restrictive fittings, such as globe valves or partially closed valves.
- Excessive amount of elbows.
- Suction lift too great.
- Pump speed too high for the viscosity of the liquid being pumped.

Check pipe joints for leakage of air. Sometimes when recirculating liquid in a tank, the returning liquid falling through the air carries air down into the tank, which eventually gets back into the pump.

Check the recommended RPM for your specific application.

Check for restriction in the discharge line, or an improper relief valve adjustment (See "Relief Valve" on Page 6).

- Misalignment of pump and driver.
- Pump base not properly mounted.
- Insufficient Oil in the Gear Reducer

POOR OR NO PRIMING

Probable Cause

- Air leaks in the suction line.
- Restriction in the suction line.
- Damaged or worn pump parts.
- Too much lift for the vapor pressure of the fluid.
- A dirty or clogged strainer.
- Worn vanes.
- Suction Valve Closed.
- Incorrect pump rotation
- Relief Valve partially open, valve not seating properly.

DAMAGED VANES

Probable Cause

- Foreign objects entering the pump.
- Running the pump dry for extended periods of time.
- Cavitation.
- Viscosity too high for the vanes and /or the pump speed.
- Incompatibility with the liquids pumped.
- Excessive heat.
- Worn or bent push rods, or worn push rod holes.
- Settled or solidified material in the pump at start-up.
- Hydraulic hammer - pressure spikes.
- Vanes installed incorrectly (see "Vane Replacement").

BROKEN SHAFT

Probable Cause

- Foreign objects entering the pump.
- Viscosity too high for the pump speed.
- Relief valve not opening.
- Hydraulic hammer - pressure spikes.
- Pump/driver, driveline/drive shaft misalignment.
- Excessively worn vanes or vane slots.
- Settled or solidified material in the pump at start-up.
- Overtightened V-belts, if used.

SEAL LEAKAGE

Probable Cause

- O-rings not compatible with the liquids pumped.
- O-rings nicked, cut or twisted.
- Shaft at seal area damaged, worn or dirty.
- Pump sleeve bearings worn excessively.
- Excessive cavitation.
- Mechanical seal faces cracked, scratched, pitted or dirty.

MOTOR OVERLOAD

Probable Cause

- Horsepower of motor not sufficient for application
- Improper wire size / wiring and/or voltage to motor.
- Misalignment in pump drive system.
- Excessive viscosity, pressure or speed.
- Faulty or worn bearings.
- Rotor rubbing against head or cylinder.
- Dirty mechanical seal faces.

NOTES

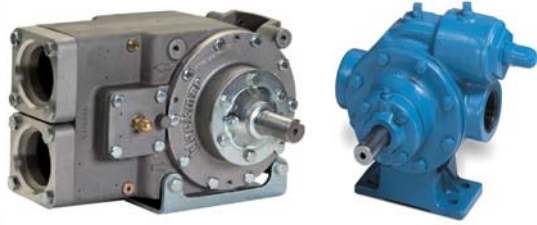

Sliding Vane Pumps: 5 to 2200 GPM
Refined Fuels, Liquefied Gases, Process,
Transport, Marine

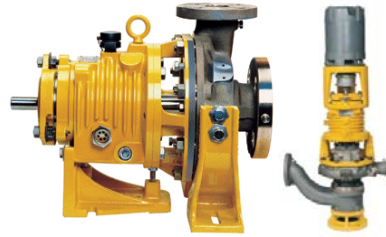

System One Centrifugal Pumps
10 to 7500 GPM
Process, Marine



C-Series Eccentric Disc Pumps
1 to 150 GPM
Shear Sensitive, Food, Process



Abaque Peristaltic Hose Pumps
0.5 to 220 GPM
High Lift, Solids, Abrasives



Rotary Vane and Screw Compressors
Dry Bulk Unloading



Reciprocating Gas Compressors
Liquefied Gas Transfer, Boosting, Vapor Recovery



Hydraulic Coolers
Complete Packages

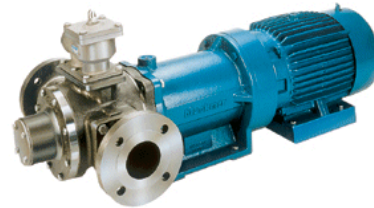

Magnetic Drive Pumps
Iron and Stainless, 14 to 333 GPM



Hand Operated Pumps
Dispensing, Transfer, In-line



Accessories
Gear Reducers, Bypass Valves, Strainers

Visit www.blackmer.com for complete information on all Blackmer products



1809 Century Avenue, Grand Rapids, Michigan 49503-1530 U.S.A.
Telephone: (616) 241-1611 • Fax: (616) 241-3752
E-mail: blackmer@blackmer.com • Internet Address: www.blackmer.com