

BLACKMER PARTS LIST

PUMP MODEL: GX3E

961820 **PARTS LIST**
Page 1 of 4 **101-B03**

See Instructions 101-B00 for Installation, Operation and Maintenance

Section 101
Effective Sept 2007
Replaces April 2004

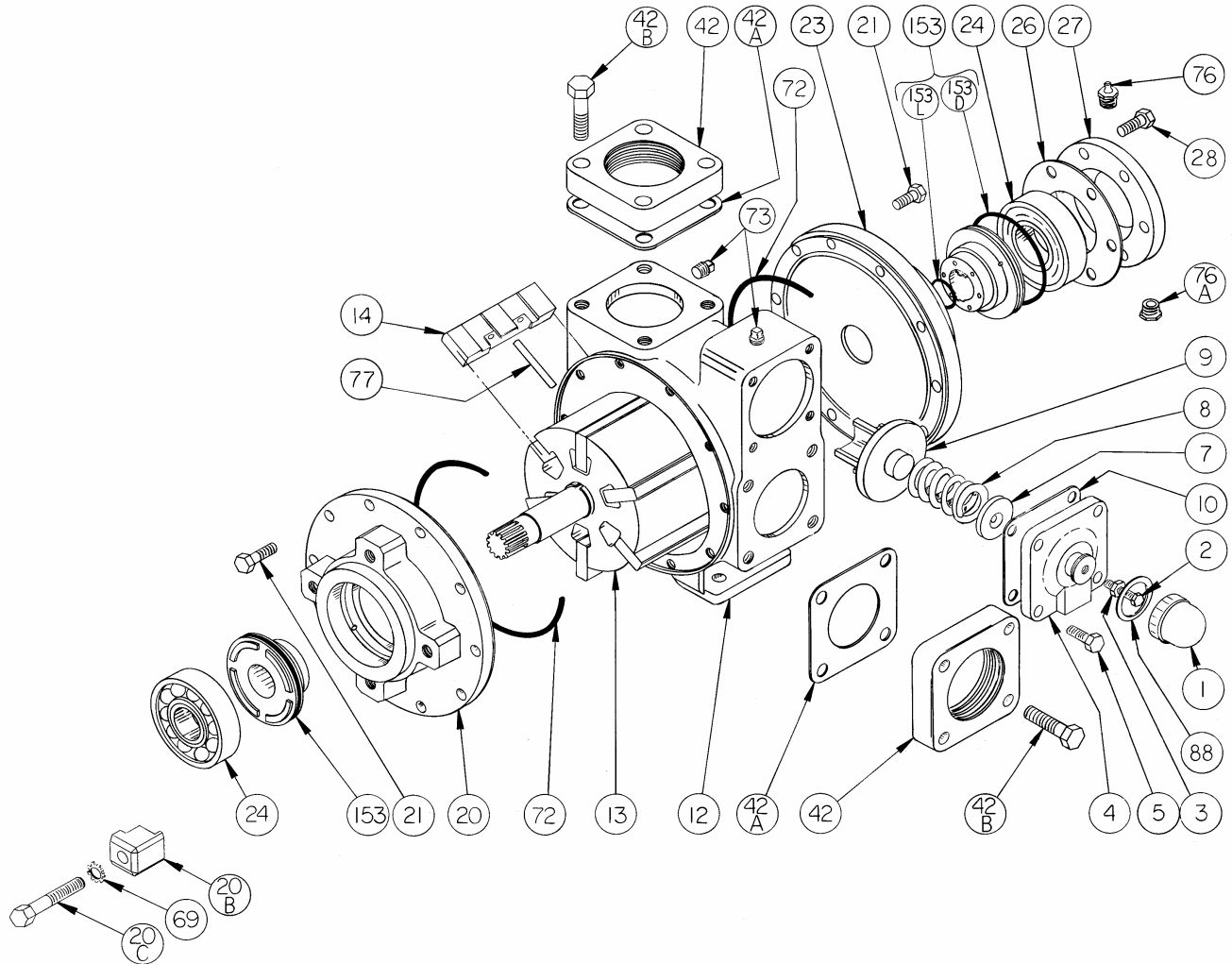

Ref. No.	Description	Parts per Pump	Part No.	Ref. No.	Description	Parts per Pump	Part No.
1	Cap - Relief Valve (R/V)	1	413952	20C	Capscrews - Clamp	4	920547
2	Adjusting Screw - R/V	1	431808	21	Capscrews - Head	20	920369
3	Locknut - Adjusting Screw	1	922923	23	Head - Outboard	1	031815
4	Cover - R/V	1	411807	24	Ball Bearing	2	¹ 903172
5	Capscrew - R/V Cover	4	920331	26	Gasket - Bearing Cover	1	¹ 385125
7	Spring Guide - R/V	1	421805	27	Bearing Cover	1	041817
8	Spring - R/V (36-50 psi)	1	471805	28	Capscrews - Bearing Cover	6	920285
	Spring - R/V (51-110 psi)		471806	42	Flange - 3" NPT * (Std.)	2	651803
9	Valve - R/V (Std.)	1	451807	42A	Gasket - NPT Flange (Std.)	2	¹ 381816
	Valve - R/V (Nickel Plated)		451808	42B	Capscrews - NPT Flange (Std.)	8	920532
10	Gasket - R/V Cover	1	¹ 531803	69	Lockwasher - Clamp	4	909630
12	Cylinder	1	021805	72	O-Ring - Head (FKM) (Std.)	2	¹ 711938
13	Rotor & Shaft	1	261851		O-Ring - Head (PTFE)		702082
14	Vane - Duravane (Std.)	6	¹ 091819	73	Gage Plug	2	908198
	Vane - EC Cast Iron		091821	76	Grease Fitting	1	317815
	Vane - EC Laminate		091829	76A	Grease Relief Fitting	1	701992
20	Head - Inboard	1	031825	77	Push Rod	3	¹ 121807
20B	Clamp	4	834001	88	Gasket - R/V Cap	1	¹ 533908
					Kit - Maintenance		898910

¹ Included in Maintenance Kit

* See Page 2 for Weld / ANSI flange options.

SS = Stainless Steel.

EC = Extra-Clearance.

Keep this parts list with the Installation, Operation and Maintenance Instructions.

MECHANICAL SEALS

Ref. No.	Part Name	Parts Per Pump	Part No.
153	Mechanical Seal Complete - (Std.) Cast Iron Stationary Seat, Carbon Seal Face, FKM O-Rings. (IVCV)	2	¹ 331883
	Mechanical Seal Complete - Cast Iron Stationary Seat, PTFE O-Ring, Carbon Seal Face w/ PTFE Seal Ring. (IACT)		331873
153D	O-Ring - Stationary (FKM)	2	711931
	O-Ring - Stationary (PTFE)		702080
153L	O-Ring - Rotating (FKM)	2	701962
	Seal Ring - Rotating (PTFE)		**

¹ Included in Maintenance Kit

** PTFE Rotating Seal Ring is not available as a separate part.

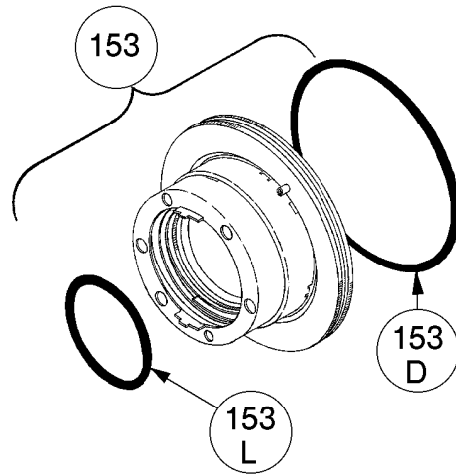

FLANGE OPTIONS

Ref. No.	Part Name	Parts Per Pump	Part No.
42	Flange - 3" Weld	2	655102
	Flange - 3" ANSI		651817
42B	Capscrews - Weld / ANSI Flange	8	920510
42C	O-Ring - Weld/ANSI Flg. (FKM)	2	701968
	O-Ring - Weld/ANSI Flg. (PTFE)		702101

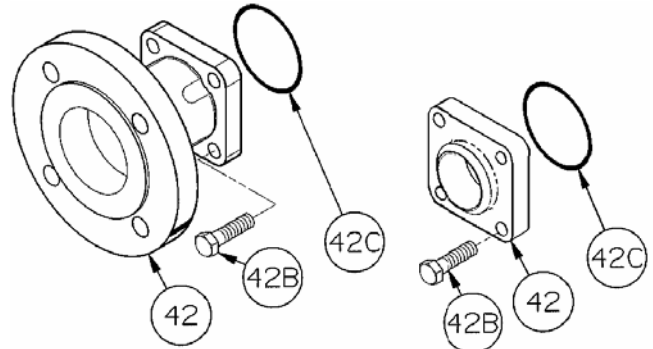

ANSI FLANGE

WELD FLANGE

HELICAL GEAR REDUCER MODEL: HRA

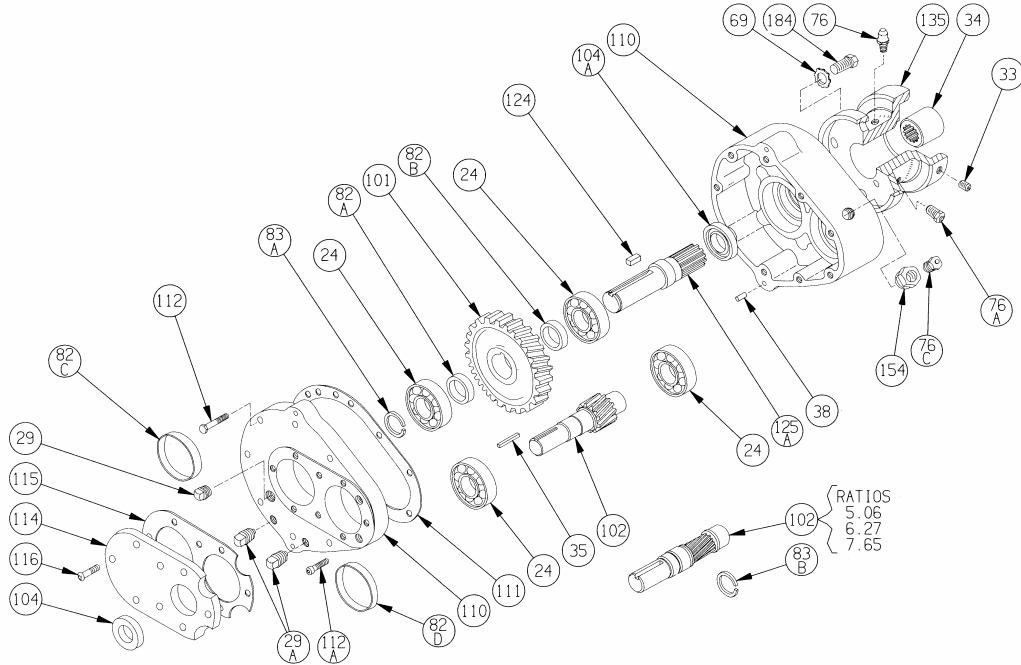

Ref. No.	Description	Parts per Pump	Part No.	Ref. No.	Description	Parts per Pump	Part No.
24	Bearing	4	903150	101	Gear	1	See Table
29	Oil Level Plug	1	908185	102	Pinion & Shaft	1	See Table
29A	Drain Plug	2	908100	104	Oil Seal	1	331910
33	Set Screw	2	922190	104A	Oil Seal	1	331923
34	Splined Coupling (Includes Snap Ring)	1	906077	110	Gearbox Assembly ¹	1	894001
35	Key – Pinion	1	909177	111	Gasket – Cover	1	814000
38	Dowel Pin	2	930739	112	Capscrews – Cover	7	920235
69	Lockwasher – Spool	4	909630	112A	Capscrews – Cover	2	920233
76	Grease Fitting	1	317815	114	Closure Plate	1	*
76A	Grease Relief Fitting	1	701992	115	Gasket – Closure Plate	1	814002
76C	Fill & Vent Plut	1	701988	116	Capscrews – Closure Plate	8	922754
82A	Spacer Ring	1	See Table	124	Key – Splined Shaft	1	909175
82B	Spacer Ring	1	See Table	125A	Splined Shaft	1	704010
82C	Spacer Ring	1	See Table	135	Spool	1	834010
82D	Spacer Ring	0 - 1	See Table	154	Bushing	1	908794
83A	Retaining Ring	1	See Table	184	Capscrew – Spool	4	920316
83B	Retaining Ring	0 - 1	See Table				

* Non-saleable item – included with Gearbox Assembly. ¹ Gearbox Assembly includes Ref. Nos. 38, 110, 111, 112, 112A, 114, 115, 116.

GEAR AND PINION SELECTION TABLE

Ratio	RPM	102 Pinion No.	Qty	101 Gear No.	Qty	SPACERS								RETAINING RINGS			
						82A	Qty	82B	Qty	82C	Qty	82D	Qty	83A	Qty	83B	Qty
2.24	780	915131	1	919931	1	374002	1	374002	1	374003	1	374003	1	903618	1	NONE	-
2.76	640	915125	1	919928	1	374002	1	374002	1	374003	1	374003	1	903618	1	NONE	-
3.40	520	915126	1	919929	1	374002	1	374002	1	374003	1	374003	1	903618	1	NONE	-
4.19	420	915127	1	919930	1	374002	1	374002	1	374003	1	374003	1	903618	1	NONE	-
5.06	350	915132	1	919932	1	374001	1	374004	1	374003	1	NONE	-	903618	1	903618	1
6.27	280	915133	1	919933	1	374001	1	374004	1	374003	1	NONE	-	903618	1	903618	1
7.65	230	915122	1	919922	1	374001	1	374004	1	374003	1	NONE	-	903618	1	903618	1

NOTE: Nominal speed is based on 1740 rpm input.

NOTES



1809 Century Avenue, Grand Rapids, Michigan 49503-1530, U.S.A.
Telephone: (616) 241-1611 / Fax: (616) 241-3752
E-Mail: blackmer@blackmer.com / Internet: www.blackmer.com

Parts List 101-B03
Page 4 of 4