

BLACKMER PARTS LIST

PUMP MODELS: SNP2, SNPJ2 *

See Instructions 104-A00 for Installation, Operation and Maintenance

960257 **PARTS LIST**
Page 1 of 2 **104-A02**

Section | 104
Effective | Sept 2007
Replaces | June 2006

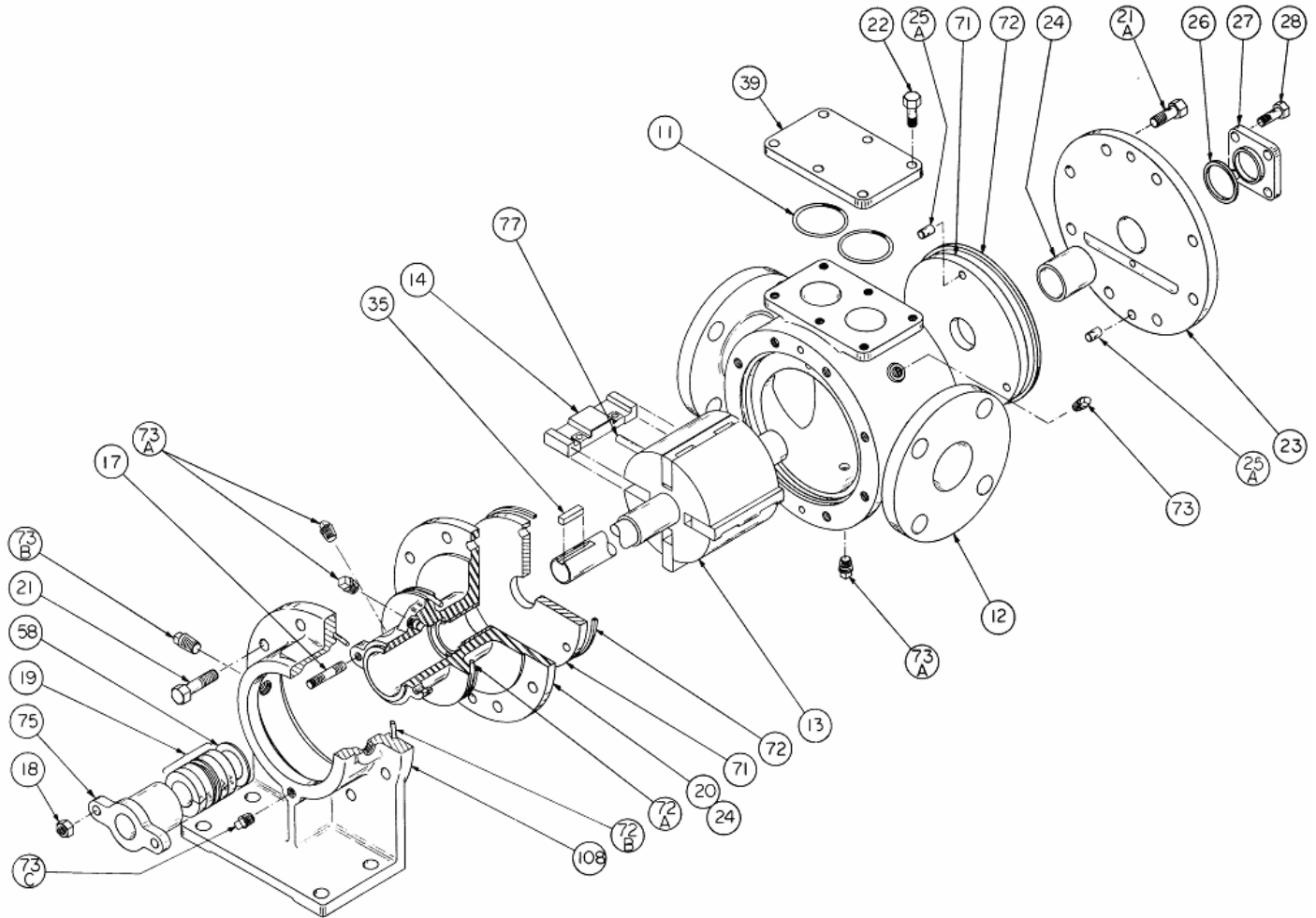

Ref. No.	Description	Parts per Pump	Part No.	Ref. No.	Description	Parts per Pump	Part No.
11	Seal Ring – Blanking Plate	2	¹ 533811	35	Key – Shaft	1	¹ 909178
12	Cylinder	1	023801	39	Plate – Blanking	1	493801
13	Rotor & Shaft	1	² 263801	71	Disc	2	² 063803
14	Vane – Duravane	4	¹ 091419	72	Seal Ring – Head	2	¹ 383801
	Vane – EC Laminate		¹ 091429	72A	O-Ring – Inboard Head (jacketed)	1	¹ 701991
20	Head & Bushing Asy. – Inboard	1	033803	72B	O-Ring – Steam Jacket (jacketed)	1	¹ 711934
21	Capscrews – Inboard Head	8	920366	73	Plug (1/4")	2	908193
21A	Capscrews – Outboard Head	8	920335	73A	Plug (1/8")	4	908183
22	Capscrews – Blanking Plate	6	920179	73B	Plug (3/8") (SNP w/ jackets)	2	908207
23	Head & Bushing Asy. - Outboard	1	033804	73C	Plug (1/8") (SNP w/ jackets)	1	908183
24	Sleeve Bearing	2	¹ 161402	77	Push Rod	2	¹ 833801
25A	Dowel Pin	6	930564	108	Mounting Bracket/Steam Jacket	1	833801
26	Seal Ring – Bearing Cover	1	¹ 711957	—	Kit - Maintenance	—	898946
27	Bearing Cover	1	043101	—	Kit - Maintenance (jacketed pumps)	—	898987
28	Capscrews – Bearing Cover	4	920129	—	Kit - Rebuild	—	899046
				—	Kit - Rebuild (jacketed pumps)	—	899087

¹ Included in Maintenance & Rebuild Kits. ² Included in Rebuild Kit.

* Effective Jan 2006, jackets are considered an option and no longer change the model number.

Keep this parts list with Installation, Operation and Maintenance Instructions.

SNP2 – RELIEF VALVE – OPTIONAL

Ref. No.	Part Name	Parts Per Pump	Part No.
1	Cap – Relief Valve (R/V)	1	413151
2	Adjusting Screw – R/V	1	433101
4	Cover – R/V	1	413801
5	Capscrews – R/V Cover	4	920129
6	Body – R/V	1	403801
7	Spring Guide – R/V	1	423101
8	Spring – R/V (25-50 psi)	1	471417
	Spring – R/V (51-75 psi)		471418
	Spring – R/V (76-100 psi)		471427
	Spring – R/V (101-150 psi)		471429
9	Valve – R/V	1	453803
10	Seal Ring – R/V Cover	1	533801
22	Capscrews – R/V Body	6	920179
29	Plug (1-1/4")	0-1	908244
29A	Plug (1") (External By-Pass)	0-1	908229
88	Gasket – R/V Cap	1	533101

SNP2 – SHAFT PACKING – STANDARD

Ref. No.	Part Name	Parts Per Pump	Part No.
17	Stud – Packing Follower	2	921369
18	Locknut – Packing Follower Stud	2	922821
19	Packing Set (5 Rings – Std.)	1	323102
58	Packing Washer	1	353101
75	Packing Follower	1	143801

SNP2 – MECHANICAL SEAL - OPTIONAL

Ref. No.	Part Name	Parts Per Pump	Part No.
16	Capscrew – Retainer	2	920227
82	Spacer – Seal	1	373802
126	Retainer – Seal	1	333110
153	Mechanical Seal Assy – Crane Type 9	1	333104

SNP2 – MECHANICAL SEAL - OPTIONAL

Ref. No.	Part Name	Parts Per Pump	Part No.
16	Capscrew – Retainer	2	920242
82	Spacer – Seal	1	373802
123	Gasket – Seal Retainer	1	383181
126	Retainer – Seal	1	333111
153	Mechanical Seal Assy – Durametallic	1	333103

SNP2 – TRIPLE-LIP CARTRIDGE SEAL - OPTIONAL

Ref. No.	Part Name	Seal	Seal Rebuild Kit
—	TRIPLE-LIP CARTRIDGE SEAL	333814	899101
220	Shaft Sleeve O-Ring	2	X
221	Shaft Sleeve	1	
222	Gasket	1	X
223	Gland Plate Assembly	1	
224	Element O-Ring	1	X
225	Seal Spacer	1	X
226	Seal Element	3	X
227	Flushing Spacer	1	X
228	Flushing Spacer O-Ring	1	X
229	Retaining Ring	1	
230	Snap Ring	1	X
231	Shaft Sleeve Setscrews	6	X
233	Gland Capscrew	4	
234	Flat Washer	4	

X = Parts included in Seal Rebuild Kit

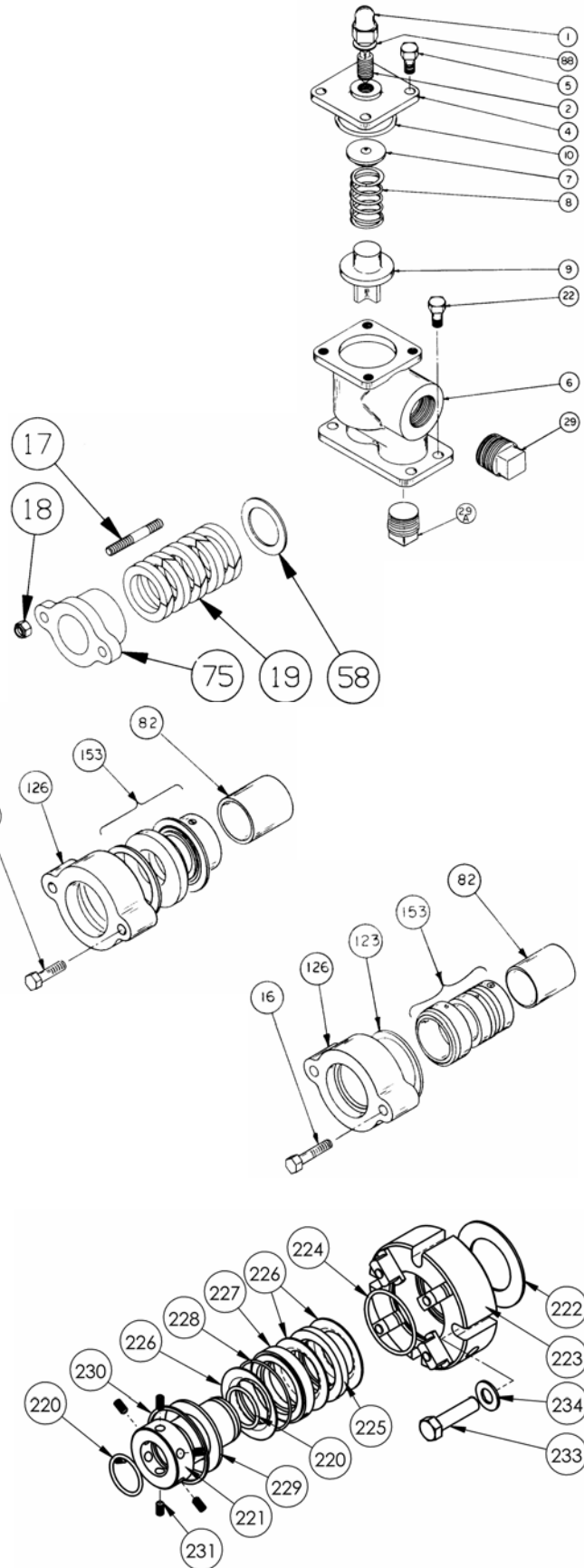

1809 Century Avenue, Grand Rapids, Michigan 49503-1530, U.S.A.
 Telephone: (616) 241-1611 / Fax: (616) 241-3752
 E-Mail: blackmer@blackmer.com / Internet: www.blackmer.com