

BLACKMER PARTS LIST

PUMP MODELS: TXD2A, TXSD2A (Double Ended Shafts) TX2A, TXS2A (Single Ended Shafts)

See Instructions 201-A00 for Installation, Operation and Maintenance

Section	201
Effective	Sept 2007
Replaces	Jan 2007

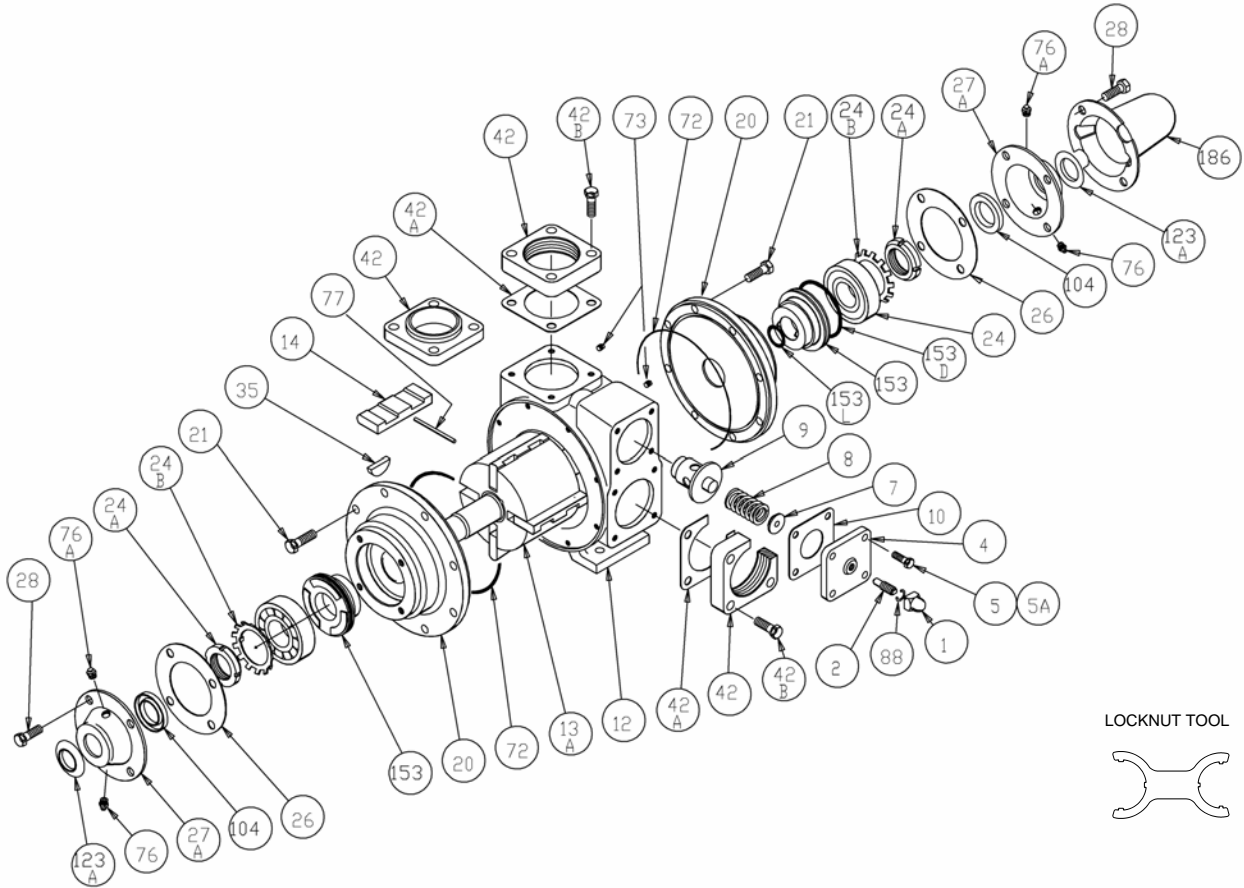

Ref. No.	Description	Parts Per Pump	Part No.	Ref. No.	Description	Parts Per Pump	Part No.
1	Cap – Relief Valve (R/V)	1	411453	26	Gasket – Bearing Cover	1 - 2	¹ 381406
2	Adjusting Screw – R/V	1	431401	27A	Bearing Cover	1 - 2	041431
4	Cover – R/V	1	411401		Bearing Cover – Outboard	0 - 1	041433
5	Capscrew – R/V Cover	3	920316	28	Capscrews – Bearing Cover	8	920285
5A	Capscrew w / Hole – R/V Cover	1	920310	35	Key – Shaft	1	¹ 909130
7	Spring Guide – R/V	1	423955	42	Flange – 2" NPT	1 - 2	651411
8	Spring – R/V (36-50 psi)	1	471415		Flange – 2" Weld		654405
	Spring – R/V (51-75 psi)		471420	42A	Gasket – Flange	2	¹ 381421
	Spring – R/V (76-110 psi) (Std.)		471425	42B	Capscrew – Flange	8	920351
	Spring – R/V (111-125 psi)		471428	72	O-Ring – Head (Buna-N) (Std. TXD)	2	¹ 701947
9	Valve – R/V (Std. TXD)	1	451417		O-Ring – Head (FKM) (Std. TXSD)		701914
	Valve – R/V (Ni Plated) (Std. TXSD)		451415		O-Ring – Head (PTFE)		702242
10	Gasket – R/V Cover	1	¹ 531403	73	Gage Plug	2	908198
12	Cylinder	1	021403	76	Grease Fitting	2	317815
13A	Rotor & Shaft – Double Ended	1	² 261411	76A	Grease Relief Fitting	2	701992
	Rotor & Shaft – Single Ended		³ 261410	77	Push Rod	2	¹ 123905
14	Vane – Duravane	4	¹ 091419	88	Gasket – R/V Cap	1	¹ 701981
20	Head (Std.)	2	¹ 031425	104	Grease Seal	1 - 2	¹ 331918
	Head with Drain		031426	123A	Dirt Shield	1 - 2	¹ 701480
21	Capscrews – Head	16	920331	186	Shaft Protector	0 - 1	341601
24	Ball Bearing	2	¹ 903156		Air Valve Kit		891454
24A	Locknut - Bearing	0 - 2	⁴ 903521		Tool - Locknut		903091
24B	Lock washer - Bearing	0 - 2	⁴ 903522		Kit – Maintenance (TXD2A only)		898950

¹ Included in Maintenance Kit

² Includes 24A & 24B

³ SE shaft does not use locknut (24A) or lockwasher (24B)

⁴ Earlier TXD2A and TXSD2A and current TX2A / TXS2A are not fitted with locknuts and lock washers.

The current DE rotor / shaft with locknuts and lock washers may be fitted in place of shafts without locknuts and lock washers.

Keep this parts list with Installation, Operation and Maintenance Instructions.

MECHANICAL SEALS

REF. NO.	PART NAME	PARTS PER PUMP	PART NO.
153	Mechanical Seal Complete - Std. TXD Cast Iron Stationary Seat, Carbon Seal Face, Buna-N O-Rings. (INCN)	2	¹ 331601
	Mechanical Seal Complete - Std. TXSD Cast Iron Stationary Seat, FKM O-Rings, Carbon Seal Face. (IVCV)		331655
	Mechanical Seal Complete - Cast Iron Stationary Seat, PTFE O-Ring, Carbon Seal Face w/ PTFE Seal Ring. (IACT)		331673
153D	O-Ring – Stationary (Buna-N)	2	701934
	O-Ring – Stationary (FKM)		701921
	O-Ring – Stationary (PTFE)		702056
153L	O-Ring – Rotating (Buna-N)	2	701922
	O-Ring – Rotating (FKM)		701980
	Seal Ring – Rotating (PTFE)		**

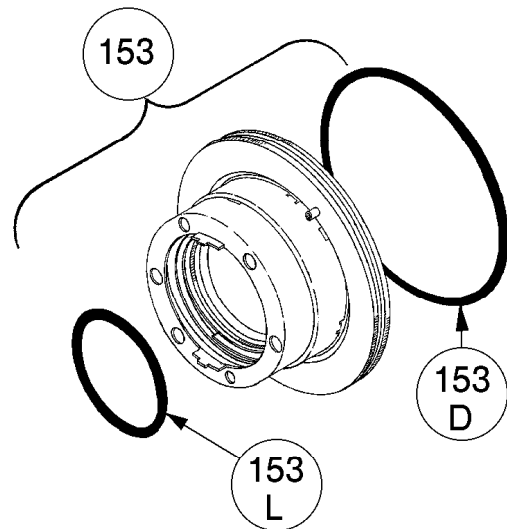

¹ Included in Maintenance Kit

** PTFE Rotating Seal Ring is not available as a separate part.

OPTIONAL HYDRAULIC MOTOR ADAPTER PARTS

REF. NO.	PART NAME	PARTS PER PUMP	PART NO. 1-1/4" Hyd Motor Shaft	PART NO. 1" Hyd Motor Shaft
See Below	Hydraulic Motor Adapter Kit *	See Below	891458	891205
26A	Gasket – Hydraulic Motor Adapter	1	383940	383940
28A	Capscrew – Hydraulic Motor Adapter / Head	4	920369	920369
34	Coupling w/ Setscrew – for straight key hyd. motor shaft	1	906967	906966
35	Key – Coupling	1	909184	N/A
76	Grease Fitting	1	317815	317815
76A	Grease Relief Fitting	1	701992	701992
135	Hydraulic Motor Adapter – SAE A Flange	1	041828	041827
135A	Capscrew – Adapter / Motor	2	920510	920510

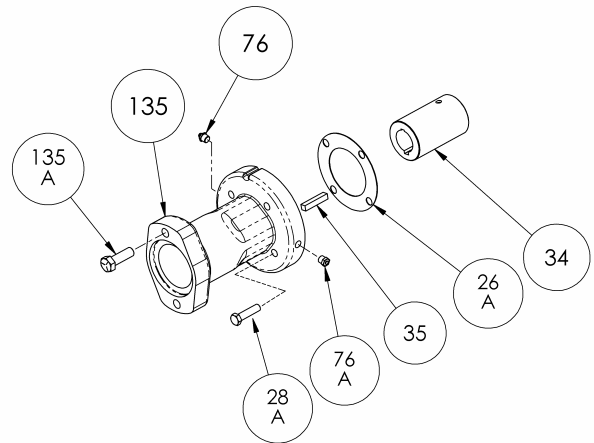

* Hydraulic Motor Adapter Kits shipped prior to Spring 2002 were of a two piece design – refer to page 206-B00.



1809 Century Avenue, Grand Rapids, Michigan 49503-1530, U.S.A.
Telephone: (616) 241-1611 / Fax: (616) 241-3752
E-Mail: blackmer@blackmer.com / Internet: www.blackmer.com

Parts List 201-A02
Page 2 of 2