

BLACKMER PARTS LIST

PUMP MODELS: TXD3E, TXSD3E (Double Ended Shafts)
TX3E, TXS3E (Single Ended Shafts)

See Instructions 201-A00 for Installation, Operation and Maintenance

961815
Page 1 of 2

PARTS LIST
201-A04

Section 201
Effective Sept 2007
Replaces Jan 2007

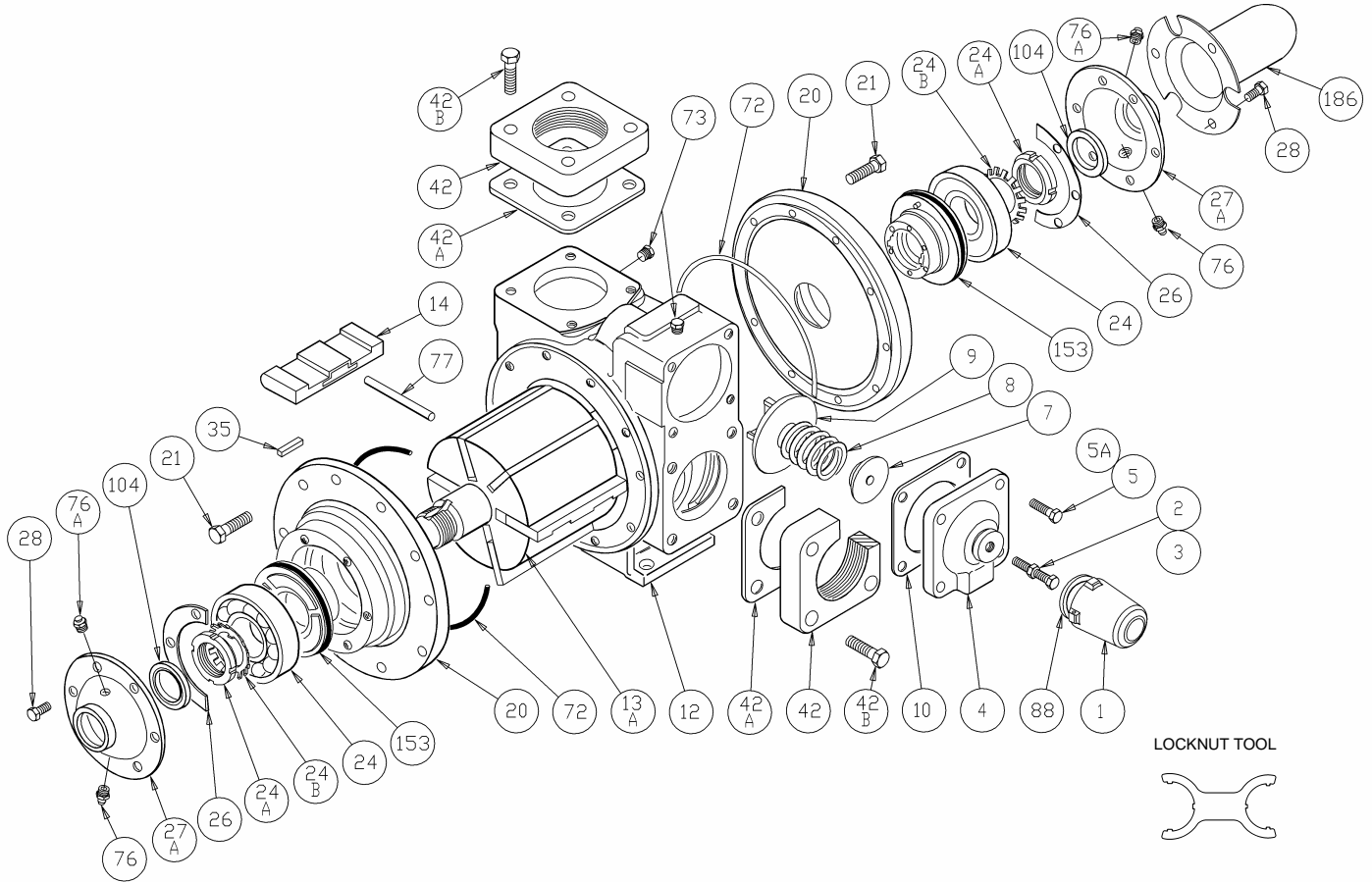

Ref. No.	Description	Parts Per Pump	Part No.	Ref. No.	Description	Parts Per Pump	Part No.
1	Cap - Relief Valve (R/V)	1	413957	27A	Bearing Cover	1 - 2	041815
2	Adjusting Screw - R/V	1	431808		Bearing Cover - Outboard	0 - 1	041817
3	Locknut - Adjusting Screw	1	922923	28	Capscrews - Bearing Cover	12	920285
4	Cover - R/V	1	411807	35	Key - Shaft	1	909178
5	Capscrew - R/V Cover	3	920331	42	Flange - 3" NPT	1 - 2	651803
5A	Capscrew w / Hole - R/V Cover	1	920330	42	Flange - 3" Weld	1 - 2	655102
7	Spring Guide - R/V	1	421805	42A	Gasket - Flange	2	381816
8	Spring - R/V (51-110 psi)(Std.)	1	471806	42B	Capscrew - NPT Flange	4 - 8	920532
	Spring - R/V (111-125 psi)		471809		Capscrew - Weld Flange		920510
9	Valve - R/V (Std. TXD)	1	451807	72	O-Ring - Head (Buna-N) (Std. TXD)		701944
	Valve - R/V (Nickel Plated) (Std. TXSD)		451808		O-Ring - Head (FKM) (Std. TXSD)	2	711938
10	Gasket - R/V Cover	1	531803		O-Ring - Head (PTFE)		702233
12	Cylinder	1	021805	73	Gage Plug	2	908198
13A	Rotor & Shaft Asy. - Double Ended ²	1	261837	76	Grease Fitting	2	317815
	Rotor & Shaft Asy. - Single Ended ²		261839	76A	Grease Relief Fitting	2	701992
14	Vane - Duravane	6	091819	77	Push Rod	3	121807
20	Head	2	031815	88	Gasket - R/V Cap	1	533908
21	Capscrews - Head	20	920369	104	Grease Seal	1 - 2	331908
24	Ball Bearing	2	903172	186	Shaft Protector	0 - 1	341801
24A	Locknut - Bearing	2	903523		Air Valve Kit		891798
24B	Lockwasher - Bearing	2	903524		Tool - Locknut		903091
26	Gasket - Bearing Cover	2	381817		Kit - Maintenance (TXD3E only)		898952

¹ Included in Maintenance Kit ² Includes ref. Nos. 24A & 24B

Keep this parts list with Installation, Operation and Maintenance Instructions.

MECHANICAL SEALS

REF. NO.	PART NAME	PARTS PER PUMP	PART NO.
153	Mechanical Seal Complete - Std. TXD Cast Iron Stationary Seat, Carbon Seal Face, Buna-N O-Rings. (INCN)	2	¹ 331880
	Mechanical Seal Complete - Std. TXSD Cast Iron Stationary Seat, FKM O-Rings, Carbon Seal Face. (IVCV)		331883
	Mechanical Seal Complete - Cast Iron Stationary Seat, PTFE O-Ring, Carbon Seal Face w/ PTFE Seal Ring. (IACT)		331873
153D	O-Ring - Stationary (Buna-N)	2	701936
	O-Ring - Stationary (FKM)		711931
	O-Ring - Stationary (PTFE)		702080
153L	O-Ring - Rotating (Buna-N)	2	711912
	O-Ring - Rotating (FKM)		701962
	Seal Ring - Rotating (PTFE)		**

¹ Included in Maintenance Kit

** PTFE Rotating Seal Ring is not available as a separate part.

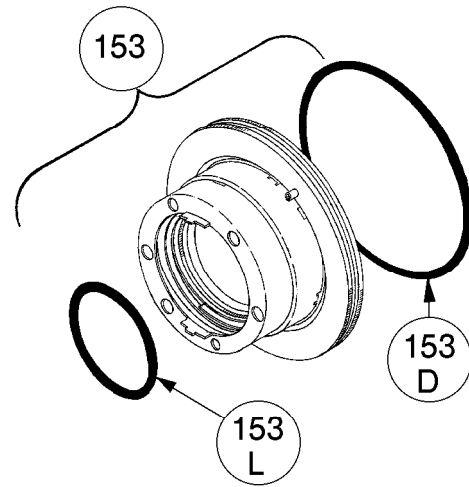

OPTIONAL HYDRAULIC MOTOR ADAPTER PARTS

REF. NO.	PART NAME	PARTS PER PUMP	PART NO.
	Hydraulic Motor Adapter Kit *		895140
26A	Gasket – Hydraulic Motor Adapter	1	381817
28A	Capscrew – Hydraulic Motor Adapter / Head	6	920369
34	Coupling w/ Setscrew – for 1.25" straight key hydraulic motor	1	906967
35	Key – Coupling	1	909184
76	Grease Fitting	1	317815
76A	Grease Relief Fitting	1	701992
135	Hydraulic Motor Adapter – SAE A Flange	1	041831
135A	Capscrew – Adapter / Motor	2	920510

* Hydraulic Motor Adapter Kits shipped after Spring 2002 were of a two piece design – refer to page 206-B00.

