

BLACKMER PARTS LIST

PUMP MODEL: X2.5B

Section 101
Effective Sept 2007
Replaces Dec 2006

See Instructions 101-B00 for Installation, Operation and Maintenance

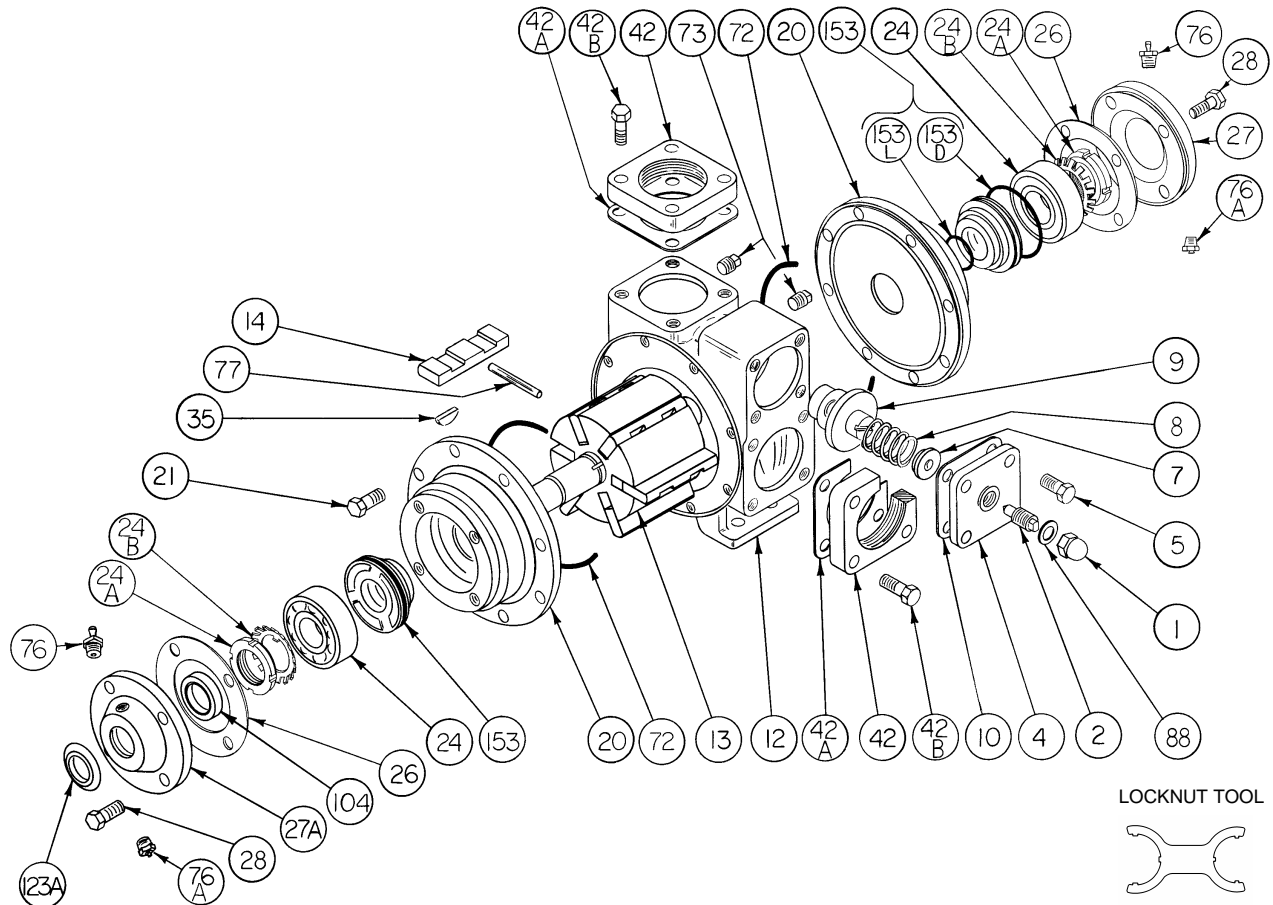

Ref. No.	Description	Parts per Pump	Part No.	Ref. No.	Description	Parts per Pump	Part No.
1	Cap - Relief Valve (R/V)	1	411452	24	Ball Bearing	2	903156
2	Adjusting Screw - R/V	1	431401	24A	Locknut - Bearing	2	903521
4	Cover - R/V	1	411607	24B	Lockwasher - Bearing	2	903522
5	Capscrew - R/V Cover	4	920316	26	Gasket - Bearing Cover	2	383940
7	Spring Guide - R/V	1	423955	27	Bearing Cover - Outboard	1	041433
8	Spring - R/V (41-50 psi)**	1	471608	27A	Bearing Cover - Inboard	1	041431
	Spring - R/V (51-110 psi)		471631	28	Capscrews - Bearing Cover	8	920285
	Spring - R/V (111-125 psi)		471614	35	Key - Shaft	1	909130
9	Valve, R/V (41-50 psi)**	1	451609	42	Flange - 2 1/2" NPT (Std.)*	2	651611
	Valve, R/V (51-125 psi) (Std.)		451623	42A	Gasket - NPT Flange (Std.)	2	381650
	Valve, R/V (51-125 psi) (Nickel Plated)		451624	42B	Capscrews - NPT Flange (Std.)	8	920532
10	Gasket - R/V Cover	1	531603	72	O-Ring - Head (FKM) (Std.)	2	701914
12	Cylinder	1	021605		O-Ring - Head (PTFE)		702242
13	Rotor & Shaft Assembly	1	261667	73	Gage Plug	2	908198
	EC Rotor & Shaft Assembly (Both R/S Include Ref. No. 24A & 24B)		261669	76	Grease Fitting	2	317815
14	Vane - Duravane (Std.)	6	091619	76A	Grease Relief Fitting	2	701992
	Vane - EC Cast Iron		091621	77	Push Rod	3	121607
	Vane - EC Laminate		091627	88	Gasket - R/V Cap	1	701981
20	Head	2	031425	104	Grease Seal	1	331918
21	Capscrews - Head	16	920331	123A	Dirt Shield	1	701480
					Tool - Locknut		903091
					Kit - Maintenance		898957

Keep this parts list with the Installation, Operation and Maintenance Instructions. * Included in Maintenance Kit
 * See Page 2 for Weld / ANSI flange options. SS = Stainless Steel. EC = Extra-Clearance.
 ** R/V Spring p/n 471608 and Valve p/n 451609 MUST be used together to achieve listed pressures.

MECHANICAL SEALS

Ref. No.	Part Name	Parts Per Pump	Part No.
153	Mechanical Seal Complete - (Std.) Cast Iron Stationary Seat, Carbon Seal Face, FKM O-Rings. (IVCV)	2	¹ 331655
	Mechanical Seal Complete - Cast Iron Stationary Seat, PTFE O-Ring, Carbon Seal Face w/ PTFE Seal Ring. (IACT)		331673
153D	O-Ring - Stationary (FKM)	2	701921
	O-Ring - Stationary (PTFE)		702056
153L	O-Ring - Rotating (FKM)	2	701980
	Seal Ring - Rotating (PTFE)		**

¹ Included in Maintenance Kit

** PTFE Rotating Seal Ring is not available as a separate part.

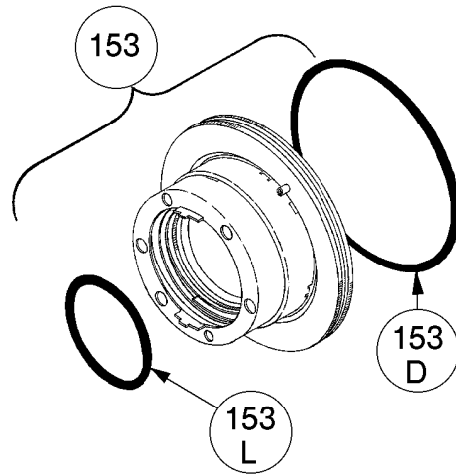

FLANGE OPTIONS

Ref. No.	Part Name	Parts Per Pump	Part No.
42	Flange - 2 1/2" Weld	2	651610
	Flange - 3" ANSI		651617
42B	Capscrews - Weld / ANSI Flange	8	920491
42C	O-Ring - Weld/ANSI Flg. (FKM)	2	701924
	O-Ring - Weld/ANSI Flg. (PTFE)		702079

