

# BLACKMER PARTS LIST

## PUMP MODELS: XLW2F, XLW3F

### DISCONTINUED MODELS: XLW2E-N, XLW3E-N

See Instructions 105-B00 Installation, Operation and Maintenance

Section | 105  
Effective | Sept 2007  
Replaces | Mar 2005

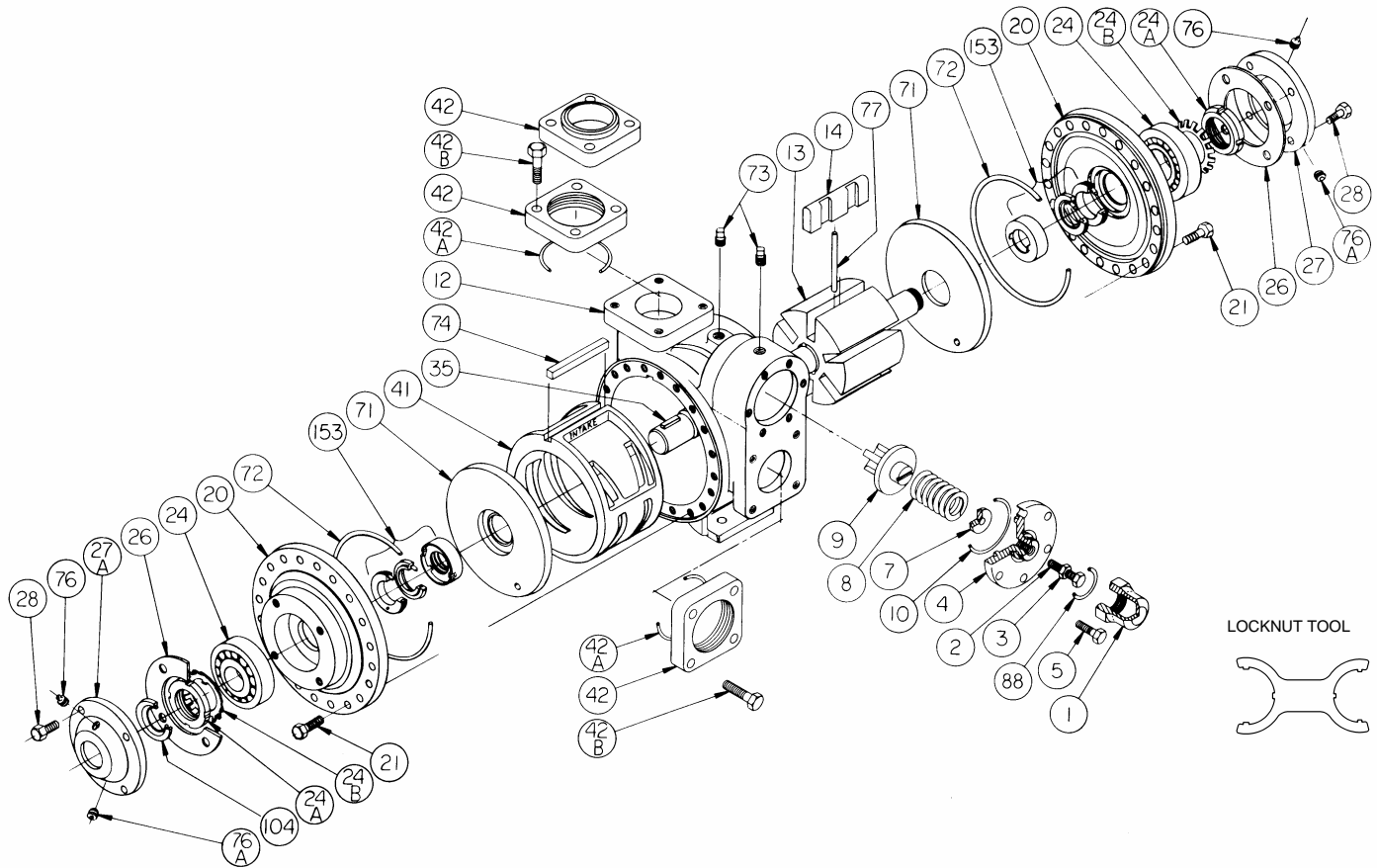

Ref. No.	Description	Parts per Pump	Size 2 Part No.	Size 3 Part No.	Ref. No.	Description	Parts per Pump	Size 2 Part No.	Size 3 Part No.
1	Cap – Relief Valve (R/V)	1	414402	414402	26	Gasket – Bearing Cover	2	<sup>1</sup> 383940	<sup>1</sup> 385125
2	Adjusting Screw – R/V	1	433905	435109	27	Bearing Cover – Outboard	1	041433	041817
3	Locknut – Adjusting Screw	1	922923	922923	27A	Bearing Cover – Inboard	1	041431	041815
4	Cover – R/V	1	414408	415109	28	Capscrews – Bearing Cover	8-12	920285	920285
5	Capscrew – R/V Cover	6	920316	920331	35	Key – Shaft	1	<sup>1</sup> 909130	<sup>1</sup> 909130
7	Spring Guide – R/V	1	424401	425109	41	Liner	1	<sup>2</sup> 183913	<sup>2</sup> 185116
8	Spring – R/V (51-75 psi) (Std.)	1	471425	471612	42 <sup>4</sup>	Flange – NPT	2	654401	655112
	Spring – R/V (76-110 psi)		471428	471621		Flange – Weld		654405	655102
	Spring – R/V (111-150 psi)		471430	475109	42A	O-Ring – Flange (FKM)	2	<sup>1</sup> 702086	<sup>1</sup> 711931
9	Valve – R/V	1	454405	455109	42B	Capscrew – NPT Flange	8	920384	920547
10	O-Ring – R/V Cover (FKM)	1	<sup>1</sup> 711929	<sup>1</sup> 701924	Capscrew – Weld, ANSI	920351		920510	
12	Casing	1	014405	015127	71	Disc	2	<sup>2</sup> 063900	<sup>2</sup> 065114
13	EC Rotor & Shaft Assy. (-.045) (Std)	1	<sup>2</sup> 263927	<sup>2</sup> 265143	72	O-Ring – Head (FKM)	2	<sup>1</sup> 702045	<sup>1</sup> 711938
	FS Rotor & Shaft Assy. (Both Include Ref. 24A & 24B)		263923	265204	73	Gage Plug	2	908195	908195
14	Vane – EC Hardened Iron (Std.)	6	<sup>1</sup> 093931	<sup>1</sup> 095129	74	Key – Liner	1	<sup>2</sup> 183991	<sup>2</sup> 185191
	Vane – EC Laminate		091429	095107	76	Grease Fitting	2	317815	317815
20	Head	2	034416	035128	76A	Grease Relief Fitting	2	701992	701992
21	Capscrews – Head	32-40	920351	920369	77	Push Rod	3	<sup>1</sup> 123905	<sup>1</sup> 125105
24	Ball Bearing	2	<sup>1</sup> 903156	<sup>1</sup> 903172	88	O-Ring – R/V Cap (FKM)	1	<sup>1</sup> 701979	<sup>1</sup> 701979
24A	Locknut – Bearing	2	903521	903523	104	Grease Seal	1	<sup>1</sup> 331918	<sup>1</sup> 331908
24B	Lockwasher – Bearing	2	<sup>1</sup> 903522	<sup>1</sup> 903524		Tool - Locknut		903091	903091
						Kit - Maintenance		898974	898975
						Kit - Rebuild		899074	899075

<sup>1</sup> Included in Maintenance Kit and Rebuild Kit

<sup>2</sup> Included in Rebuild Kit

<sup>4</sup> See more flanges on backside.

Keep this parts list with Installation, Operation and Maintenance Instructions.

EC = Extra Clearance

FS = Full Size

**MECHANICAL SEALS**

Ref. No.	Part Name	Parts Per Pump	Size 2 Part No.	Size 3 Part No.
153	Mechanical Seal Complete – (Std.) Silicon Carbide Stationary Seat, Hardened Steel Seal Face, FKM O-Rings. (LVSV)	2	<sup>1</sup> 333919	<sup>1</sup> 335147
	Mechanical Seal Complete – Silicon Carbide Stationary Seat, Hardened Steel Seal Face, PTFE O-Rings. (LAST)		333922	335150
	Mechanical Seal Complete – Silicon Carbide Stationary Seat, Silicon Carbide Seal Face, FKM O-Rings. (LVLV)		333921	335149
153A #	Stationary Seat (Silicon Carbide)	2	334422	335141
153B #	Rotating Seal Face (Hardened Steel)	2	333917	335144
	Rotating Seal Face (Silicon Carbide)		333916	335198
153C #	Jacket Assembly	2	331651	335128
153D	O-Ring – Stationary (FKM)	2	701970	702015
	O-Ring – Stationary (PTFE)		702084	711999
153E	O-Ring – Rotating (FKM)	2	701980	701962
	Seal Ring – Rotating (PTFE)		711963	701963

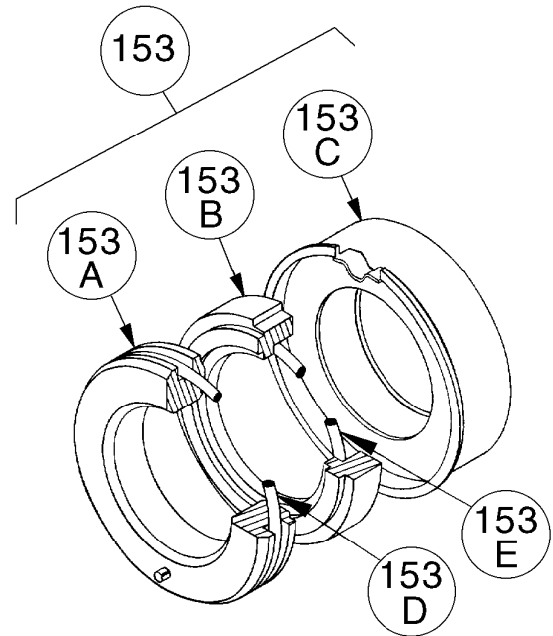

<sup>1</sup> Included in Maintenance Kit and Rebuild Kit

# These components are included in the complete mechanical seal assemblies (Ref. No. 153), and are NOT available as replacement parts. Consult factory.

**FLANGE OPTIONS**

Ref. No.	Part Name	Parts Per Pump	Size 2 Part No.	Size 3 Part No.
42	Flange – ANSI 2" 150 lb. R.F.	1-2	651417	---
	Flange – ANSI 3" 150 lb. R.F.		---	651817

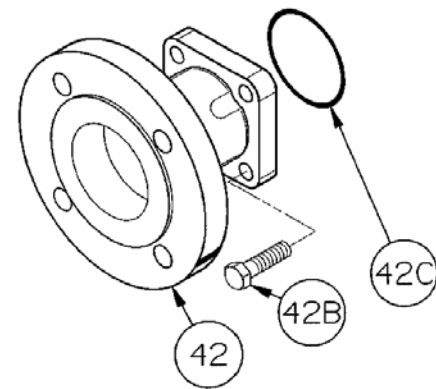

ANSI FLANGE

