

Telephone 800-500-9311
Telephone 864-573-9200
Fax 864-573-9299

OEC FLUID HANDLING INC.

SUBSIDIARY OF OILMEN'S EQUIPMENT CORP.
www.oecfh.com

140 Cedar Springs Rd.
P. O. Box 2807
Spartanburg, SC 29304

■ Stocked Items 11/06/03

PD Pumps

- ARO Ingersoll-Rand
- Blackmer Vane
Blackmer/Abaque Peristaltic
Blackmer "C" Eccentric Disc
- Alfa Laval-TriClover Lobe
- APV Lobe
- Tuthill Gear
Tuthill Lobe
MonoFlo Progressive Cavity

Centrifugal Pumps

- Alfa Laval-TriClover Sanitary
- APV Crepaco
- Deming End Suction
Deming Vertical Turbine
- Griswold ANSI Pumps
- MP Pump

Specialty Pumps

Flux Drum

Petroleum-Fuel Pumps

- Gorman-Rupp
- Dresser Wayne Corp
- Red Jacket
Graco
William Wilson Gasboy

Hand Pumps

- Blackmer
- Tokhiem
- Tuthill Fill-Rite

Storage Tanks

Stainless Steel ASME
UL & ASME Carbon Steel
Fiberglass Tanks
Chem-Tainer Poly Tanks
Assmann Poly Tanks
Snyder Poly Tanks

Tank Fittings & Vents

- OPW Engineered Systems
EMCO Wheaton
Morrison Bros
Protectoseal

Mechanical Seals

Utex

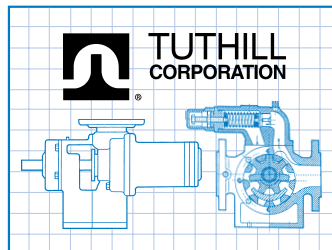
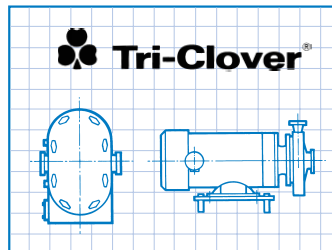
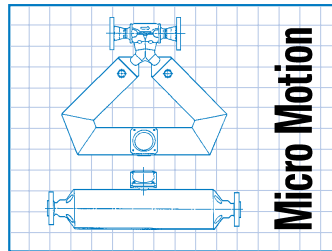
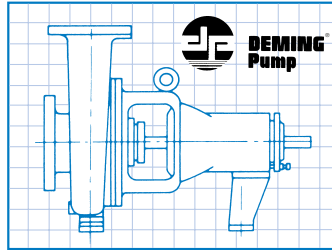
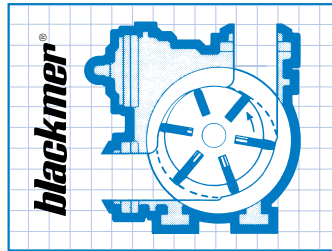

Meters & Instrumentation

- Micro Motion Coriolis
- Neptune Actaris PD
- Tuthill FPP PD
- Liquid Controls PD
Halliburton Turbine
Rosemount
Pressure Transmitters
Flow Transmitters
Temperature Transmitters
Level Transmitters

Sanitary Products

- Alfa Laval-TriClover Pumps
- Alfa Laval-TriClover Fittings
Alfa Laval-TriClover Valves
APV Pumps
APV Valves
APV Homogenizers
B & A Flexible Sanitary Hose

Liquid Level Gauges

- Protectoseal
Pneumercator
Moorman Bros
Milltronics/Siemens
Rosemount Level Transmitters

Hose & Reels

- Goodyear Hose
- Hannay Reels
Lawrence Composite Hose

Filters

Filtration Group Bag Filters

Mixers

Brawn Portable & Sanitary
Proquip Top Entry Agitators

Liquid Loaders & Platforms

OPW Engineered Systems
Green Manufacturing

Rotary Unions

Deublin

Custom Liquid Systems

For liquid transfer, batching &
process metering

Performance Guaranteed

CHARLOTTE, NC ■ SPARTANBURG, SC ■ GREENSBORO, NC

INSTRUCTION MANUAL

Revised: November 11, 2003

MODEL LC1000 INTRINSICALLY SAFE ALARM CONSOLE



© COPYRIGHT 2003 PNEUMERCATOR CO.
120 FINN COURT, FARMINGDALE, N.Y. 11735
(631) 293-8450 Phone
(631) 293-8533 Fax
(800) 209-7858 Product Support
www.pneumercator.com

Operation and Installation Manual

TABLE OF CONTENTS

DESCRIPTION

General 1
 Control Console 1
 Field Sensors 1
 Specifications 2
 Dimensions 3

INSTALLATION 4

Typical Sensor Mountings 6
 Installation Diagram for Hazardous Locations 7
 PC Board Layout and Controls 8

OPERATION

General 9
 Relay Operation 9
 Horn Control 9
 Test Modes 10
 Manual Test Float Switch 11

IMPORTANT

Installation of this equipment must be in accordance with these instructions as adopted from the following codes:

- ISA RP12.6, "Installation of Intrinsically Safe Instrument Systems in Class I Hazardous Locations"
- NFPA 70, "National Electric Code"

Alteration, modification or replacement with non-factory components could impair the intrinsic safety of this equipment.

Operation and Installation Manual

DESCRIPTION

GENERAL

The basic function of the Model LC1000 Alarm console is to provide both audible and visual warning alarms at the occurrence of high or low process conditions: Typically via high/low level switches, or any tank mounted sensing device that transmits an alarm condition by opening or closing dry switch contacts. Secondary leak containment may also be provided via dry contact leak switches. The console is powered by 120 VAC and provides from 1 to 4 input channels, each consisting of a pair of intrinsically safe terminals for wiring to field mounted switches. The intrinsically safe inputs allow mounting the switches in explosion hazard environments without requiring additional protective barrier components in the wiring runs.

CONTROL CONSOLE

The console is housed in a NEMA 4 (weathertight) enclosure for mounting in the non-hazardous area. Each unit operates on 120 VAC power and provides from one (1) to four (4) intrinsically safe alarm channels for monitoring up to four independent sensing points. The electrical energy output at each channel is 12 VDC at 15 mADC maximum, and is zener barrier protected. Bright red incandescent alarm lights and a loud sounding horn are mounted to the enclosure cover. Each alarm channel is equipped with an output relay, totally isolated from the sensor inputs, rated for SPDT-3 amps, for controlling external devices such as pumps, valves or remote alarm annunciators. All field wiring is made through pressure-type terminal blocks enclosed under metal barriers to separate the power from the intrinsically safe wiring

FIELD SENSORS

The standard sensor used with the LC1000 console is the Pneumercator Model Series LS600 float level switch. The LS600 consists of from one (1) to four (4) magnetic floats mounted on a brass or stainless steel tube suspended into the top of a liquid storage tank. Each float actuates a reed switch, which is hermetically sealed within the suspension tube, when the liquid level rises or falls past the float. The reed switch is a pair of dry contacts either normally open or normally closed, rated at 3 amps. Other types of field switches (pressure, temperature, flow, etc.) may be wired to the LC1000 alarm consoles, providing they are purely mechanical devices, (non-electrical energy storing).

Operation and Installation Manual

SPECIFICATIONS

Model LC1000 Alarm Console

Power Input:
120 VAC ±10%, 60 Hz
Fuse 0.1A, 3AG SLO-BLO

Power to Field Sensor:
Low electrical energy: 12 VDC at 15 mA provided by control unit to each sensor switch, Safe for Class I, Division 1, Groups A,B,C,D

Control Relay Output
Dry switch contact—SPDT per point, rated 3 AMPS at 120 VAC; selectable either normally open or normally closed.

Response Time
Typically ½ second. Automatic horn silence option, adjustable 30 seconds to 3 minutes.

Indicators / Controls:
Red light indicates alarm condition. Horn signals audible alarm—85dB min. Reset button silences alarm. Test button tests alarm circuits.

Temperature:
-40°F to +160°F (-40°C to +71°C)

Enclosure:
NEMA 4—weatherproof standard

Installation:
Wall mount standard

Weight:
6 lbs. (2.7 kg.) approx.—small case
11 lbs. (5 kg.) approx.—large case

Sensor Cable:
Standard 2 conductor #18 AWG
Up to 5000 feet (by customer)

Model Number Schedule

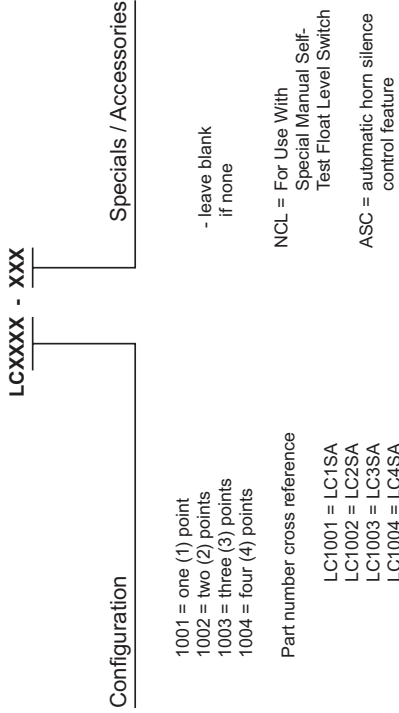

MODEL LS 600 FLOAT LEVEL SWITCH

REPEATABILITY: 1/8 inch typical per point.

TEMPERATURE: -20° to +180° F. (-28° to +82° C)

PRESSURE: Full vacuum to 150 PSIG.

CONSTRUCTION: Per Model Number Schedule at right.

SWITCH RATING: Reed Type rated 3 amps either Normally Open or Normally Closed.

System Approval: Factory Mutual approved intrinsically safe with entity for Class I, Division 1, Groups A,B,C,D; Class II, Division 1, Groups E & G.

MODEL NUMBER SCHEDULE

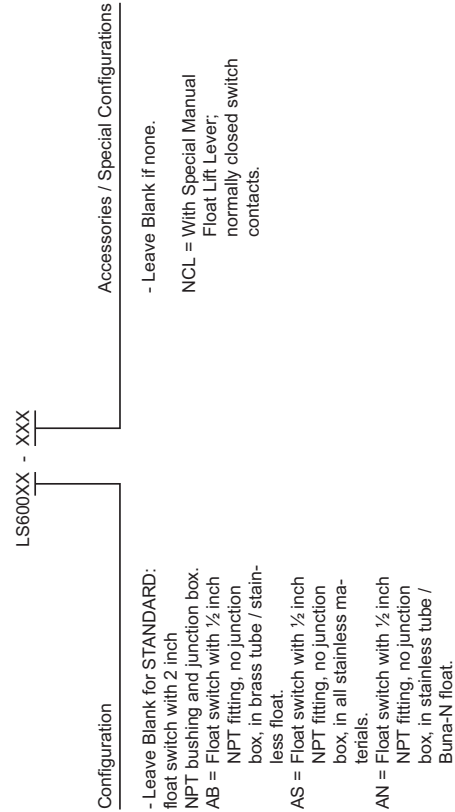

Operation and Installation Manual

DIMENSIONS

MODEL LC1000 ALARM CONSOLES

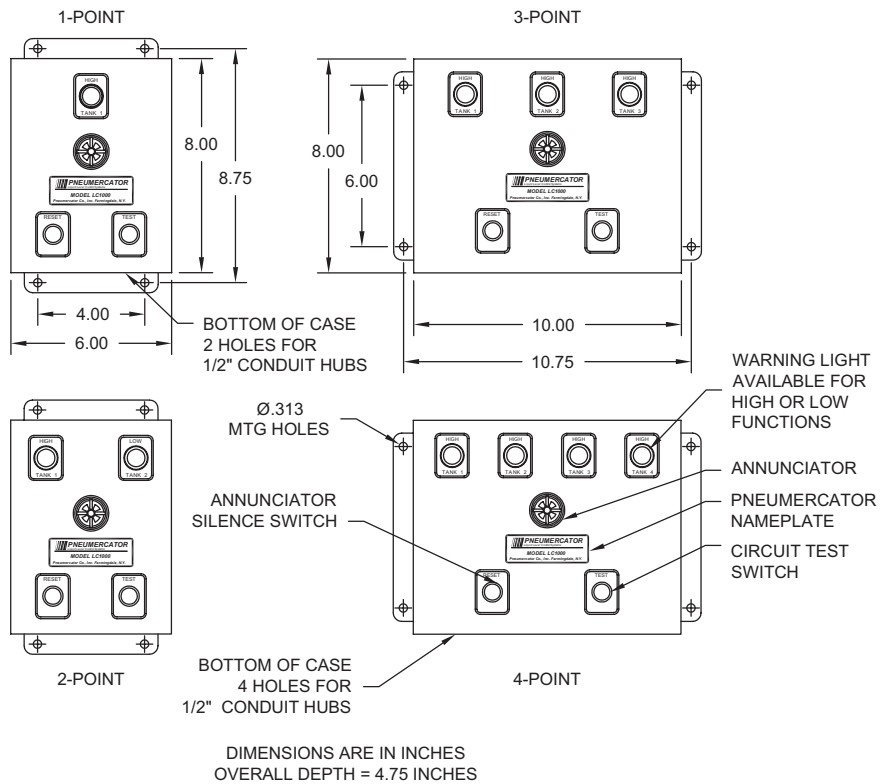

MODEL LS600 FLOAT LEVEL SWITCHES

LS600A -BASIC UNIT

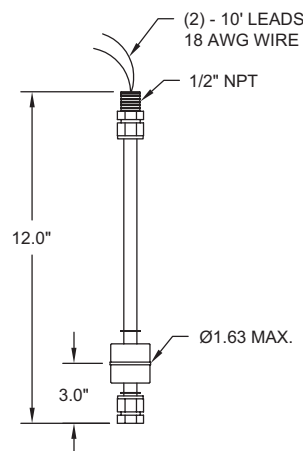

LS600-UNIT WITH JUNCTION BOX

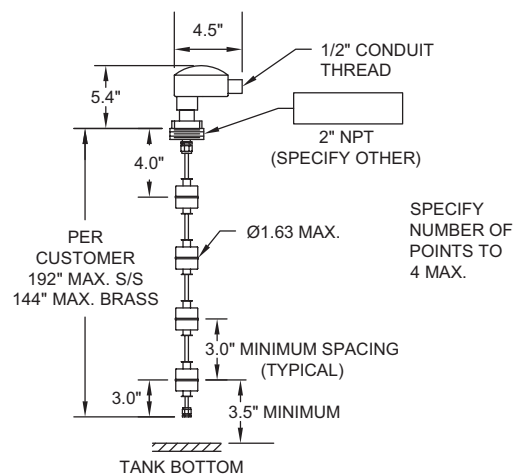

Operation and Installation Manual

INSTALLATION

NOTE: INSTALLATION SHOULD BE DONE BY QUALIFIED PERSONNEL, FAMILIAR WITH LOCAL WIRING CODES AND EXPLOSION HAZARD ELECTRICAL SAFETY PRACTICES.

GENERAL

The LC1000 Consoles are designed for mounting outdoors, but not within the hazardous area containing explosive vapors. It is important that all wiring connections are made through weatherproof liquid tight conduits at the console and at the field sensors. In addition, if the field sensors are located in an explosive hazard area, the conduits must be fitted with suitable vapor tight seals.

SENSOR INSTALLATION

The following procedure is for mounting Pneumercator Model LS600 Float Level Switches, but is typical for any float-actuated or mechanical type switch not requiring external electrical power. When installing other field sensors intended for connection to the LC1000 intrinsically safe equipment, consult that manufacturer's installation instructions.

1. Model LS600 sensors are available with various length shafts, from 12" through 240", and with up to four floats. Each float position is fixed to travel within only ½ inch around the desired level set-point, as originally specified by the customer. The float is not adjustable. Do not attempt to re-position it.
2. Refer to the Sensor Installation Drawing, Figure 1, to select the appropriate mounting method to suit the installation. Note that the minimum tank opening is 2" NPT to pass the float through. Follow this mounting method for all level switches to be connected to the LC1000 console - maximum of 4 sensors per console. Use pipe compound on all threads.
3. Run 2 wires (18 gauge stranded) for each sensor through suitable junction boxes and ½" weatherproof liquid tight conduit. All sensor wiring may be run through a common conduit providing the conduit contains no other wiring. Failure to observe this will impair the intrinsic safety of the system. Refer to wiring diagram, Figure 2.
4. At the sensor end, connect each 2-wire pair to the respective sensor wire pair using suitable size wire nuts. Seal the conduit against water entering the junction boxes and gas vapor from propagating back to the alarm console. Do not connect the wires to the terminal block in the alarm console yet. Proceed with "[Alarm Console Installation](#)".

ALARM CONSOLE INSTALLATION

Select a location for the console, which is as close as practical to, but outside of the explosion hazard area and within eyesight and hearing of the person(s) responsible for responding to the level alarm condition. The unit is weathertight and may be mounted outdoors. Refer to the dimensional data, Page 3 and Wiring, Figure 2.

Operation and Installation Manual

- 1 Mount the console at the location selected using the four (4) holes provided on the enclosure mounting flanges.
2. Attach weathertight conduit(s) for power and all sensors to the enclosure through the bottom entrance holes provided. These are for ½" NPT pipe or rigid conduit. Sensor conduits to left side, power and relay output contacts - single conduit - to right side of enclosure.
3. Run three (3) power wires - Hot, Neutral and Ground - plus any relay dry contact control wires* - maximum of 3 per sensing point - through the single "Power" conduit connected to the bottom right side enclosure hole.
4. The alarm console is separated into two wiring sections, for each printed circuit board, by an aluminum cover. The wiring and terminal block on the left side are intrinsically safe and are physically separated from the AC power wiring on the right side. This separation must be maintained. Remove the protective cover by loosening the two hold-down screws.
5. Strip insulation from the ends of all wires and pull them into the alarm console. Connect all wires to the proper terminals according to the wiring diagram, Figure 2. The terminal blocks may be removed for ease of wiring by pressing with your finger down toward the conduit openings. Note that for multiple channel consoles, power need only be wired to the right hand circuit board.
6. Properly dress all wires inside the wiring sections and re-install the protective aluminum cover over the terminals.

Important

Connect a 12 A.W.G. (minimum conductor size) copper wire from either one of the cover hold down screws or the sensor terminal marked "Earth Ground" (left side of either circuit board) to a good earth ground. The ground connection must be within 1 OHM of true ground and must be made at only one point for the system to maintain intrinsic safety.

7. Securely clamp down the enclosure door and tighten all conduit entrances to seal the system watertight. Install vapor seals in accordance with local codes for hazardous locations if applicable.
-

* The relay dry contacts for each alarm channel are supplied without any connections to power. It is necessary to connect a power source - typically 120 VAC - to the relay contacts in order to provide power to the external device being controlled by the alarm console. See Table 1 for relay dry contacts schedule.

Operation and Installation Manual

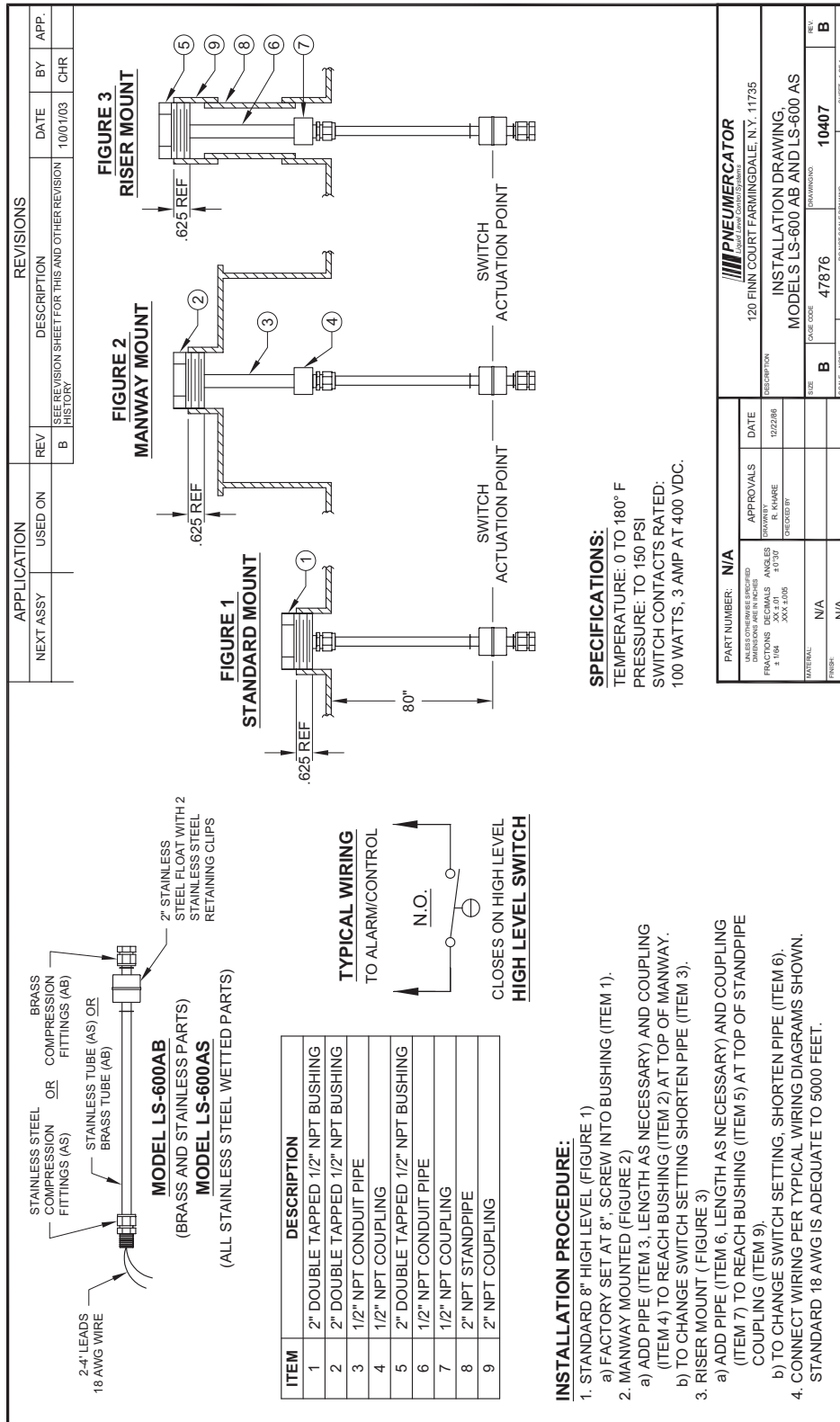

Figure 1 - LS600A Sensor Installation Drawing

Operation and Installation Manual

ITEM	FUNCTION																																																
TB1 TB2	Sensor Terminal Block Power and Relay Contact Terminal Block Note that the circuit board labeling refers to the de-energized state of the relay.																																																
TB3 F1	Intrinsic Safety Ground Terminal Power Fuse: 0.1 Amp, Slo-Blow 3AG																																																
JP3-JP6 (Jumper Plugs)	Relay Control Jumper Plug Schedule / Each PC Board																																																
	<table border="1"> <thead> <tr> <th colspan="2">Field Sensor Normal condition</th> <th colspan="4">Jumper Position on PC Board</th> <th colspan="6">Dry Contacts Output at Terminal Block TB2*</th> </tr> <tr> <th>Input 1</th> <th>Input 2</th> <th>JP3</th> <th>JP4</th> <th>JP5</th> <th>JP6</th> <th>1</th> <th>2</th> <th>3</th> <th>4</th> <th>5</th> <th>6</th> </tr> </thead> <tbody> <tr> <td>N. Open</td> <td>N. Open</td> <td>A-B</td> <td>D-E</td> <td>U-V</td> <td>X-Y</td> <td>CL</td> <td>C</td> <td>OP</td> <td>CL</td> <td>C</td> <td>OP</td> </tr> <tr> <td>* N. Closed</td> <td>N. Closed</td> <td>A-C</td> <td>D-F</td> <td>U-W</td> <td>X-Z</td> <td>OP</td> <td>C</td> <td>CL</td> <td>OP</td> <td>C</td> <td>CL</td> </tr> </tbody> </table>	Field Sensor Normal condition		Jumper Position on PC Board				Dry Contacts Output at Terminal Block TB2*						Input 1	Input 2	JP3	JP4	JP5	JP6	1	2	3	4	5	6	N. Open	N. Open	A-B	D-E	U-V	X-Y	CL	C	OP	CL	C	OP	* N. Closed	N. Closed	A-C	D-F	U-W	X-Z	OP	C	CL	OP	C	CL
Field Sensor Normal condition		Jumper Position on PC Board				Dry Contacts Output at Terminal Block TB2*																																											
Input 1	Input 2	JP3	JP4	JP5	JP6	1	2	3	4	5	6																																						
N. Open	N. Open	A-B	D-E	U-V	X-Y	CL	C	OP	CL	C	OP																																						
* N. Closed	N. Closed	A-C	D-F	U-W	X-Z	OP	C	CL	OP	C	CL																																						
	* Failsafe relay operation is provided with N. Closed Field Sensor Inputs. In this mode, relays will be energized in normal mode; de-energized in alarm mode. Note that the circuit board labeling refers to the de-energized state of the relay.																																																
JP7	Automatic Horn Silence Jumper Plug. Remove on each PC Board to disable Automatic Horn Silence feature. Insert plug to enable feature for selected PC board, then adjust R14.																																																
R14	Automatic Horn Silence Time Delay control. Turn counterclockwise with small-slotted screwdriver to increase horn shutoff time. Minimum delay is 30 seconds. Maximum is 3 minutes.																																																
S-T, P-R	External Horn reset jumpers. (see page 10)																																																

*C=Common, CL=Closed Contact, OP=Open Contact

Table 1 - Board Settings

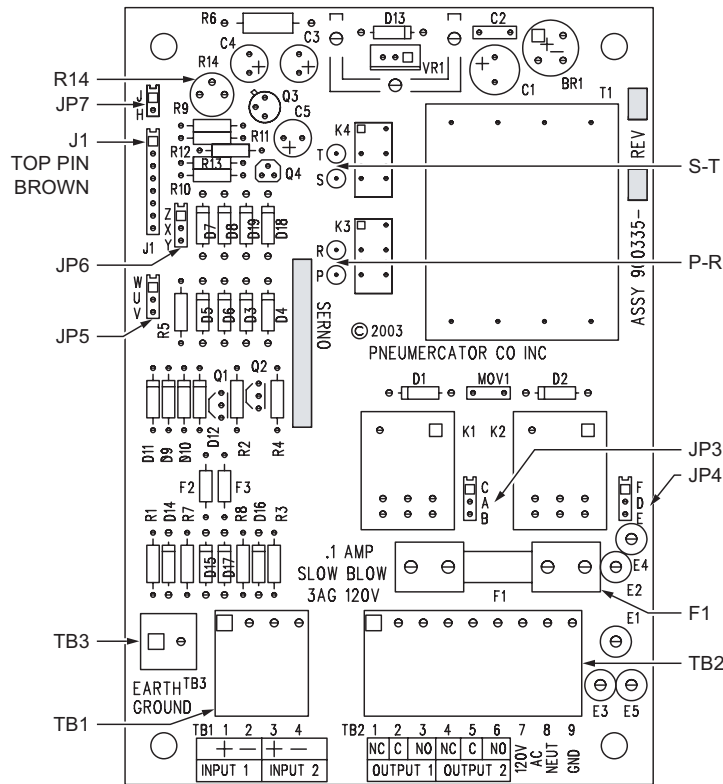

Figure 3 - PC Board Layout

Operation and Installation Manual

OPERATION

GENERAL

The LC1000 Alarm system provides three (3) functions when a field sensor experiences an alarm condition: A light comes on, a horn annunciates and a relay changes over dry contacts. The horn may be silenced by pressing the "reset" button, but the light will stay on as long as the field sensor remains in the alarm condition, e.g., high liquid level. After the alarm condition is corrected, i.e., lowering the liquid level below the level switch setting, the alarm light will extinguish, and the horn will automatically reset to the silent state. On multiple sensor consoles, each input channel - sensor - will actuate the horn and its respective light independent of the other sensors' state or the prior state of the alarm console. The "Test" button manually energizes the horn and all lights on the console.

OUTPUT RELAY DRY CONTACTS

Relay contacts for status indicators or other external control devices – pumps, valves, annunciators, etc. - are provided for each channel, rated for 3 amps at 120 VAC, SPDT.* They are "dry", un-powered, requiring connection to a power source to control external devices. Each alarm circuit board can be set to operate on normally open or normally closed field sensors. This is accomplished by placing the "jumper-plugs" across the selected pins according to the schedule on the PC board layout, Figure 3. The standard factory set-up is for each relay to "energize" when its respective field sensor switches from "Normally Open" to Closed upon an alarm condition. It is important to know what operating sequence is needed before wiring the output relay contacts to external devices. The dry contact arrangement is shown on the PC board layout and the wiring diagrams.

HORN CONTROLS

In addition to silencing the horn by pressing the "Reset" button, four other horn controls are available:

-Loudness Level - A louver on the horn face may be adjusted by hand to decrease the output sound from about 92 decibels to about 50 decibels.

-Automatic Silence (Optional) - A potentiometer on the PC board (see Figure 3 - PC Board layout) allows selecting a time delay interval after which the horn will silence automatically, without pressing the "reset" button. This is an optional feature, designated by the Model Number Suffix "-ASC." The time delay period ranges from a minimum of about 30 seconds to a maximum of about 3 minutes.

* If DPDT relay contacts are required for a particular application, this can be accomplished if a spare channel is supplied on the alarm console. After wiring the field sensor to Input Terminals 1 and 2, simply install 2 short jumper wires at the sensor input terminal block: one (1) between Terminals 1 and 3, the other between Terminals 2 and 4. This will cause both output relays to be controlled by just one field sensor.

Operation and Installation Manual

-External Horn Reset - If desired to have the LC1000 also control and silence an external, remotely mounted horn, this can be done by wiring the output relay contacts for the selected channel ("N.O." for normally open, "N.C." for normally closed) in series with your external horn and its power source. In addition, a PC board jumper must be removed (see PC board layout): If channel one will control the external horn, remove Jumper "P-R," -if channel 2, remove Jumper "S-T." If more than one channel will be used to control the same horn, then each channel's relay contact "common" terminals should be "jumped" and the associated "NO" or "NC" terminals should be jumped. For multiple channel horn control to work properly, all relay contacts must be of the same form, either N.O. or N.C. Note that implementing this feature eliminates using the associated relay contacts for other control devices. Use an external horn that is rated 2 amps at 120 VAC or less for this feature.

-Horn Silence From a Remote Location - If desired to silence the LC1000 horn from a separate location, this can be done by running a pair of wires from your own normally open, momentary pushbutton switch in parallel with the LC1000 "reset" switch normally open contact positions. Separate power is not required.

TEST MODES

The On/Off switching control operation of the LC1000 makes it simple to test and trouble-shoot the system. Pressing the "Test" button performs a functional test of the horn, all indicator lights and all relay contacts. Before pressing "Test", make sure all externally controlled devices are on standby or are accordingly addressed.

To check the operation of the LC1000 from a field wiring location, e.g., at the field sensor location, simply place a jumper wire between the field wire pair for normally open sensors, or open the field wire pair for normally closed sensors. This action will set the LC1000 into alarm mode.

MANUAL TEST FLOAT SWITCH

A special adaptation of the LS600 Float Level Switch provides for a 100% system performance test. Designated by the Model Number suffixes "-NCL" or "-NOL," this float switch is equipped with a mechanical lifting lever for manually raising the float through its switching position while still installed in the tank. See Sensor Installation Drawing, Figure 4, for full installation and operating instructions.

Operation and Installation Manual

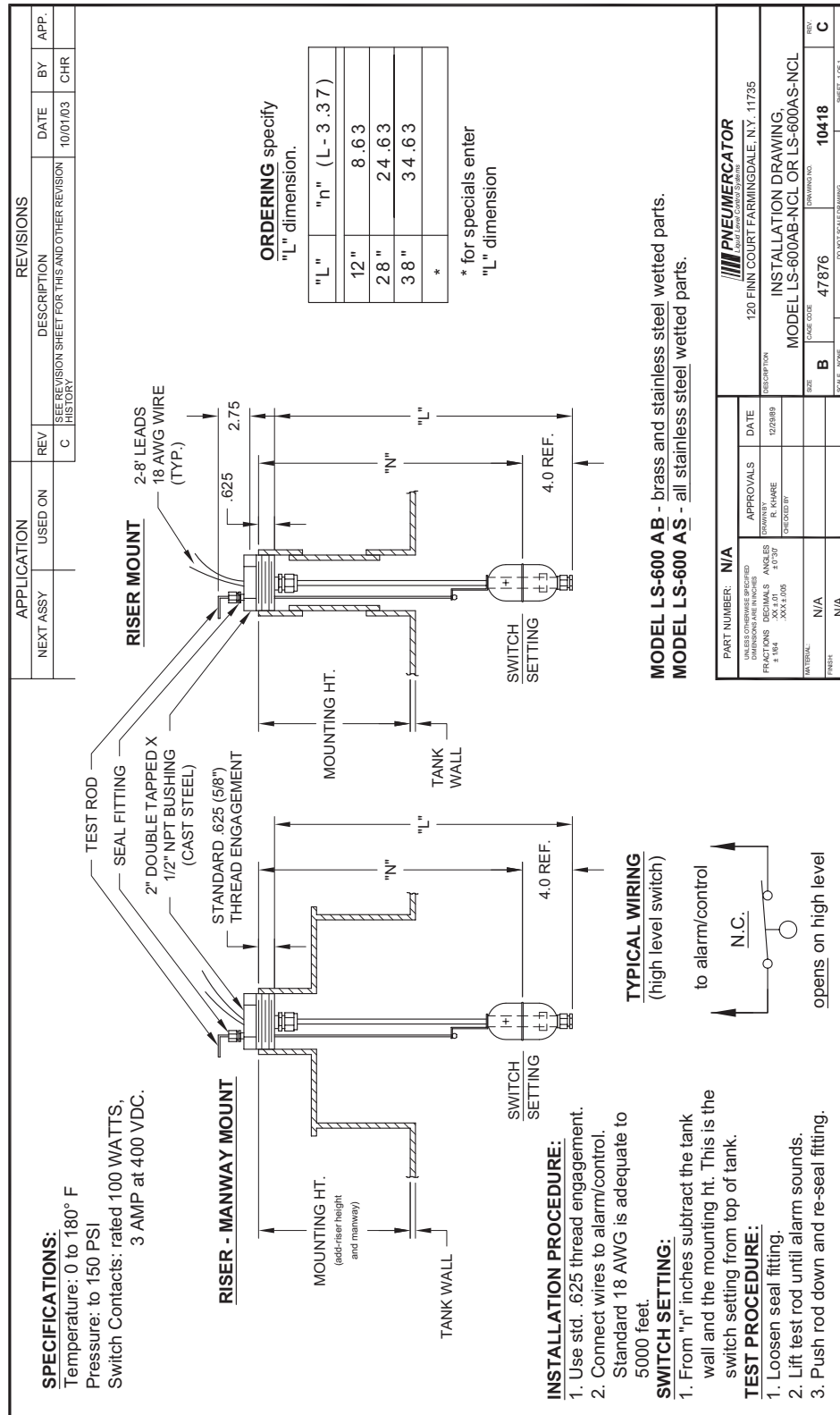

Figure 4 - LS600A-NCL Installation Drawing

WARRANTY

We warrant that our tank gauges, if installed according to instructions will be free from defects in material and workmanship for a period of one (1) year following the date of original shipment by us.

Our liability under this warranty shall be limited to, at our option, (I) repair of the defective tank gauge, (II) replacement of the original tank gauge with new, or (III) refund of the original purchase price; and, we shall not be liable for any labor, other installation costs, indirect or consequential damages, or other damages in connection with such gauge.

This constitutes our obligation and none other stated for any purpose except the above shall apply.



Pneumercator Co.
120 Finn Court, Farmingdale NY
TEL: (631) 293-8450 • FAX: (631) 293-8533
SUPPORT: (800) 209-7858
www.pneumercator.com

Distributed by:

--