

Telephone 800-500-9311  
Telephone 864-573-9200  
Fax 864-573-9299

# OEC FLUID HANDLING INC.

SUBSIDIARY OF OILMEN'S EQUIPMENT CORP.  
[www.oecfh.com](http://www.oecfh.com)

140 Cedar Springs Rd.  
P. O. Box 2807  
Spartanburg, SC 29304

■ Stocked Items 11/06/03

## PD Pumps

- ARO Ingersoll-Rand
- Blackmer Vane  
Blackmer/Abaque Peristaltic  
Blackmer "C" Eccentric Disc
- Alfa Laval-TriClover Lobe
- APV Lobe
- Tuthill Gear  
Tuthill Lobe  
MonoFlo Progressive Cavity

## Centrifugal Pumps

- Alfa Laval-TriClover Sanitary
- APV Crepaco
- Deming End Suction  
Deming Vertical Turbine
- Griswold ANSI Pumps
- MP Pump

## Specialty Pumps

Flux Drum

## Petroleum-Fuel Pumps

- Gorman-Rupp
- Dresser Wayne Corp
- Red Jacket  
Graco  
William Wilson Gasboy

## Hand Pumps

- Blackmer
- Tokhiem
- Tuthill Fill-Rite

## Storage Tanks

Stainless Steel ASME  
UL & ASME Carbon Steel  
Fiberglass Tanks  
Chem-Tainer Poly Tanks  
Assmann Poly Tanks  
Snyder Poly Tanks

## Tank Fittings & Vents

- OPW Engineered Systems  
EMCO Wheaton  
Morrison Bros  
Protectoseal

## Mechanical Seals

Utex



## Meters & Instrumentation

- Micro Motion Coriolis
- Neptune Actaris PD
- Tuthill FPP PD
- Liquid Controls PD  
Halliburton Turbine  
Rosemount  
Pressure Transmitters  
Flow Transmitters  
Temperature Transmitters  
Level Transmitters

## Sanitary Products

- Alfa Laval-TriClover Pumps
- Alfa Laval-TriClover Fittings  
Alfa Laval-TriClover Valves  
APV Pumps  
APV Valves  
APV Homogenizers  
B & A Flexible Sanitary Hose

## Liquid Level Gauges

- Protectoseal  
Pneumercator  
Moorman Bros  
Milltronics/Siemens  
Rosemount Level Transmitters

## Hose & Reels

- Goodyear Hose
- Hannay Reels  
Lawrence Composite Hose

## Filters

Filtration Group Bag Filters

## Mixers

Brawn Portable & Sanitary  
Proquip Top Entry Agitators

## Liquid Loaders & Platforms

OPW Engineered Systems  
Green Manufacturing

## Rotary Unions

Deublin

## Custom Liquid Systems

For liquid transfer, batching &  
process metering

**Performance Guaranteed**

CHARLOTTE, NC ■ SPARTANBURG, SC ■ GREENSBORO, NC

## LS600 Liquid Level Float Switch Installation Instructions

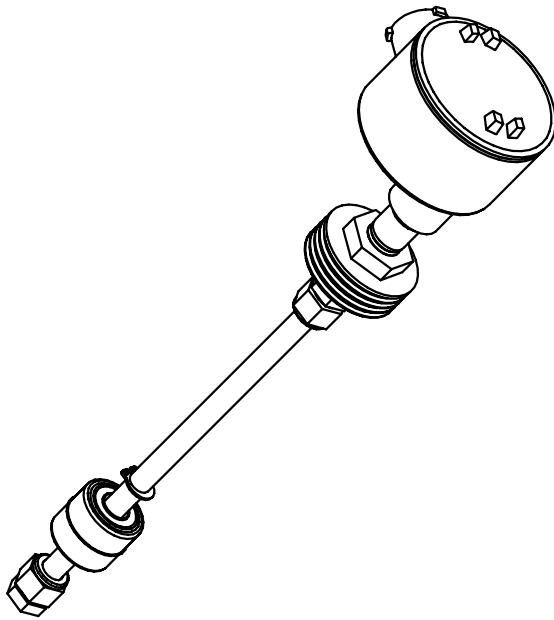

**Installation For Model Series: LS600, LS600A, LS600A-NCL  
and LS600-OW**

© COPYRIGHT 2004 PNEUMERCATOR CO., INC.  
120 FINN COURT, FARMINGDALE, NY 11735

TEL: (631) 293-8450 FAX: (631) 293-8533 [www.pneumercator.com](http://www.pneumercator.com)  
PNEUMERCATOR TECHNICAL SUPPORT  
1 (800) 209-7858

**PRODUCT DESCRIPTION:** The LS600 liquid level float switch consists of 4 model series as shown in the table below. All model series are supplied with minimum (1), maximum (4) floats for liquid level sensing. Models ending with "NCL" are supplied with manual lift rod on top float. "OW" units are supplied with interface float(s) designed to sense levels between two immiscible liquids, typically used in an oil/water separator tank. Units can be designed to automatically detect field wiring faults when used with Pneumercator's TMS series controller FAULT-DETECT supervised wiring technology.

MODEL SERIES	FIGURE	MOUNTING ACCESSORIES	* STANDARD SET POINT "S"				STANDARD SENSING LENGTH "SL"				STANDARD SHAFT LENGTH "L"			
			A	B	C	D	A	B	C	D	A	B	C	D
LS600	1	HOUSING, NIPPLE & BUSHING SUPPLIED	6"	8"	12"	16"	7 1/4"	9 1/4"	13 1/4"	17 1/4"	10"	12"	16"	20"
LS600-OW														
LS600A		HOUSING, NIPPLE & BUSHING NOT SUPPLIED	8"				9 1/4"				12"			
LS600A-NCL	2	BUSHING SUPPLIED	8"				9 1/4"			13"				

\* NORMALLY STOCK SIZES FOR STANDARD TANK MOUNT SHOWN IN TABLE ABOVE. CUSTOM SIZES FOR RISER OR STANDARD TANK MOUNT MAYBE SPECIFIED BY CUSTOMER. NOTE THAT "S1" IS CLOSEST TO THE BOTTOM FOR MULTIPLE POINT SWITCHES.

**FIGURE 1**

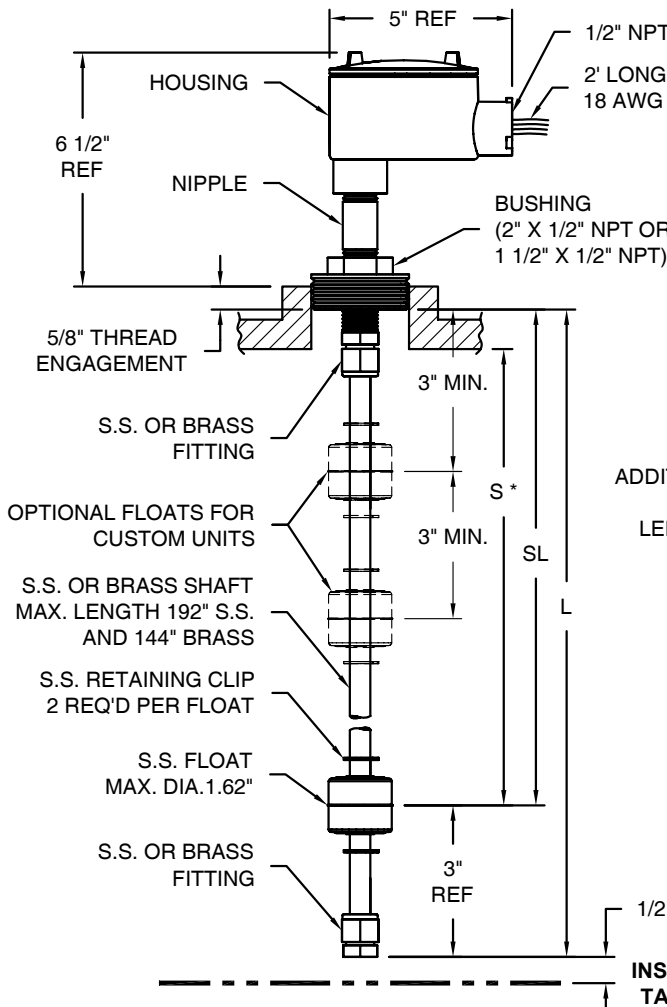

**FIGURE 2**

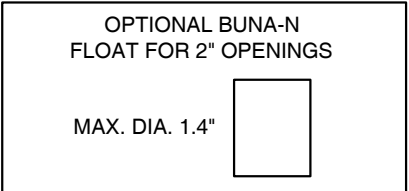
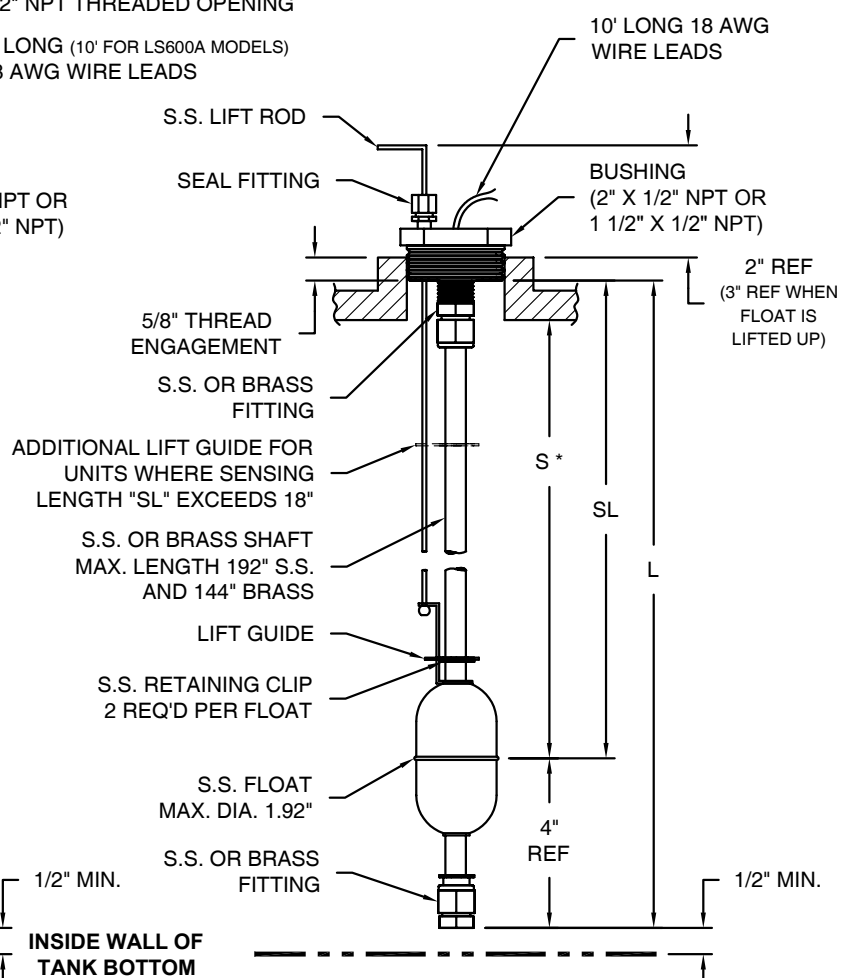

## SPECIFICATIONS

**Temperature:** -20°F to 180°F standard  
-40°F to 260°F with "X" suffix option.

**Pressure:** Full vacuum to 150 PSIG.

**Repeatability:** 1/8" typical per set point.

### **Approvals:**

UL913 Entity

Approved intrinsically safe for Class I, Groups C & D hazardous locations when installed in accordance with wiring drawing 50187 Ref. E139464.

UL508 General Purpose Use

Rated 0.5A @ 120VAC, inductive.

Rated 0.25A @ 240VAC, inductive.

FM

Approved intrinsically safe with entity for Class I, II, III, Division I, Groups A, B, C, D, E, F, & G under file No. 1Q3A4.AX when used in combination with a Pneumercator LC1000 series alarm console.

**APPLICATIONS:** LS600 float switches are typically used in above and below ground liquid storage tanks for point level alarm and pump control applications. The float switches are used with systems such as Pneumercator LC100x Alarm Panel, PC100x Pump Controller, TMS series Tank Management System or any monitor that accepts dry contact switches to actuate audible/visual alarm indicators or relay controls. The "NCL" manual lift model has the advantage of providing a means for lifting the uppermost float to verify operation without removing the switch assembly from the tank. The "OW" models are generally used to detect HIGH and/or CRITICAL HIGH oil levels in oil/water separator tanks.

## INSTALLATION:

**WARNINGS:** Non-compliance with the following warnings will void the warranty and may result in personal injury and/or property damage.

- Installation **MUST** be done by qualified personnel, familiar with local wiring codes and if applicable, explosion hazard electrical practices.
- The UL508 "General Purpose Use" electrical ratings listed above apply **ONLY** to ordinary location, non-hazardous installations.
- If housing must be removed for installation, hold nipple in place while unscrewing the housing. **DO NOT** rotate bushing or nipple relative to float shaft as this will damage internal wiring.
- **DO NOT** move float retaining clips. Improper positioning of retaining clips may disable switch actuation.
- **NEVER** modify factory-installed components.

## TYPICAL MOUNTING INSTALLATIONS

1. Confirm the standard set point "S" and shaft length "L" as shown in the table on page 2. If installing a custom unit, confirm your measurements with the customer tank information given to Pneumercator.
2. Refer to the applicable mounting installation drawing from page 4 or 5.

# INSTALLATION CONTINUED:

## LS600 MODEL SERIES

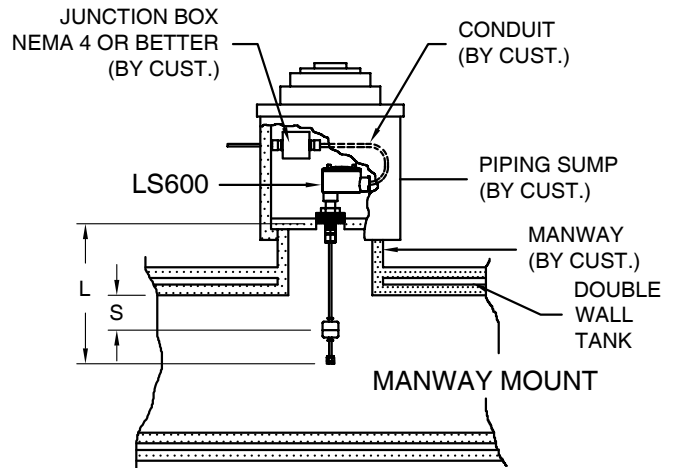
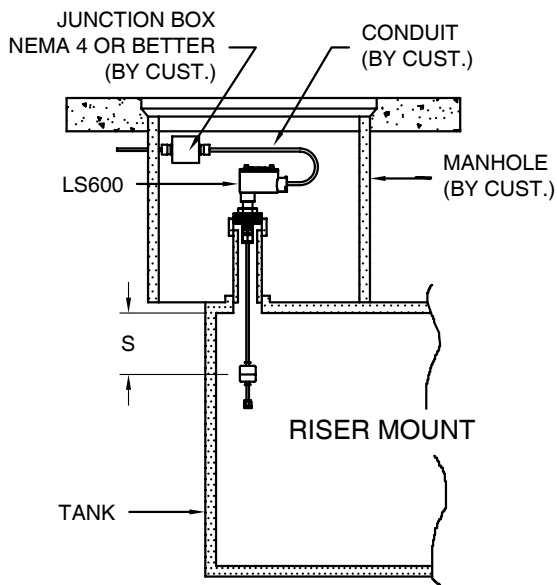
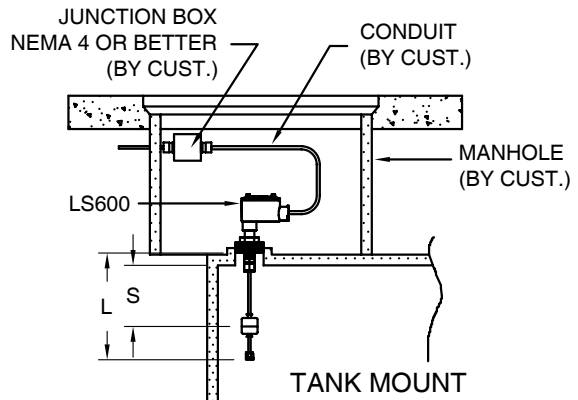
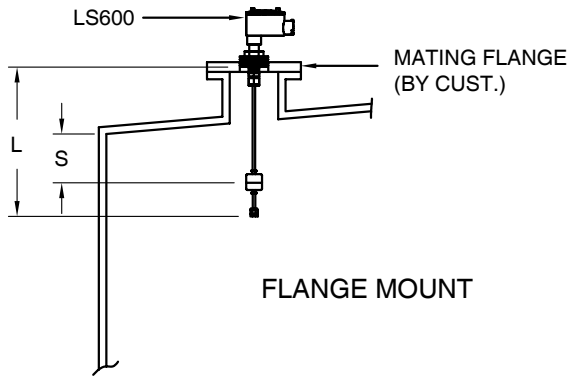

## LS600 OW MODEL SERIES

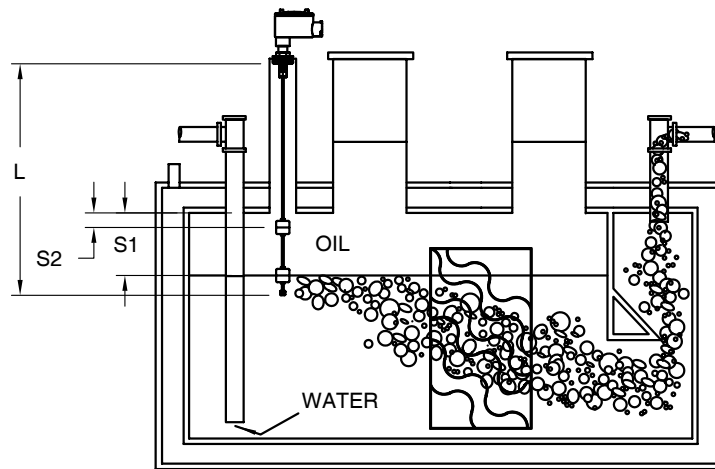

OIL/WATER SEPARATOR TANK TYPICAL DOUBLE WALL

# INSTALLATION CONTINUED:

## LS600A MODEL SERIES

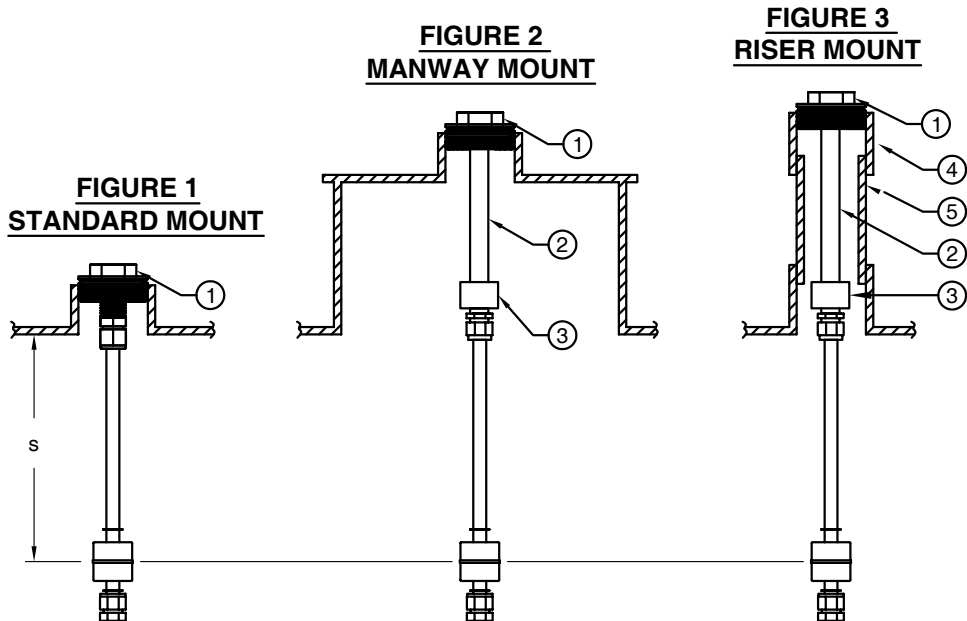

CUSTOMER SUPPLIED ITEMS	
ITEM	DESCRIPTION
1	2" DOUBLE TAPPED 1/2" NPT BUSHING
2	1/2" NPT CONDUIT PIPE
3	1/2" NPT COUPLING
4	2" NPT COUPLING
5	2" NPT STANDPIPE

### PROCEDURE:

1. STANDARD 8" HIGH LEVEL (FIGURE 1)
  - a) FACTORY SET AT 8", SCREW INTO BUSHING (ITEM 1).
2. MANWAY MOUNTED (FIGURE 2)
  - a) ADD PIPE (ITEM 2, LENGTH AS NECESSARY) AND COUPLING (ITEM 3) TO REACH BUSHING (ITEM 1) AT TOP OF MANWAY.
  - b) TO CHANGE SWITCH SETTING SHORTEN PIPE (ITEM 2).
3. RISER MOUNT (FIGURE 3)
  - a) ADD PIPE (ITEM 2, LENGTH AS NECESSARY) AND COUPLING (ITEM 3) TO REACH BUSHING (ITEM 1) AT TOP OF STANDPIPE COUPLING (ITEM 4).
  - b) TO CHANGE SWITCH SETTING, SHORTEN PIPE (ITEM 2).

## LS600A NCL MODEL SERIES

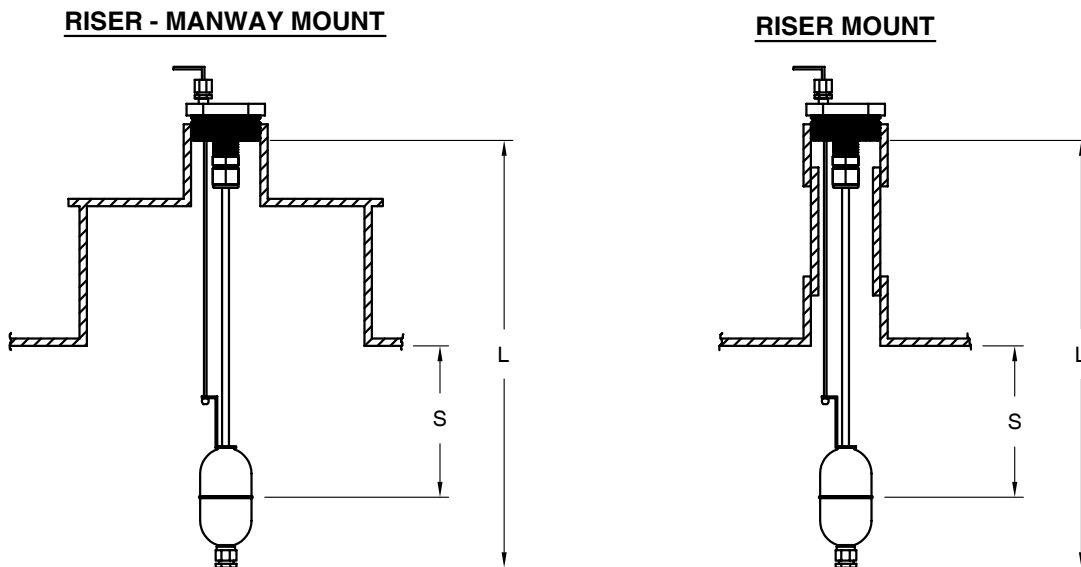

**WIRING:** If installing in a hazardous location, wire and install in accordance with Article 504 of National Electric Code ANSI/NFPA 70. Intrinsically Safe Wiring CANNOT be run in conduit or open raceways together with non-intrinsically safe wiring.

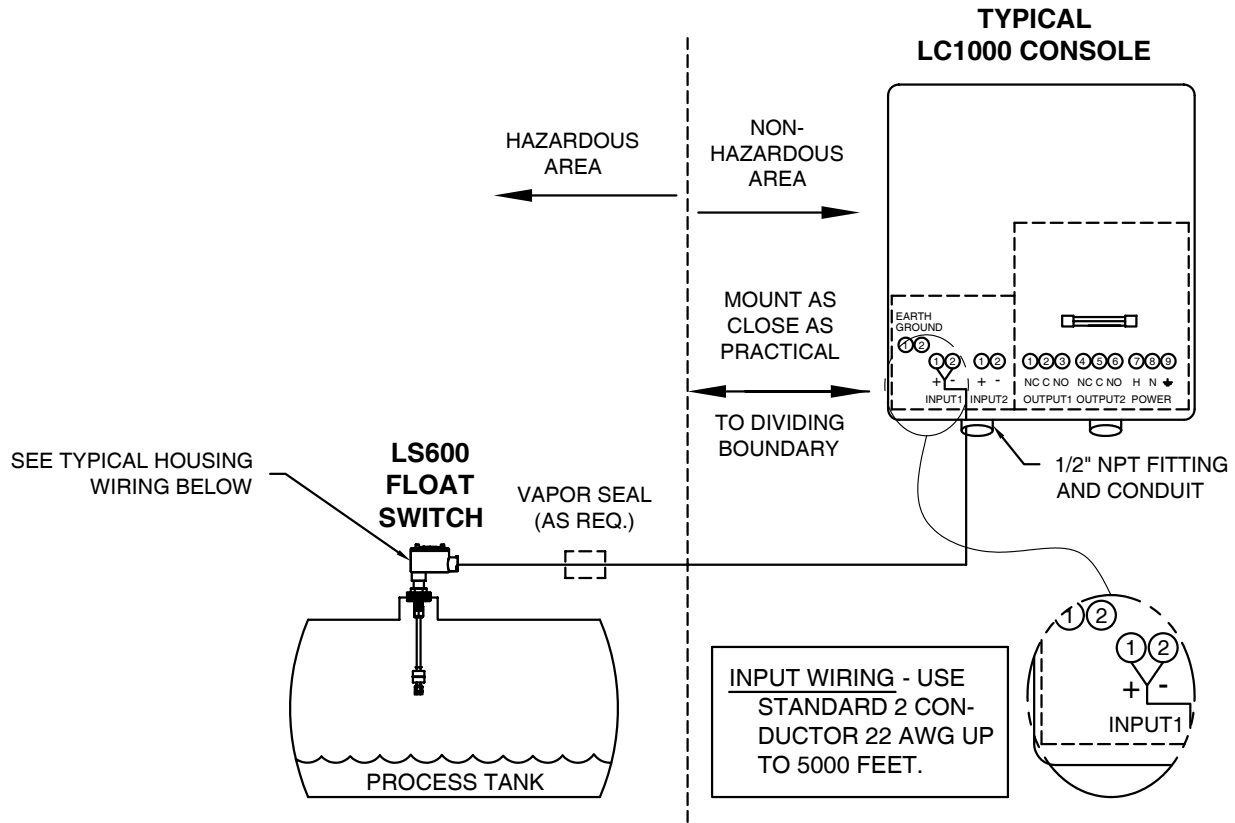

**TYPICAL WIRING IN HOUSING**

REQUIRED FITTINGS PROVIDED BY INSTALLER

WIRE LEADS

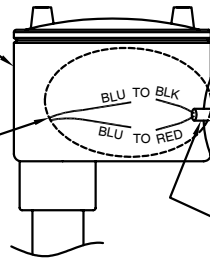

CONDUIT AND VAPOR SEAL FITTING PROVIDED BY INSTALLER

\* BELDEN 8442 COLORS SHOWN

TO CONSOLE

FIELD CABLE \*

WIRING CONNECTOR P/N 316033-2  
(connector not included with LS600, follow included bulletin 179 instructions)

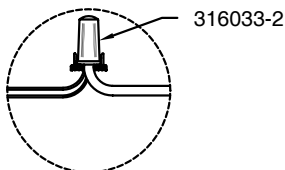

— OR —

SPLICE SEAL KIT P/N 10518-2  
(kit not included with LS600)

**Note:** Wire splices and cable sheath ends must be sealed with epoxy from kit or suitable waterproofing sealant.

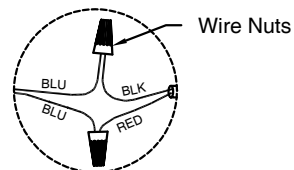

**COLOR CODES:** All switches are set in a dry tank.

LS600 COLOR CODES		
TYPICAL SWITCH I.D.	N.O. WIRE LEADS	N.C. WIRE LEADS
OVERFILL	GRY/WHITE	GRAY
H. HIGH	VIO/WHITE	VIOLET
HIGH	BLU/WHITE	BLUE
PUMP STOP	RED/WHITE	RED
PUMP START	ORN/WHITE	ORANGE
LOW	YEL/WHITE	YELLOW
L. LOW	BRN/WHITE	BROWN

**SCHEMATIC DRY TANK \***

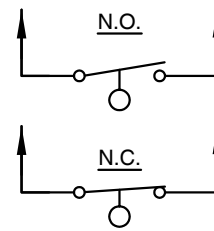

\* ALL SWITCHES ARE SET IN A DRY TANK

**MAINTENANCE PROCEDURES:** Pneumercator strongly recommends annual testing to ensure proper actuation of any float switch designated for overfill prevention. Additionally, it is recommended practice to annually test all point-level switches on multi-switch assemblies.

**"NCL" Models:**

1. Loosen seal fitting on manual lift rod.
2. Lift test rod until alarm or control point activates. If activation cannot be confirmed, troubleshoot as per step 7 maintenance procedures for all models below.
3. Push rod down and reseal fitting.

**All Other Models:**

1. Turn off power to the monitoring console or panel.
2. Disconnect switch wiring leads from field cable.
3. Unscrew field wiring conduit from housing if supplied.
4. Unscrew switch assembly bushing from tank mount.
5. Lift unit from tank and clear any debris that may have collected.
6. Temporarily reconnect switch wiring leads to field cable. DO NOT seal connections.
7. Re-apply power and manually actuate each float to confirm alarm or control point activation. If activation cannot be confirmed, troubleshoot in the following order:
  - a) Disconnect wiring for the suspect switch and confirm "open" and "closed" state of switch with an ohmmeter or continuity tester. If failure, switch is defective.
  - b) Check field wiring continuity from end to end in the "open" and "closed" state. If failure, replace field wiring.
  - c) Disconnect field wiring at console and simulate "open" and "closed" state of switch with a jumper wire connected to appropriate terminals of console. If failure, console is defective.
8. Disconnect temporary connections, reinstall unit, and restore field wiring connections.
9. Apply new seal kit to connections.