

Telephone 800-500-9311
Telephone 864-573-9200
Fax 864-573-9299

OEC FLUID HANDLING INC.

SUBSIDIARY OF OILMEN'S EQUIPMENT CORP.
www.oecfh.com

140 Cedar Springs Rd.
P. O. Box 2807
Spartanburg, SC 29304

■ Stocked Items 11/06/03

PD Pumps

- ARO Ingersoll-Rand
- Blackmer Vane
Blackmer/Abaque Peristaltic
Blackmer "C" Eccentric Disc
- Alfa Laval-TriClover Lobe
- APV Lobe
- Tuthill Gear
Tuthill Lobe
MonoFlo Progressive Cavity

Centrifugal Pumps

- Alfa Laval-TriClover Sanitary
- APV Crepaco
- Deming End Suction
Deming Vertical Turbine
- Griswold ANSI Pumps
- MP Pump

Specialty Pumps

Flux Drum

Petroleum-Fuel Pumps

- Gorman-Rupp
- Dresser Wayne Corp
- Red Jacket
Graco
William Wilson Gasboy

Hand Pumps

- Blackmer
- Tokhiem
- Tuthill Fill-Rite

Storage Tanks

Stainless Steel ASME
UL & ASME Carbon Steel
Fiberglass Tanks
Chem-Tainer Poly Tanks
Assmann Poly Tanks
Snyder Poly Tanks

Tank Fittings & Vents

- OPW Engineered Systems
EMCO Wheaton
Morrison Bros
Protectoseal

Mechanical Seals

Utex

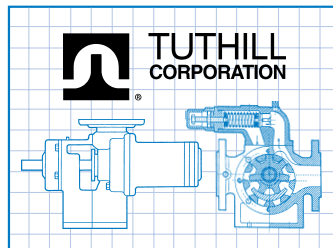
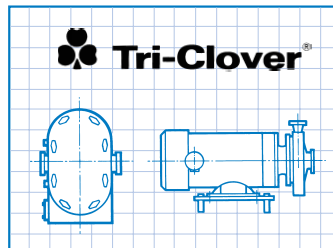
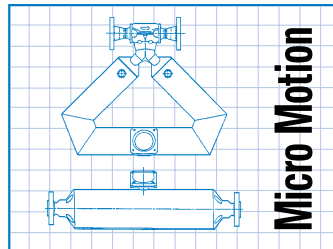
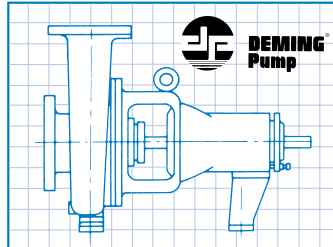
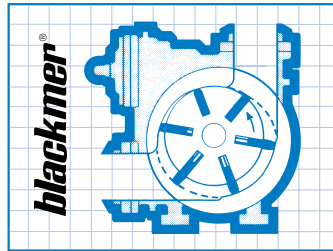
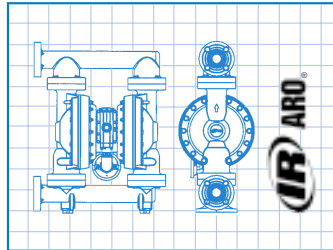

Meters & Instrumentation

- Micro Motion Coriolis
- Neptune Actaris PD
- Tuthill FPP PD
- Liquid Controls PD
Halliburton Turbine
Rosemount
Pressure Transmitters
Flow Transmitters
Temperature Transmitters
Level Transmitters

Sanitary Products

- Alfa Laval-TriClover Pumps
- Alfa Laval-TriClover Fittings
Alfa Laval-TriClover Valves
APV Pumps
APV Valves
APV Homogenizers
B & A Flexible Sanitary Hose

Liquid Level Gauges

- Protectoseal
Pneumercator
Moorman Bros
Milltronics/Siemens
Rosemount Level Transmitters

Hose & Reels

- Goodyear Hose
- Hannay Reels
Lawrence Composite Hose

Filters

Filtration Group Bag Filters

Mixers

Brawn Portable & Sanitary
Proquip Top Entry Agitators

Liquid Loaders & Platforms

OPW Engineered Systems
Green Manufacturing

Rotary Unions

Deublin

Custom Liquid Systems

For liquid transfer, batching &
process metering

Performance Guaranteed

CHARLOTTE, NC ■ SPARTANBURG, SC ■ GREENSBORO, NC

INSTALLATION AND SERVICE INSTRUCTIONS HD SERIES PUMPS INDUSTRIAL DUTY MODELS

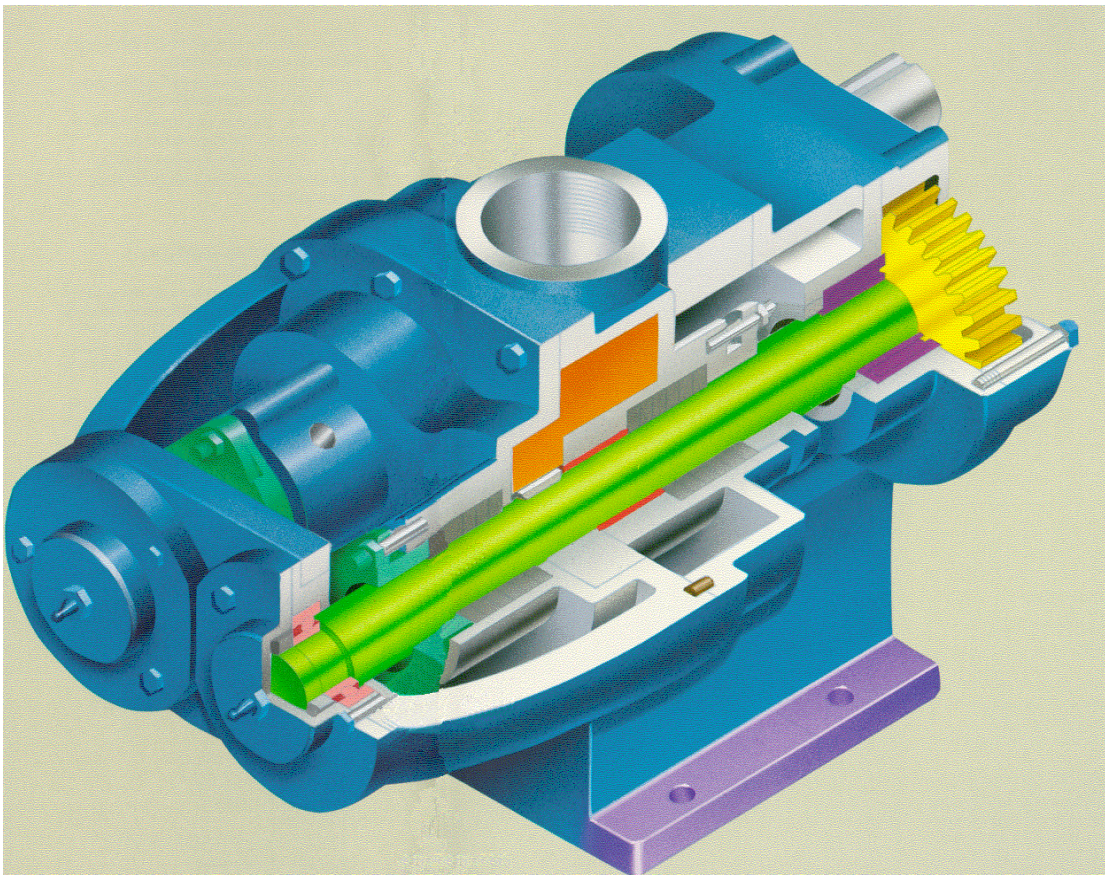

TUTHILL
Pump Group

12500 South Pulaski Road
Alsip, Illinois USA 60803
Tel 708 389-2500 Fax 708 388-0869
email: tuthillpump@tuthill.com
www.tuthill.com

WARNING



WARNING

Read Manual before operating or working on a Tuthill HD pump.

Table Of Contents

Page 3:	Introduction
Page 4:	General Description / Pumping Principle / HD Models
Page 5:	HD Model Numbering System
Page 6:	Temperature Limits
Page 7:	Installation
Page 8:	Packing Adjustments
Page 9:	Lubrication Requirements / Recommended Lubricants
Page 10:	Inspection and Repair
Page 11:	Parts Diagram
Page 12:	General Parts List (30A, 2A, 3A, 70A, 120A & 330 Pumps)
Page 13:	Minor Disassembly Instructions (30A, 2A, 3A, 70A, 120A & 330 Pumps)
Page 14:	Minor Assembly Instructions (30A, 2A, 3A, 70A, 120A & 330 Pumps)
Page 15:	Major Disassembly Instructions (30A, 2A, 3A, 70A, 120A & 330 Pumps)
Page 16:	Major Assembly Instructions (30A, 2A, 3A, 70A, 120A & 330 Pumps)
Page 17:	Pump Clearances (30A, 2A, 3A, 70A, 120A & 330 Pumps)
Page 18:	Parts Diagram (Model 600 Pump)
Page 19:	General Parts List (Model 600 Pump)
Page 20-21:	Minor Disassembly Instructions (Model 600 Pump)
Page 22:	Minor Assembly Instructions (Model 600 Pump)
Page 23-24:	Major Disassembly Instructions / Major Assembly Instructions (Model 600 Pump)
Page 25:	Pump Clearances (Model 600 Pump)
Page 25-27:	Packing Section
Page 28:	Torque Specifications For Shaft Locknuts & Faceplate Bolts
Page 29:	Serial Number Location
Page 30:	Common Pump Problems
Page 31:	Troubleshooting
Page 32:	Material Returns / Warranty / Contact Information

Introduction

The HD Series pumps have been certified to the requirements of the ATEX Directive 94/9/EC for use in Category II, Group 2 G applications. Read this manual before operating or working on the HD Series pumps. If additional information is required to facilitate operation or maintenance, contact the authorized Tuthill distributor shown at the back of this service manual.

HD Series pumps have been designed and manufactured to provide years of service under normal operating conditions.

Illustrations used in this manual are for reference purposes only. Consult the factory or an authorized Tuthill distributor for proper part identification.

When ordering replacement parts, provide as much detail as possible to ensure correct parts are provided. Details should include the full model number (typically 12-13 digits but can be 18 digits), serial number, name of part, part number (if known), and part material.

Service Manual # 71 for the HD Series pumps is available at www.tuthillpump.com

The materials furnished for each pump are selected to suit individual applications.

WARNING



WARNING

Failure to follow these instructions could result in serious bodily injury or death.

Do not attempt to work on any Tuthill pump installation before completing the steps below.

Disconnect the drive so that it cannot be started while work is being performed.

Review the Material Safety Data Sheet (MSDS) applicable to the liquid being pumped to determine its characteristics and the precautions necessary to ensure safe handling.

Vent all pressure within the pump through the suction or discharge lines.

All Tuthill pumps contain residual hydraulic oil from the factory production test.

Determine if this is compatible with the fluid you are pumping. If the fluid is incompatible, then the pump must be fully flushed prior to use.

If the pump is to be operated at elevated temperatures, the pump should be brought up to operating temperatures gradually. Rapid or sudden introduction of liquids at elevated temperatures into the cold liquid chamber of the pump could cause damage to pump externals, seals or other internal parts.

Pumps can run dry provided provisions are made for the mechanical seal if one is used. Failure to comply with this could cause severe damage to the mechanical seal parts.

Pump needs to be earthed separately to avoid a buildup of electro-static charge.

General Description

The design of the Tuthill Industrial Series incorporates externally timed impellers that are supported in the fluid chamber by double row, ball bearings located out of the product stream. This design enables the industrial Series to handle highly viscous abrasive slurries, corrosive acids or suspended solids without degradation, aeration or contamination of the product.

PUMPING PRINCIPLE:

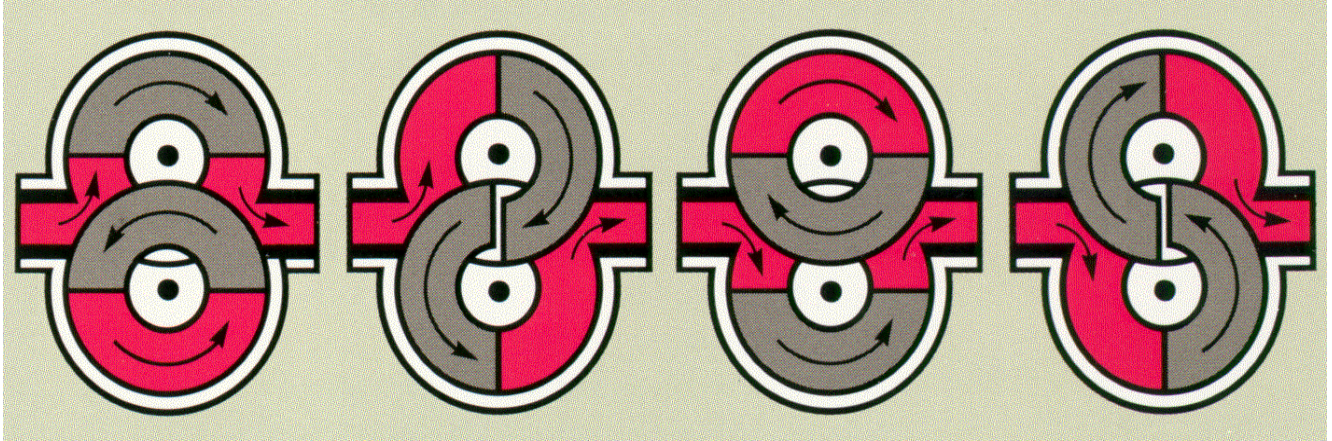

Here's how it works:

Rotating impellers develop a vacuum at inlet, drawing material into the cavity...positive action of the impellers displaces material, forcing discharge at pump outlet. Ports are always open; sealing action between impellers and housing prevents fluid flow return.

HD Models

Material of Construction	Size	Max. Speed	Max. Capacity		Max. Pressure		Weight		Port Size (Internal NPT)
			USGPM	LPM	PSI	BAR	LB	KG	
Ductile Iron	30A	450	24.7	93	150	10.3	100	45	1-1/2" Top 1-1/2" Front
	2A	450	67.5	256	150	10.3	250	113	2" Top 2" Front
	3A	450	135	511	150	10.3	270	122	3" Top 3" Front
	70A	450	67.5	256	450	27.5	280	127	3" Top 2" Front
	120A	450	135	511	450	27.5	300	136	4" Top 3" Front
	330	450	337	1276	450	27.5	550	249	5" Top 4" Front
	600	450	666	2523	450	27.5	900	408	6" Right 6" Left
Stainless Steel	30A	450	24.7	93	150	10.3	100	45	Same As Above
	2A	450	67.5	256	150	10.3	250	113	Same As Above
	3A	450	135	511	150	10.3	270	122	Same As Above
	70A	450	67.5	256	450	27.5	280	127	Same As Above
	120A	450	135	511	450	27.5	300	136	Same As Above
	330	450	337	1276	450	27.5	550	249	Same As Above
	600	450	666	2523	450	27.5	900	408	Same As Above

HD PROCESS PUMP NUMBERING SYSTEM

1	2	3	4	5	6	7	8	9	10	11	12	13
---	---	---	---	---	---	---	---	---	----	----	----	----

<i>DIGITS 1 & 2</i>	O1-INDUSTRIAL DUTY (ID)	O2-STANDARD DUTY (SD) Ductile Iron Only	O4-STANDARD DUTY (SD) Stainless Steel Only
<i>DIGITS 3 & 4</i>	05 – Model 30 14 – Model 2A 16 – Model 70A 29 – Model 3A 31 – Model 120A 75 – Model 330 91 – Model 600	01 – Model 5A 02 – Model 10 03 – Model 16 05 – Model 25A 14 – Model 65 26 – Model 125A	
<i>DIGITS 5 & 6</i>	04 – 316 Stainless Steel (O1 & O4 Models) 09 – Ductile Iron (O1 & O2 Models)		
<i>DIGIT 7</i>	0 – Internal NPT (Std. on ID models) 1 – External NPT (Standard on SD models)		
<i>DIGIT 8</i>	0 – No Relief Valve 1 – Relief Valve (Available on all SD models & ID models 30, 2A, 3A, 70A, 120A)		
<i>DIGITS 9 & 10</i>	01 – Hot Clearance 02 – Special Shaft Material 05 – Special Packing 06 – Special Packing Configuration 08 – Mechanical Seals 09 – Special Bushings 10 – Special Clearances 13 – Steam Jacket/Tracing 19 – Special Ports (Flanged, etc.) 21 – Tutriding 26 – Interference Fit Gears 27 – Special U-Cup/Lip Seals 28 - Miscellaneous		
<i>DIGITS 11 & 12</i>	01, 02, Etc. (Serialized at the factory)		
<i>DIGIT 13 (If Required)</i>	D – Double Lobe (Available on ID models only) T – Teflon housing and faceplate bushings (SD Models)		

TEMPERATURE LIMITS OF HD PROCESS PUMP MATERIALS

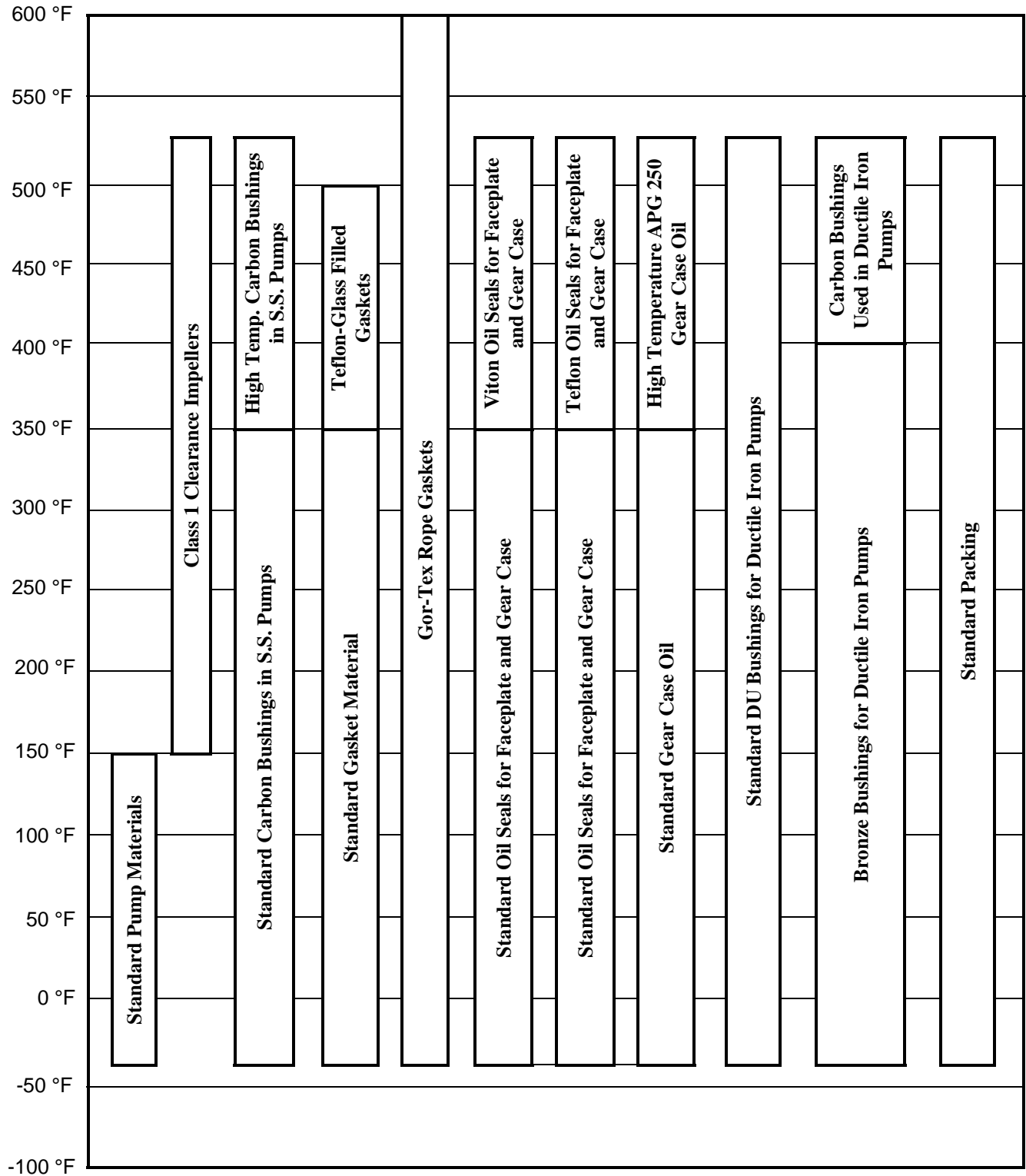

Note:

- Viton and Teflon oil seals can be used in place of standard oil seals upon request.
- Teflon and Gor-Tex gaskets can be used in place of standard seals upon request.

WARNING



WARNING

Failure to follow these instructions could result in serious bodily injury or death.

Do not attempt to work on any Tuthill pump installation before completing the steps below.

Disconnect the drive so that it cannot be started while work is being performed.

Review the Material Safety Data Sheet (MSDS) applicable to the liquid being pumped to determine its characteristics and the precautions necessary to ensure safe handling.

Vent all pressure within the pump through the suction or discharge lines.

All Tuthill pumps contain residual hydraulic oil from the factory production test.

Determine if this is compatible with the fluid you are pumping. If the fluid is incompatible, then the pump must be fully flushed prior to use.

If the pump is to be operated at elevated temperatures, the pump should be brought up to operating temperatures gradually. Rapid or sudden introduction of liquids at elevated temperatures into the cold liquid chamber of the pump could cause damage to pump externals, seals or other internal parts.

Pumps can run dry provided provisions are made for the mechanical seal if one is used. Failure to comply with this could cause severe damage to the mechanical seal parts.

Pump needs to be earthed separately to avoid a buildup of electro-static charge.

Installation

For optimum pump performance the suction line must be at least as large as the corresponding pump port. It should be as short as possible in order to avoid excessive pressure drops and must be airtight. Locate the pump as close to the source of supply as conditions permit, and if possible, below the level of the liquid in the reservoir. When necessary to locate the pump in a pit, provisions should be made to safeguard against flooding.

When handling high viscosity liquids, the speed of the pump must be reduced and the size of the inlet lines increased to prevent cavitation. Refer to the NPSHr data for the pump.

Pumps should be filled with liquid at installation.

The placement of a strainer on the suction side of the pump will restrict any solids or abrasives from entering the pump, which could cause internal damage.

Under no conditions should the pump be used to support external piping loads (weight or expansion). Piping and other equipment should be independently supported. Piping strain can result in misalignment, hot bearings, worn couplings, vibration, etc. It is important that the piping used be clean and free of chips and scales.

The discharge line must be designed with the maximum pressure rating of the pump in mind. Excessive pressure could cause damage to your motor and/or pump. If a pressure relief valve has not been supplied with the pump, some other means of pressure protection must be utilized. This could include in-line safety valves, pressure shutdown switches or other similar devices.

Pumps are positive displacement pumps and must be used in conjunction with a pressure relief mechanism.

Every pump installation should have a good foundation. Its structure should be sufficiently strong to hold the pump rigid and to absorb any strain or shock that may be encountered. The installation should be leveled, checked for proper piping alignment, and then fastened securely. The alignment should be rechecked after the pump's temperature has reached its operating temperature.

Direct drive through a traditional flexible coupling is recommended. However, do not expect the coupling to compensate for misalignment. Contact the coupling manufacturer to determine the maximum amount of misalignment that the coupling can be subjected to.

Never operate the pumps without all the guards in place.

Direction of Flow:

Tuthill Industrial Process Pumps may be operated in either direction. The direction of flow is dependent on the direction of rotation of the pump drive shaft. When facing the drive shaft of the pump, a clockwise rotation provides a top suction port and a bottom discharge port. This applies to Model 30A, 2A, 3A, 70A, 120A, 330 Pumps (Page 11).

Model 600 Pumps are equipped with a vertical shaft arrangement (Page 18). On these models a clockwise drive shaft rotation will provide a left hand suction port and a right hand discharge port. Flow would be from left to right when facing the drive shaft.

Packing Adjustment

WARNING



WARNING

Packing is designed to leak. Therefore, when pumping hazardous liquids, a mechanical seal is recommended to minimize any potential source of leakage that could result in a hazardous condition.

All packings must leak to perform properly. Their purpose is to control leakage—not to prevent it.

The slight leakage along the shaft provides proper lubrication to the packing. Pump packings have a lubricant, which acts as a primary sealant for the start-up and break-in phases, during which this lubricant acts to reduce friction. Once the pump is on the line, external lubrication must be supplied to the packing to keep it running properly and to attain longer life. If external lubrication is not supplied, the lubrication in the packings will bleed out due to heat generation. Heat is a primary cause of packing failure.

Pumps with packing will require periodic adjustment.

To accomplish this, gently and evenly tighten the packing gland nuts, which will further compress the packing. Do not over-tighten. Packing is designed to keep leakage to a slight weep. Normally 2-3 drops per minute is acceptable.

If excessive leakage persists after complete adjustment, consider re-packing the stuffing box or using another packing type.

Lubrication Requirements

Faceplate Bearings:

The faceplate bearings are greased. Grease should be added to faceplate bearings when oil is changed. Add grease through fitting until new grease can be seen exiting under lip seal where shaft enters bearing. Bearings are designed to provide a minimum L10 life of 15,000 hours at maximum speed and pressures conditions.

Housing Bushing:

Housing bushings are fully lubricated by the pumped fluid and are maintenance free.

Gear Case Bearings:

Bearings are designed to provide a minimum L10 life of 15,000 hours at maximum speed and pressures conditions and are splashed lubricated.

Lubrication Instructions For Tuthill Process Pumps

The oil used in the gear case of the process pumps is "Lubriplate" APG9. Lubriplate is a trade name of Fiske Brothers Refining Company – Toledo, Ohio.

Oil specifications are as follow:

Viscosity at 100°F: 816 SSU Viscosity at 212°F: 86 SSU
API Gravity: 26.5 Flash Point: 39°F
Fire Point: 440°F Extreme Pressure Additives
Any 90-weight gear oil may be substituted if equivalent to above.

The grease used in the faceplate ball bearing of the Industrial Series pump is "Lubriplate" 1200-2.

Grease specifications are as follows:

Lithium Base N.L.G.I. #2
Work Penetration: 280 A.S.T.M. Dropping Point: 450°F
Minimum Oil Viscosity at 100°F: 950SSU
Water resistant with rust and corrosion inhibitors added.
Any #2 bearing grease may be substituted if equivalent to above.

The following charts on lubrication requirements are offered as a guide only. Common sense approach to preventative maintenance must be exercised for best pump service life. Ambient conditions (temperature, humidity, dust, etc.) can alter schedule:

<u>Model No.</u>	<u>Gearcase Capacity - CC</u>	<u>First Oil Change – Hrs.</u>	<u>Subsequent Change – Hrs.</u>	<u>Total Grease Capacity Per Pump - CC</u>
30A	500	500	3000	30
2A & 3A	1900	500	3000	35
70A & 120A	250	500	3000	165
330	1000	500	3000	140
600	1250	500	3000	100

Above standard lubricants are adequate for operating temperatures between –100°F and +350°F. If temperature exceeds 350°F, use the following:

Oil Specification: Lubriplate APG 250 or equal
Bearing Grease: 930-AA or equal

Inspection and Repair

Should it be necessary to remove the pump from service for periodic inspection of components and/or a major repair, the following steps should be taken. See following pages for exploded pump view and instructions.

WARNING



WARNING

Failure to follow these instructions could result in serious bodily injury or death.

Do not attempt to work on any Tuthill pump installation before completing the steps below.

Only authorized personnel who are familiar with the repair of mechanical products should perform the necessary repair work. You must familiarize yourself with the entire contents of this manual prior to performing any work.

Disconnect the drive so that it cannot be started while work is being performed.

Review the Material Safety Data Sheet (MSDS) applicable to the liquid being pumped to determine its characteristics and the precautions necessary to ensure safe handling.

Vent all pressure within the pump through the suction or discharge lines.

Ensure that the pump has cooled to a safe temperature prior to performing any work on the pump.

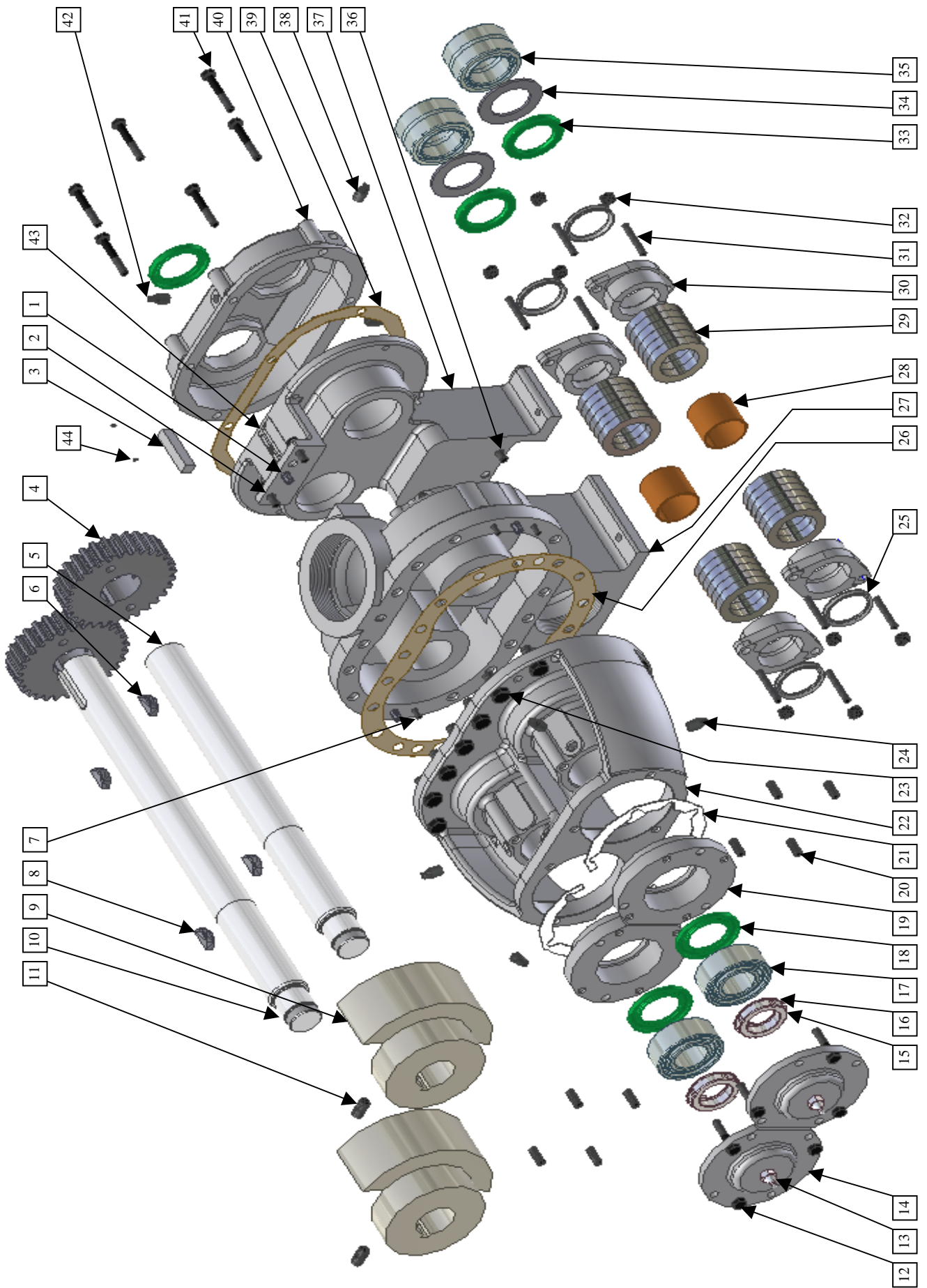

General Parts List For 30A, 2A, 3A, 70A, 120A, and 330 Pumps

Item #	Description	Qty
1	Dowel Pin	4
2	Cap Screw	2
3	Square Key	1
4	Timing Gears	2
5	Driven Shaft (CI)	1
	(SS)	
6	Gear Key	2
7	Cap Screw	*
8	Impeller Key (CI)	2
	(SS)	
9	Impellers (CI) S.L.	2
	(CI) D.L.	
	(SS) S.L.	
	(SS) D.L.	
10	Drive Shaft (CI)	1
	(SS)	
11	Set Screw (CI)	4
	(SS)	
12	Hex Head Bolt	6
13	Grease Fitting	2
14	Bearing Cover	2
15	Lock Nut	2
16	Lock Washer	2
17	Ball Bearing	2
18	Lip Seal	2
19	Bearing Carrier	2
20	Set Screw	*
21	Shim -----.002"	As Req.
	.005"	As Req.
	.015"	As Req.

Item #	Description	Qty
22	Faceplate (CI)	1
	(SS)	
23	Hex Head Bolt	*
24	Pipe Plug (CI)	8
	(SS)	
25	V-Ring	4
26	Housing Gasket	1
27	Impeller Housing (CI)	1
	(SS)	
28	Housing Bushings (CI) DU Bushing (SS) Carbon Bushing	2
29	Packing	4 sets
30	Packing Gland (CI)	4
	Split Glands for (SS)	8
31	Stud	8
32	Nut (CI)	8
	(SS)	
33	Lip Seal	3
34	Spacer	2
35	Roller Bearing	2
36	Cap Screw	2
37	Bearing Housing	1
38	Pipe Plug (CI)	2
	(SS)	
39	Gear Case Gasket	1
40	Gear Case Cover	1
41	Cap Screw	6
42	Vented Pipe Plug	1
43	Nametag	1
44	Drive Screw	2

Note:

- * Exact quantities will vary depending upon actual pump model.
- (CI) are Cast Iron pumps that will have corresponding steel and/or ductile iron components.
- (SS) are Stainless Steel pumps that will have corresponding stainless steel components.
- **Recommended spare parts are in bold text.**
- When ordering spare parts please specify pump model, serial number, part number & part name.

Disassembly & Reassembly Instructions for 30A, 2A, 3A, 70A, 120A, & 330 Pumps

Minor Disassembly For Fluid Chamber Inspection:

1. Remove all burrs on drive shaft with a file or emery paper. Also check for any deposit of paint. Special care should be taken around the keyway and beveled corner on the drive shaft. These two areas are normally where burrs occur. Burrs or paint will cause an obstruction in the bushing area.
2. Drain oil from gear case by removing lower drain plug (38). Remove six cap screws (41) on face of gear case cover (40).
3. Remove gear case cover by sliding over shafts.
4. **If the timing gears (4) are a slip fit on the shafts.** Check that the gears have the correct timing marks before removal. If necessary, mark them again. Remove the gears by loosening the setscrews. There are two in each gear. Then slide gears off drive end of shaft. If gear keys are sheared a gear puller may be required. NOTE: Mark gears so that in reassembly the gears may be remounted on the shafts from which they were removed. Remove two gear keys.(6)
5. **If interference fitted (IF) timing gears (4) are furnished.** Check that the gears have the correct timing marks before removal. If necessary, mark them again. IF gears do not have setscrews. First attempt to remove them can be made with a standard gear puller. If the gear puller was not successful in removing the gears, heat the gear OD with a torch and use a hydraulic jack to remove the gears. NOTE: Mark gears so that in reassembly the gears may be remounted on the shafts from which they were removed. Remove two gear keys.(6)

WARNING



WARNING

Wear heat-resistant gloves when handling hot components.

6. Remove packing gland nuts (32) and slide packing gland (30) out of the way. Then remove packing (29) from both seal chambers in the impeller housing. If pump is equipped with mechanical seals, refer to the seal instructions that were shipped with the pump.
7. Remove hex head bolts (23) on outboard side of faceplate. Make note on which side the drive shaft is located for reassembly. Remove entire faceplate assembly by sliding away from impeller housing. **CAUTION: Faceplate assembly will be heavy and not balanced. Use proper lifting methods.** This assembly includes the impellers and shafts installed in the faceplate. **CAUTION: DO NOT DISTURB** the bearing carrier (19) on the bearing bridge on the faceplate. These caps hold the adjustment of the clearance of the impellers in relation to the fluid chamber.

If further disassembly is required, refer to major disassembly instructions.

Fluid Chamber Check Points:

Procedure No. 1 - Check for twisted shaft

1. Place faceplate group upright in vise.
Caution: Use soft jaws to prevent damage to the gasket seal surfaces. Tighten jaws on sides of bearing bridge.
2. Install carbon steel gear keys on an angle. Angle is to hold gears from sliding down on shaft.
3. Slide proper timing gear on drive shaft, revolving shaft to align key with gear keyway, taking precautions that the timing marks are face out and aligned. There are two punch marks appearing on the gear on the drive shaft and one punch mark on the mating tooth on the driven shaft.

- Turn impellers to the position shown below. If the dimension X is the same as dimension Y, then there is no shaft damage. If there is a variation, then the shaft is twisted or the impeller keys may be sheared. Disassemble in accordance with major disassembly instructions. If the impeller keys are sheared, then install new keys and recheck for twisted shaft.

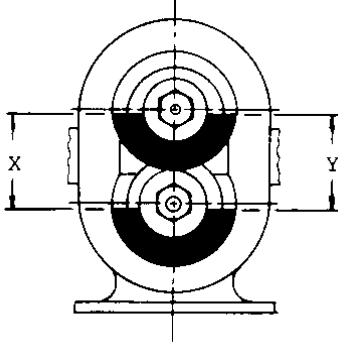

Procedure No. 2 - Install new gears

- Place faceplate group in vise and install keys as in Procedure No. 1.
- Slide gear on driven shaft, aligning keyway of gear with woodruff key on shaft.
- Position impellers as shown in the sketch in Procedure No. 1 with dimension X the same as dimension Y.
- Slide timing gear on drive shaft and align keyway in gear with woodruff key in shaft and mesh gears.
- Recheck dimension X and dimension Y to be certain that they are the same.
- Mark gears as indicated in Procedure No. 1.
- Slide gears off shafts and follow minor reassembly instructions.

Procedure No. 3 - Install new bushings

- Disassemble in accordance with minor disassembly instructions.
- Press worn bushing from impeller housing and gear case.
- Press new bushings in impeller housing.
- Press bronze bushings in gear case.
- Remove expansion plug in gear case cover.
- Press out worn bushings and press new bushings in gear case cover. Caution: If impeller housing bushing is steel backed Teflon, do not ream.
- Check gearcase lip seals and bearings for damage. Replace parts as necessary.

Reassemble In Accordance With Minor Reassembly Instructions:

- Apply grease to gasket seal surface on impeller housing. Then press gasket in place. Grease is used to hold gasket in position.
- Place packing glands in seal chambers in housing.
- After checking for burrs, insert shafts through housing bushing, packing glands and gear case bushings.
Note: Insert drive shaft in the same position as when disassembled.
- Tighten cap screws, which hold the faceplate in place.
- Install carbon steel gear keys in shaft keyways.
- Slip proper timing gear on driven shaft.
- Slip timing gear on the drive shaft, rotating shaft to align key with gear keyway, taking precautions that the timing marks are face out and aligned. There are two punch marks appearing on the gear on the drive shaft and one punch mark on the mating tooth on the driven shaft.
- Spin the pump drive shaft several times to be certain that there is no interference from incorrect timing.
- Apply grease to gasket seal surface on gear case. Press gasket in place. The same gasket is used on both impeller housing and gear case.

10. Slide gear case cover over shafts, being certain that drive shaft bore in cover is properly positioned in relation to drive shaft.
CAUTION: Take care in sliding lip of oil seal over drive shaft. If proper care is not taken, the lip will be damaged and oil leakage will result
11. Tighten six cap screws holding gear case cover in place.
12. Install new packing in seal chambers and tighten packing gland nuts to finger tightness. If pump is equipped with mechanical seals, install them according to the seal instructions.
13. Install the drainpipe plug.
14. Remove oil level plug and fill gear case with lube oil (see lube oil chart, page 9) to the oil level hole.
15. Install and tighten fill plug and oil level plug.
16. Spin the assembled pump several times to be certain that there is no interference from incorrect timing. If no interference is apparent, then the pump is ready to be put back in service.

Major Disassembly Instructions:

The first seven steps are the same as in the minor disassembly procedure. The major disassembly involves the disassembly of the faceplate group.

8. Place faceplate group in a vise.
CAUTION: Use soft vise jaws to prevent damage to gasket seal surface.
9. Remove packing gland nuts (32) and slide packing gland (30) out of the way. Then remove packing (29) from both seal chambers on faceplate. If pump is equipped with mechanical seals, refer to the seal instructions that were shipped with the pump.
10. Remove six bearing hex head bolts (12).
11. Remove the two bearing covers (14).
12. Remove the two faceplate bearing locknuts (15).
13. Slide impeller and shaft assembly out through the fluid chamber side of faceplate.
14. Remove the two ball bearings (17) from the bearing bridge on faceplate.
15. Check condition of lip seals (18) and replace if required.
16. Remove the two setscrews (11) from each impeller hub.
17. Press shafts through impellers by placing impeller and shaft assembly in press with threaded stub shaft up.
18. Remove woodruff impeller keys.

Reassembly:

1a. Install impellers onto shafts **[For non-galling impellers (ductile iron)]**

- i. Apply lubricant to shaft end on which impeller fits (White lead is recommended).
- ii. Slip impeller on shaft from the threaded stub shaft end.
- iii. Install stainless steel woodruff impeller key.
- iv. Align keyway in impeller with woodruff impeller key.
- v. Press impeller into proper position, and install setscrews as tight as possible. The dimensions shown below are given from the shoulder on the shaft to the nearest flat face on the hub of the impeller.

Pump Size	Impeller Location (inches)
30A	3.949 – 3.960
2A & 3A	4.709 – 4.720
70A & 120A	5.677 – 5.690
330	6.942 – 6.955

WARNING



WARNING

Wear heat-resistant gloves when handling hot components.

1b. Install impellers onto shafts **[For galling impellers (stainless steel)]**

- i. Impellers must be shrunk on the shafts, due to galling properties of the material.
 - ii. Heat impellers to 500-550°F for 1 ½ -2 hours.
 - iii. Quickly assemble shaft and impeller with keys in place into proper position according to the dimensions from above.
 - iv. Allow cooling.
2. Install lip seals (18) in faceplate (22), in bottom of bearing bores on bearing bridge.
 3. Install faceplate bearings (17) in bearing bores. Before installation, pack bearings with grease.
 4. Insert packing (29) and glands (30) in seal chambers on faceplate.
 5. Insert impeller and shaft assemblies, threaded portion first, through stuffing box, packing, gland and inner race of faceplate bearing. Secure assemblies in this position by tightening the faceplate bearing lock nuts (15).
 6. Insert bearing cover (14) in place and tighten bearing hex head bolts (12). The impeller and shaft assemblies are now secure in the faceplate.
 7. Check the clearance with a feeler gauge, between the machine face of the faceplate and the flat surface on the lobe of the impeller. This setting clearance will vary with the material of construction and pumping temperature. See chart below for the proper setting clearance. This clearance is checked by revolving the impeller and shaft 360°, while checking the clearance at multiple positions. All other clearances are automatically set if this clearance is correct.

See Next Page For Clearances

Chamber Clearances:

Faceplate gaskets compress to approximately .003 - .004 inches when pump bolts are tightened. For impeller assembly settings and resultant clearances, see below.

MODEL MATERIAL CLEARANCES		A IMPELLER SETTING (SIDE)		B RESULTING SIDE CLEARANCE (OPPOSITE SIDE)		C ON RADII		D RESULTING PASS OVER	
		MIN.	MAX.	MIN.	MAX.	MIN.	MAX.	MIN.	MAX.
Model: 30A									
Non-Gall	Standard	.0010	.0015	*	.0040	.0020	.0035	.0005	.0035
	Hot	.0030	.0035	.0035	.0080	.0050	.0065	.0015	.0045
Gall	Standard	.0035	.0040	.0040	.0085	.0050	.0065	.0025	.0055
	Hot	.0065	.0070	.0070	.0115	.0080	.0095	.0045	.0075
Models: 2A, 3A, 70A, 120A									
Non-Gall	Standard	.0020	.0025	.0025	.0080	.0040	.0060	.0005	.0045
	Hot	.0060	.0065	.0065	.0120	.0080	.0100	.0035	.0075
Gall	Standard	.0065	.0070	.0070	.0125	.0080	.0100	.0035	.0075
	Hot	.0105	.0115	.0105	.0165	.0120	.0140	.0060	.0110
Model: 330									
Non-Gall	Standard	.0040	.0045	.0045	.0100	.0060	.0080	.0015	.0065
	Hot	.0090	.0100	.0090	.0150	.0110	.0130	.0050	.0110
Gall	Standard	.0105	.0115	.0105	.0165	.0120	.0140	.0060	.0120
	Hot	.0155	.0165	.0155	.0215	.0170	.0190	.0100	.0160

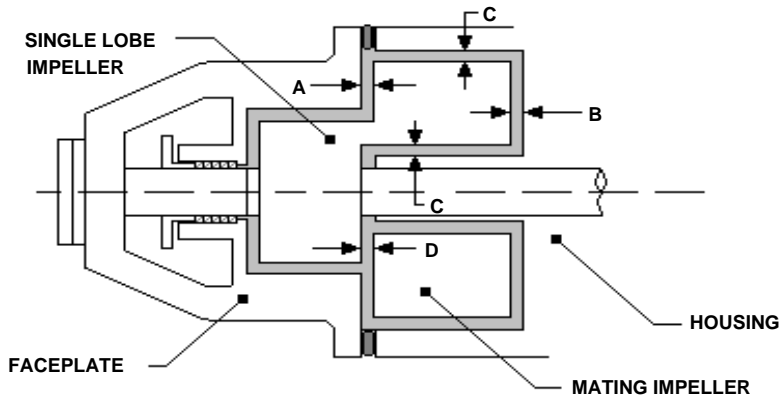

* Check to ensure that pump still rotates freely

8. If the impellers are properly set on the shaft to dimensions from step 1, then the initial setting clearance will always be too large. Thus, to move the impeller to the proper setting, add shims between bottom of bearing bore and the bearing outer race. The following shims are available:
 Red .002"
 Blue .005"
 Pink .015"
9. Grease faceplate bearings thru fittings on bearing caps.
10. For the remaining reassembly procedure, refer to steps 1 - 16 in Minor Reassembly Instructions.

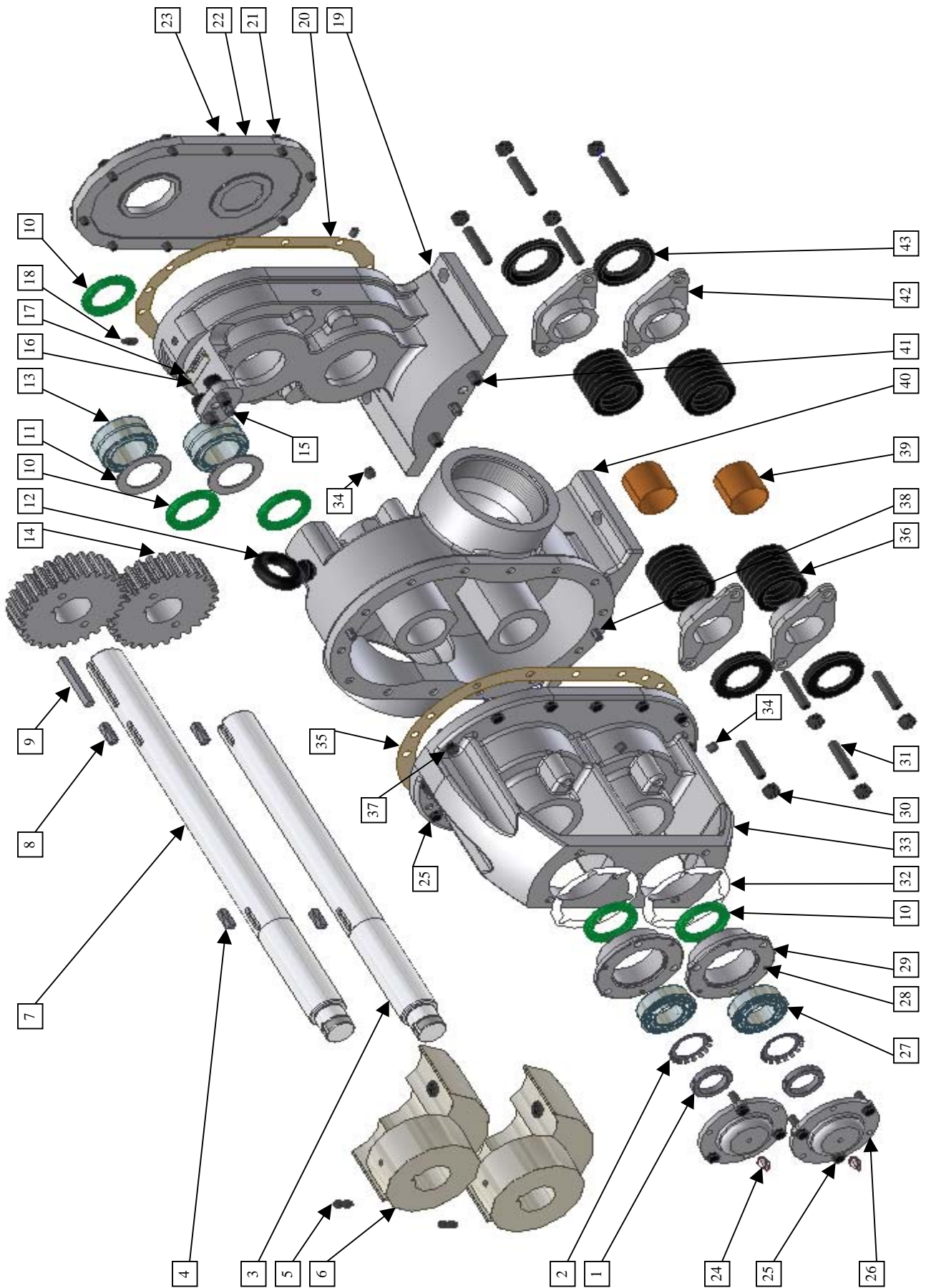

General Parts List For Model 600 Pumps

Item #	Description	Qty
1	Lock Nut	2
2	Lock Washer	2
3	Driven Shaft (CI)	1
	(SS)	
4	Impeller Key (CI)	2
	(SS)	
5	Set Screw	4
6	Impellers (CI) S.L.	2
	(CI) D.L.	
	(SS) S.L.	
	(SS) D.L.	
7	Drive Shaft (CI)	1
	(SS)	
8	Gear Key	2
9	Key	1
10	Lip Seal	5
11	Bearing Spacer	2
12	Eye Bolt	1
13	Roller Bearing	2
14	Timing Gear	2
15	Dowel Pin	2
16	Nametag	1
17	Drive Screw	2
18	Vented Pipe Plug	1
19	Gear Case	1
20	Gear Case Gasket	1
21	Hex Head Bolt	10
22	Gear Case Cover	1
23	Pipe Plug	2
24	Grease Fitting	2
25	Hex Head Bolt	16

Item #	Description	Qty
26	Bearing Cover	2
27	Ball Bearing	2
28	Set Screw	6
29	Bearing Carrier	2
30	Nut (CI)	8
	(SS)	
31	Stud	8
32	Shim -----.002"	As Req.
	.005"	As Req.
	.015"	As Req.
33	Faceplate (CI)	1
	(SS)	
34	Pipe Plug (CI)	8
	(SS)	
35	Housing Gasket	1
36	Packing	4 sets
37	Cap Screw	4
38	Dowel Pin	2
39	Housing Bushings	2
	(CI) DU Bushing	
	(SS) Carbon Bushing	
40	Impeller Housing (CI)	1
	(SS)	
41	Cap Screw	4
42	Packing Gland (CI)	4
	Split Glands for (SS)	8
43	V-Ring	4

Note:

- (CI) are Cast Iron pumps that will have corresponding steel and/or ductile iron components.
- (SS) are Stainless Steel pumps that will have corresponding stainless steel components.
- **Recommended spare parts are in bold text.**

When ordering spare parts please specify pump model, serial number, part number & part name.

WARNING



WARNING

Failure to follow these instructions could result in serious bodily injury or death.

Do not attempt to work on any Tuthill pump installation before completing the steps below.

Disconnect the drive so that it cannot be started while work is being performed.

Review the Material Safety Data Sheet (MSDS) applicable to the liquid being pumped to determine its characteristics and the precautions necessary to ensure safe handling.

Vent all pressure within the pump through the suction or discharge lines.

All Tuthill pumps contain residual hydraulic oil from the factory production test.

Determine if this is compatible with the fluid you are pumping. If the fluid is incompatible, then the pump must be fully flushed prior to use.

If the pump is to be operated at elevated temperatures, the pump should be brought up to operating temperatures gradually. Rapid or sudden introduction of liquids at elevated temperatures into the cold liquid chamber of the pump could cause damage to pump externals, seals or other internal parts.

Pumps can run dry provided provisions are made for the mechanical seal if one is used. Failure to comply with this could cause severe damage to the mechanical seal parts.

Pump needs to be earthed separately to avoid a buildup of electro-static charge.

Disassembly & Reassembly Instructions for Model 600 Pumps

Minor Disassembly For Fluid Chamber Inspection:

1. Remove all burrs on drive shaft with a mill file or emery paper. Also check for deposit of paint. Special care should be taken around the keyway and beveled corner on the drive shaft. These two areas are normally where burrs appear. Burrs or paint will cause an obstruction in the bushing area.
2. Drain oil from gear case by removing lower drainpipe plug. Remove cap screws (23) on face of gear case cover.
3. Remove gear case cover (22) by sliding over shafts.
4. **If the timing gears (14) are a slip fit on the shafts.** Mark gears so that in reassembly the gears may be remounted on the shafts from which they were removed. Remove the gears by loosening the setscrews. There are two in each gear. Then slide gears off drive end of shaft. If gear keys are sheared a gear puller may be required. Remove two woodruff gear keys (8).
5. **If interference fitted (IF) timing gears (14) are furnished.** Mark gears so that in reassembly the gears may be remounted on the shafts from which they were removed. IF gears do not have setscrews. First attempt to remove them can be made with a standard gear puller. Check that the gears have the correct timing marks before removal. If necessary, mark them again. If the gear puller was not successful in removing the gears, heat the gear OD with a torch and use a hydraulic jack to remove the gears.

WARNING



WARNING

Wear heat-resistant gloves when handling hot components.

6. Remove packing gland nuts (30) and slide packing gland (42) out of the way. Then remove packing (36) from both seal chambers on impeller housing. This step may not be necessary if there is not excessive shaft wear in the stuffing box. If pump is furnished with mechanical seals, follow the instructions of the seal manufacturer.
7. Remove hex head bolts (25) on outboard side of faceplate. Make note on which side the drive shaft is located for reassembly. Remove entire faceplate by sliding away from impeller housing. **CAUTION: Faceplate assembly will be heavy and not balanced. Use proper lifting methods.** This assembly includes the impellers and shafts installed in the faceplate. **CAUTION:** Do not disturb the bearing covers (26) on the bearing bridge on the faceplate. These covers hold the adjustment of clearance of the impeller in relation to the fluid chamber.

If further disassembly is required, refer to major disassembly instructions.

Fluid Chamber Check Points:

Procedure No. 1 - Check for twisted shaft

1. Place faceplate group upright in vise. Caution: Use soft jaws to prevent damage to the gasket seal surfaces. Tighten jaws on sides of bearing bridge.
2. Install carbon steel gear keys on an angle. Angle is to hold gears from sliding down on shaft.
3. Slide proper timing gear on drive shaft, revolving shaft to align key with gear keyway, taking precautions that the timing marks are face out and aligned. There are two punch marks appearing on the gear on the drive shaft and one punch mark on the mating tooth on the driven shaft.
4. Turn impellers to the position shown below. If the dimension X is the same as dimension Y, then there is no shaft damage. If there is a variation, then the shaft is twisted or the impeller keys may be sheared. Disassemble in accordance with major disassembly instructions. If the impeller keys are sheared, install new keys and recheck for twisted shaft.

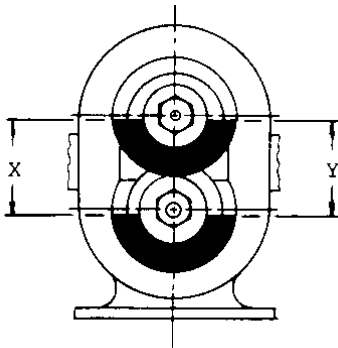

Procedure No. 2 - Install new gears

1. Place faceplate group in vise and install woodruff keys as in Procedure No. 1.
2. Slide gear on driven shaft, aligning keyway of gear with woodruff key on shaft.
3. Position impellers as shown in the sketch in Procedure No. 1 with dimension X the same as dimension Y.
4. Slide timing gear on drive shaft and align keyway in gear with woodruff key in shaft and mesh gears.
5. Recheck dimension X and dimension Y to be certain that they are the same.
6. Mark gears as indicated in Procedure No. 1.
7. Slide gears off shafts and follow minor reassembly instructions.

Procedure No. 3 - Install new bushings

1. Disassemble in accordance with minor disassembly instructions.
2. Press worn bushing from impeller housing and gear case.
3. Press new bushings in impeller housing.
4. Press bronze bushings in gear case.
5. Remove expansion plug in gear case cover.
6. Press out worn bushings and press new bushings in gear case cover. Caution: If impeller housing bushing is steel backed Teflon, do not ream.
7. Check gear case lip seals and bearings for damage. Replace parts as necessary.

Reassemble In Accordance With Minor Reassembly Instructions:

1. Apply grease to gasket seal surface on impeller housing. Then press impeller-housing gasket in place. Grease is used to hold gasket in position.
2. Place packing glands (42) in seal chambers of housing (40).
3. After checking for burrs, insert shafts, through housing bushing, packing glands and gear case bearings. **Note:** Insert drive shaft on same side as when disassembled.
4. Tighten cap screws, which hold faceplate in place.
5. **Slip fit timing gears.** Install carbon steel gear keys in shaft keyways. Slip proper timing gear on driven shaft. Then slip timing gear on drive shaft, revolving shaft to align woodruff key with gear keyway, taking precautions that the timing marks are face out and aligned. These marks are two center punch marks on the gear on the drive shaft and one center punch mark on the mating tooth cavity. Then turn pump drive shaft over several times to be certain that there is no interference from being out of time. Tighten setscrews on shaft. Then install locking setscrew.
6. **Interference fitted timing gears.** Make sure that gears are properly marked with the timing marks and that the bores and keyways are free of burrs. Repair as necessary. Heat the gears to 500°F-550°F in an oven for 40 minutes. Add keys to the drive and driven shafts.

WARNING



WARNING

Wear heat-resistant gloves when handling hot components.

7. Install the timing gear on the driven shaft first, making sure that the timing marks are facing outward. Assure that the driven gear has cooled before installing the drive gear. Match the timing gears and install the drive gear. Rotate the shafts after the gear cools to assure the correct timing of the impellers.
8. If timing is correct, apply grease to gasket seal surface on gear case. Press gear case gasket in place.
9. Slide gear case cover over shafts, being certain that drive shaft bore in cover is properly positioned in relation to drive shaft. Then tighten cap screws holding gear case cover in place. **CAUTION:** Take care in slipping lip of oil seal over drive shaft. If proper care is not taken, the lip will be damaged and oil leakage will result.
10. Install new packings in seal chambers, tighten packing gland nuts to finger tightness.
11. Install drainpipe plug. Remove oil level plug. Fill gear case with lube oil (see lube chart on page 9) until oil comes out oil level hole. Then install and tighten fill plug and oil level plug.
12. Spin the assembled pump several times to be certain that there is no interference from incorrect timing. If no interference is apparent, the pump is ready to be put back in service.

Major Disassembly Instructions:

The first seven steps are the same as in the minor disassembly procedure. The major disassembly involves the disassembly of the faceplate group.

8. Place faceplate group in a vise. **CAUTION:** Use soft vise jaws to prevent damage to gasket seal surface.
9. Remove packing gland nuts (30) and slide packing gland (42) out of the way. Then remove packing (36) from both seal chambers on faceplate.
10. Remove six hex head bolts (25). Remove bearing covers (26). Press tines of lock washers (2) out of grooves on lock nut (1). Remove lock nut.
11. Remove bearing carrier (29) and bearing (27). **CAUTION:** Note the shims that are placed between bearing carrier (29) and faceplate (33). If shafts and impellers are not replaced, these shims must be returned to the same position from which they were removed. Now slide impeller and shaft assembly out through the fluid chamber side of faceplate.
12. Remove the two double row faceplate ball bearings (27) from the bearing carriers (29). Then remove lip seals (10) and check condition. Replace if required.
13. If the shaft or impeller needs to be replaced, remove two set screws (5) from each impeller hub. Then press shafts through impellers by placing impeller and shaft assembly in press with threaded stub shaft up. Remove impeller keys (4).

Reassembly:

1a. Install impellers onto shafts **[For non-galling impellers (ductile iron)]**

- i. Apply lubricant to shaft end on which impeller fits (White lead is recommended).
- ii. Slip impeller on shaft from the threaded stub shaft end.
- iii. Install steel woodruff impeller key.
- iv. Align keyway in impeller with woodruff impeller key.
- v. Press impeller into proper position, and install setscrews as tight as possible. The dimensions shown below are given from the shoulder on the shaft to the nearest flat face on the hub of the impeller.

Pump Size	Impeller Location (inches)
600	8.018 – 8.033

WARNING



WARNING

Wear heat-resistant gloves when handling hot components.

1b. Install impellers onto shafts **[For galling impellers (stainless steel)]**

- i. Impellers must be shrunk on the shafts, due to galling properties of the material.
 - ii. Heat impellers to 500-550°F for 1 ½ -2 hours.
 - iii. Quickly assemble shaft and impeller with keys in place into proper position according to the dimensions from above.
 - iv. Allow cooling.
2. Install lip seals (10) in faceplate (23), in bottom of bearing bores on bearing bridge.
 3. Install faceplate bearings (27) in bearing bores. Before installation, pack bearings with grease.
 4. Insert packing (36) and glands (42) in seal chambers on faceplate.
 5. Insert impeller and shaft assemblies, threaded portion first, through stuffing box, packing, gland and inner race of faceplate bearing. Secure assemblies in this position by tightening the faceplate bearing lock nuts (1).
 6. Insert bearing covers (26) in place and tighten bearing hex head bolts (25). The impeller and shaft assemblies are now secure in the faceplate.

7. Check the clearance with a feeler gauge, between the machine face of the faceplate and the flat surface on the lobe of the impeller. This setting clearance will vary with the material of construction and pumping temperature. See chart below for the proper setting clearance. This clearance is checked by revolving the impeller and shaft 360° while checking the clearance at multiple positions. All other clearances are automatically set if this clearance is correct.

See Next Page For Clearances

Chamber Clearances:

Faceplate gaskets compressed to approximately .003 - .004 inches when pump bolts are tightened. Impeller assembly settings and resultant clearances see below.

MODEL MATERIAL CLEARANCES		A IMPELLER SETTING (SIDE)		B RESULTING SIDE CLEARANCE (OPPOSITE SIDE)		C ON RADII		D RESULTING PASS OVER	
		MIN.	MAX.	MIN.	MAX.	MIN.	MAX.	MIN.	MAX.
Model: 600									
Non-Gall	Standard	.0060	.0065	.0065	.0120	.0080	.0100	.0035	.0085
	Hot	.0120	.0130	.0120	.0180	.0140	.0160	.0070	.0130
Gall	Standard	.0185	.0195	.0185	.0245	.0200	.0220	.0130	.0190
	Hot	.0245	.0255	.0245	.0305	.0260	.0280	.0170	.0230

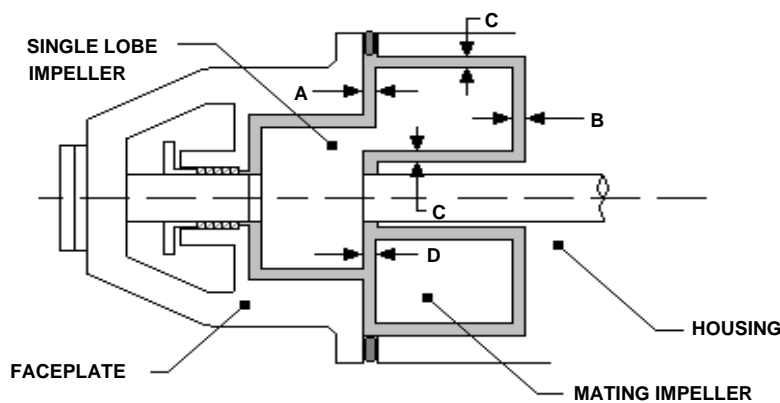

* Check to ensure that pump still rotates freely

8. If the impellers are properly set on the shaft to dimensions from step 1, then the initial setting clearance will always be too large. Thus, to move the impeller to the proper setting, add shims between bottom of bearing bore and the bearing outer race. The following shims are available:
 Red .002"
 Blue .005"
 Pink .015"
9. Grease faceplate bearings thru fittings on bearing caps.
10. For the remaining reassembly procedure, refer to steps 1 - 16 in Minor Reassembly Instructions.

Packings:

Installing Packings in Pumps:

1. Remove all old packing using a packing hook. Clean stuffing box and shaft thoroughly and examine shaft for wear or scoring. Check bearings for wear as this can cause an eccentric shaft rotation resulting in excessive leakage. Packings will not act as a bearing. If shaft surface is worn, replace shaft or have seal surface area resurfaced.

2. Be certain the proper size packing is used. The following packing sizes will apply:

<u>Pump Model</u>	<u>Packing Size</u>	<u>Shaft Diameter</u>	<u>No. of Rings</u>
30A	1/4" Square	1"	4
2A & 3A	1/4" Square	1-3/8"	4
70A & 120A	7/16" Square	1-7/8"	6
330	1/2" Square	2-1/4"	6
600	1/2" Square	2-1/2"	6

- Always cut packings into separate rings. Never coil around shaft. (standard factory packings are pre-cut and pre-formed) If bulk packing is used cut each ring on a mandrel the same size as the pump shaft. Try rings in stuffing box to be certain that each ring fills the seal chamber and that there is no gap between packing joints.
- Install one ring at a time, seating each ring independently. Use clean oil to lubricate shaft and inside of stuffing box. Joints should be staggered and kept at least 90° apart. Each individual ring should be firmly seated with a tamping tool. Never depend entirely on the gland to seat a set of packings. This practice will jam the last rings installed but leave the front rings loose. The result is excessive and rapid wear.
- After last ring is installed, tighten gland nuts finger tight. Then start pump and take up nuts until leakage is decreased. Stopping leakage at this point will cause packing to burn. If temperature rises in seal area, back off on packing nuts as this indicates excessive gland pressure.
- Allow packing to leak freely for at least one hour when starting up a newly packed pump. Take up gland nuts gradually, 1/16 turn every 5-10 minutes, until leakage stabilizes at about 3-5 drops per minute. If temperature in seal area increases, back off and start over.

Note:

- Replace packing when leakage cannot be controlled by further take-up of gland.
- Test results indicate that 70% of the wear occurs on the first two rings of packing nearest the gland. Rings next to the gland work the hardest. The rings in the bottom of the stuffing box serve to throttle some fluid pressure. On abrasive service the bottom ring takes most of the beating. Therefore, this ring should be a firm ring.

How to Pack for Abrasive Liquids:

As used here "Abrasives" is a broad term intended to cover the problem of packing against slurries, congealing liquids and the likes. They cause the greatest damage to equipment, and present difficulties for packing. In general, this involves flush, purges and temperature control. Hard facing on the shaft seal surfaces, such as stellite or ceramic, are also recommended.

When pumping slurries and abrasives an external source of clear or otherwise suitable liquid must be force fed at a pressure higher than that existing in the stuffing box. This differential pressure is in the area of 10-25 psi.

Suspended Solids:

Solids which are suspended in liquids and which are an inherent part of their structure would include starch, clay slurry, muddy water and other similar slurries. This is best handled by an external flush of clear liquid through a lantern ring as shown. This arrangement will result in a small amount of product dilution and is controlled by the differential pressure in the seal chamber.

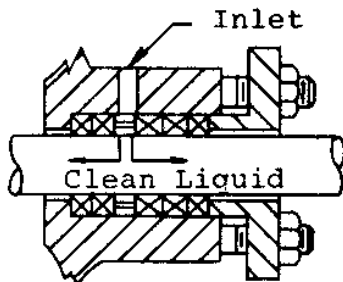

Packing with Internal Flush

How To Pack For Congealing Liquids:

These liquids congeal either because of a change in temperature or as a result of drying out after exposure to air. Clay coatings and latex fall into both categories. A good rule is to keep the fluid moving before congealing can take place. Control with cooling or heat and/or by flush or purge.

Some products harden to a solid state when exposed to air. Clay coatings, latex and sugars are examples. An effective flush is shown. Note that this type of flush does not enter the product, but only mixes with the product leakage. This arrangement also tends to serve as cooling medium for the seal chamber.

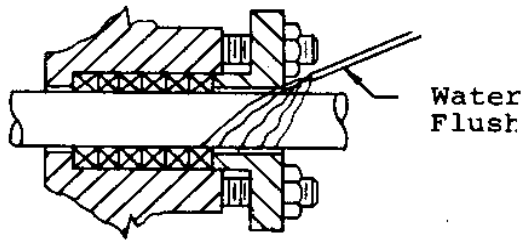

Packing with External Flush

Torque For Shaft Locknuts













Industrial Models

30A
2A & 3A
70A, 120A, 330, & 600

Torque (ft-lbs.)

60 – 65
75 – 80
120 – 125

Torque For Faceplate Bolts

<u>Pump Model</u>	<u>Screw Description</u>	<u>Type of Metal</u>	<u>Faceplate Qty. & Appearance</u>	<u>Applied Torque (ft-lbs)</u>
600	½" Hex Head, 1 ½" LG. P104-1H	Note 1	10 -- 	70 - 75
	½" Socket Head, 1 ½" LG. P105-74	Note 2	4 -- 	70 - 75
	1/2" Socket Head, 11/8" LG P104-1S4	Note 3	14-- 	30 - 35
330	½" Hex Head, 1 ¼ " LG. P104-4H	Note 1	8 -- 	70 - 75
	½" Socket Head, 1 ¼ " LG. P105-57	Note 2	4 -- 	70 - 75
70A, 120A	½" Hex Head, 1 ¼" LG. P104-4H	Note 1	13 -- 	70 - 75
	½" Hex Head, 1" LG. P104-2H	Note 1	1 -- 	70 - 75
	¼" Socket Head, 1 ½" LG. P105-78	Note 2	4 -- 	11 - 14
2A, 3A	½" Hex Head, 1" LG. P104-2H	Note 1	4 -- 	70 - 75
	½" Hex Head, 4" LG. P104-15H	Note 1	2 -- 	70 - 75
30A	3/8" Socket Head, 1" LG. P105-66	Note 2	4 -- 	45 - 50
	3/8" Socket Head, 3 ½" LG. P105-79	Note 2	2 -- 	45 - 50

1. SAE grade 5 steel (Min. tensile strength of 105,000 PSI heat-treated medium carbon).
2. High carbon alloy, quenched and tempered (Min. tensile strength of 160,000 PSI).
3. Grade 316 stainless steel.

Serial Number Location

The serial number will be located on the pump nameplate. In addition, the serial number may be located on the impeller housing top port. Please furnish this number when ordering parts. Pumps with the built-in pressure relief valve must have a top suction port.

Common Causes of Pump Problems

Symptoms								Possible Causes	Suggested Solutions
Excessive Gland Leakage	Noisy	Excessive Heat	Wear	Starts, Then Loses Prime	Fails to Pump	Low Flow	Takes Too Much Power		
	✓			✓		✓		Suction lift high for vapor pressure of liquid	Reduce vacuum requirements
	✓		✓			✓		Liquid too viscous for pump speed	Reduce pump speed
	✓			✓		✓		Air leakage in suction piping	Tighten and seal all joints
				✓	✓			Suction pipe not immersed in liquid	Lengthen suction pipe or add liquid to supply tank
	✓				✓			Suction strainer clogged or of insufficient area	Clean strainer or use larger size
✓	✓	✓	✓				✓	Misalignment between pump and driver	Re-align. Check coupling alignment with dial indicator
	✓	✓	✓				✓	Rotating elements binding	Disassemble and inspect
	✓	✓	✓				✓	Pipe strain on pump casing	Disassemble pipe and re-align before reassembling
	✓					✓		Relief valve chattering	Check setting and valve seating
✓			✓			✓	✓	Excessive system pressure	Check for obstructions in discharge line.
✓		✓					✓	Stuffing box packed too tightly	Repack and adjust
						✓		Pump speed too low	Check pump impeller speed
✓						✓		Pump parts worn	Have pump reconditioned or replace worn parts
						✓	✓	Obstruction in discharge line	Check discharge piping and valves for obstruction
					✓			Wrong direction of rotation	Reverse motor
	✓					✓		Suction line sized too small	Increase suction piping size
						✓		Torque control coupling not adjusted	Readjust coupling

Troubleshooting

1. Problem: No fluid is delivered.

- a. Power is not on.
- b. Net positive suction head available (NPSHa) is lower than required for the vapor pressure of the liquid pumped. You should calculate NPSHa and redesign piping, if necessary.
- c. There are leaks in suction line.
- d. Direction of shaft rotation is incorrect.
- e. Relief valve setting is too low (if the pump is equipped with a relief valve). Liquid is discharging through the by-pass port.

2. Problem: Capacity is too low.

- a. There are air leaks in suction line.
- b. Suction losses are too high. The suction lift is too great or the suction line is too small or too long. This can be detected by installing a vacuum gauge directly at the pump suction. The maximum vacuum at the pump suction should never exceed 15" of mercury. Vaporization caused by higher vacuums will generally result in capacity drop-off. Redesign suction conditions.
- c. Pump speed is too slow.
- d. Strainer is too small or obstructed.
- e. Suction pipe or port is not immersed in liquid deep enough.
- f. Piping is improperly installed permitting an air pocket to form in the pump.
- g. Increased clearances or wear in the pump will sometimes cause the pump to deliver an insufficient supply of liquid.

3. Problem: Pump works spasmodically.

- a. Leaky suction lines.
- b. Suction conditions vary.
- c. Air or vapor is in the liquid.

4. Problem: Excessive power draw.

- a. Pressure is too high.
- b. Liquid is more viscous than originally expected.
- c. Suction or discharge line is obstructed.
- d. There is insufficient horsepower.
- e. There are mechanical defects:
 - i. Drive shaft and pump are misaligned.
 - ii. Pump is binding due to incorrect clearance setting.
 - iii. Pump shaft is bent.
 - iv. There is misalignment within pump due to bad piping or poor installation, causing strain or distortion.

5. Problem: Pump is noisy.

- a. Pump is cavitating due to inadequate suction conditions.
- b. There is misalignment of coupling.
- c. Coupling is set too close to pump.
- d. There is vibration of the pump due to a worn or bent shaft.
- e. There are air leaks on suction side of pump or air entrainment in the fluid.

6. Problem: Pump leaks.

- a. Bolts need tightening, allowing gaskets or o-rings to leak.
- b. Gaskets or o-rings are damaged.

Note: Packings are designed to leak. Leakage should be at a rate that will prevent excessive heating on the bracket at the packing area.

Material Returns

If it becomes necessary to return a pump to the factory, a Return Goods Authorization (RGA) must be obtained from either your local Authorized Distributor or our Alsip plant. No RGA can be issued until a completed Material Safety Data Sheet (MSDS) has been forwarded to our Alsip plant and return of the pump has been approved.

- Tuthill pumps are precision-built and must be handled with care.
- Pumps must be drained of all fluid and the ports plugged to prevent foreign material from getting into the pump.
- Pumps must be packaged securely to prevent damage while in transit.

WARRANTY

Tuthill Pump Group warrants its products against defective material and workmanship for 90 days from the date of startup or one year from date of shipment from Tuthill's plant, whichever comes first. This warranty does not include products damaged by tampering, improper installation, abuse, or wear. Nor does it cover consequential damages, or other losses due to pump failure.

Because of the unpredictable nature of fluids encountered, pumps are not warranted for any specific life.

Contact Information

If additional information is required to facilitate operation or maintenance, contact the authorized Tuthill distributor shown below. Information on Tuthill contacts can also be obtained at www.tuthillpump.com.

European Contact Info:

Tuthill Pump Group
Manners Industrial Estate
Ilkeston, Derbyshire DE7 8YA
England
tuthilluk@tuthill.com

North America Contact Info:

Tuthill Pump Group
12500 South Pulaski Road
Alsip, Illinois 60803
U.S.A.
www.tuthillpump.com